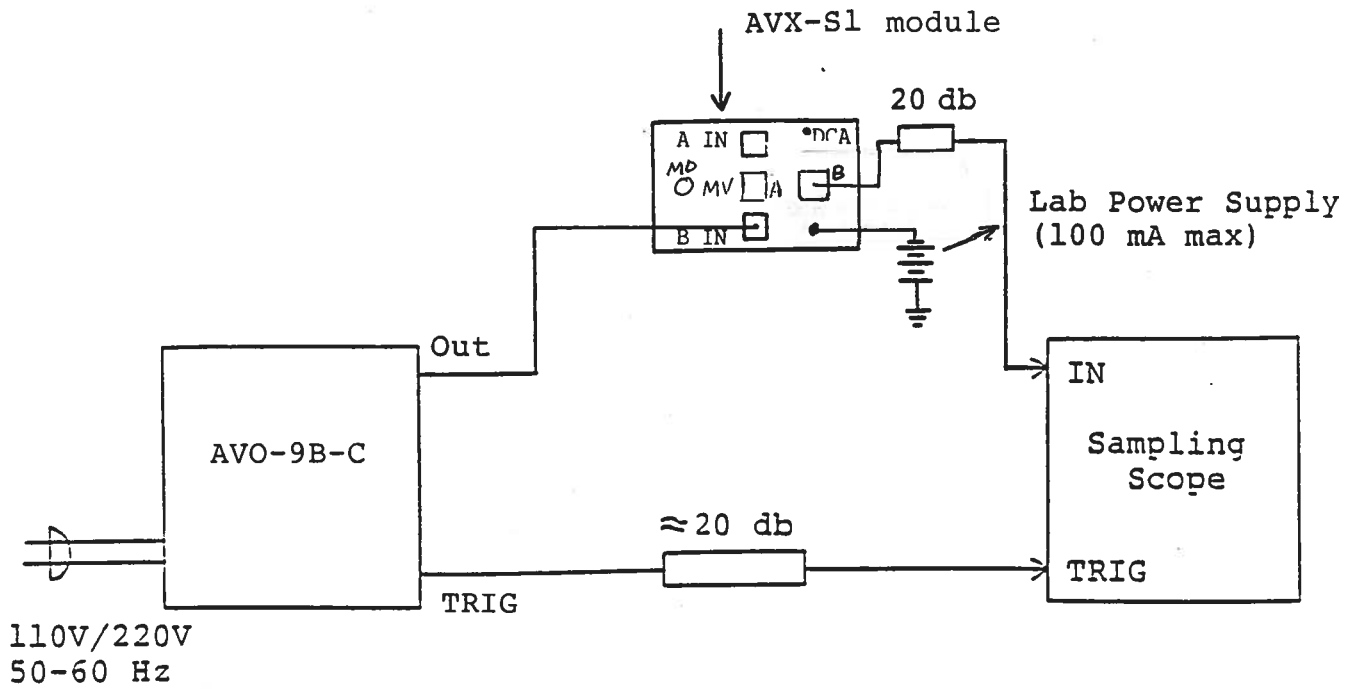

Fig. 2

PULSE GENERATOR TEST ARRANGEMENT

(AVX-S1 MODULE CONNECTED)



- 1) A general description of the AVX-S1 module is given in the enclosed data sheet.
- 2) The AVX-S1 module should be connected to the AVO-9B-C mainframe via the supplied 24" RG174 cable. The input voltage applied to the series diode-40 Ohm circuit may be monitored by connecting the MV output port to the sampling scope via a 20 db attenuator. The output amplitude (V_{MV} , volts) and input pulse voltage amplitude (V_{IN}) are related as follows:

$$V_{IN} = 100 V_{MV}$$

The diode current may be estimated as follows:

$$I_D = \frac{V_{IN} - 2.0}{40}$$

- 3) The laser diode plugs directly into the socket on the side of the AVX-S1 module.

CAUTION: A four PIN package can be inserted improperly so it is necessary to check the PIN matings using the drawings on the following page.

- 4) A forward DC bias may be applied to the laser diode by connecting a DC potential of 0 to +5 Volts to the DC solder terminal. The application of a small forward bias often yields a more ideal diode current waveform. Note that the DC port must be shorted to ground if a bias is not applied.
- 5) The input pulse and the DC bias should be switched to the A or B inputs as required to operate the A or B laser diode.

PR-51

(SN 6706) JULY 9
(SN 6706 MOD ~~SEPT~~ 93)

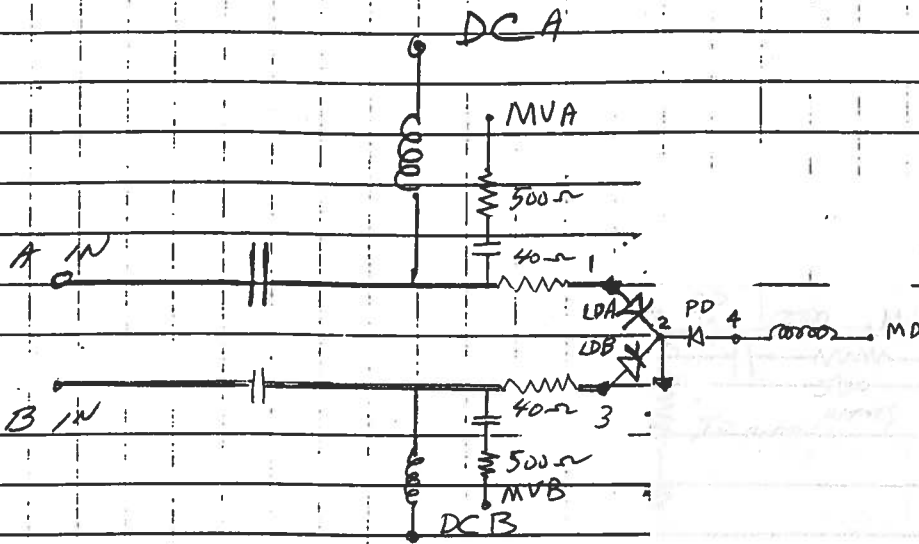

FUNCTIONAL EQUIV. Ckt.

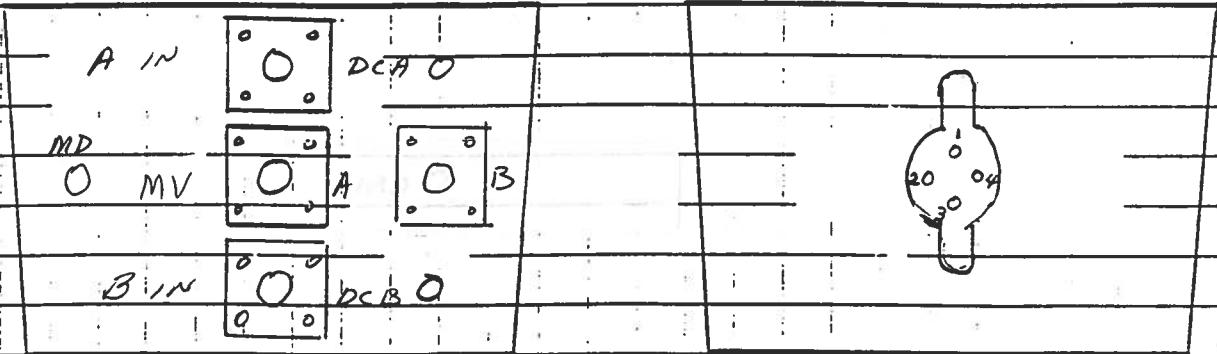

PACKAGE

Sept. 9/93

for Xerox, SN 6706

AVX-SI-MI-XXA

DATE	DESCRIPTION	AMOUNT	BALANCE
