



AVTECH ELECTROSYSTEMS LTD.

NANOSECOND WAVEFORM ELECTRONICS
SINCE 1975

P.O. BOX 265
OGDENSBURG, NY
U.S.A. 13669-0265
TEL: (315) 472-5270
FAX: (613) 226-2802

TEL: 1-800-265-6681
FAX: 1-800-561-1970

e-mail: info@avtechpulse.com
<http://www.avtechpulse.com>

P.O. BOX 5120 STN. F
OTTAWA, ONTARIO
CANADA K2C 3H4
TEL: (613) 226-5772
FAX: (613) 226-2802

INSTRUCTIONS

MODEL AVX-S2-JHUA BIAS INSERTION UNIT

S.N.:

WARRANTY

Avtech Electrosystems Ltd. warrants products of its manufacture to be free from defects in material and workmanship under conditions of normal use. If, within one year after delivery to the original owner, and after prepaid return by the original owner, this Avtech product is found to be defective, Avtech shall at its option repair or replace said defective item. This warranty does not apply to units which have been disassembled, modified or subjected to conditions exceeding the applicable specifications or ratings. This warranty is the extent of the obligation assumed by Avtech with respect to this product and no other warranty or guarantee is either expressed or implied.

TECHNICAL SUPPORT

Phone: 613-226-5772 or 1-800-265-6681

Fax: 613-226-2802 or 1-800-561-1970

E-mail: info@avtechpulse.com

World Wide Web: <http://www.avtechpulse.com>

PULSE GENERATOR TEST ARRANGEMENT

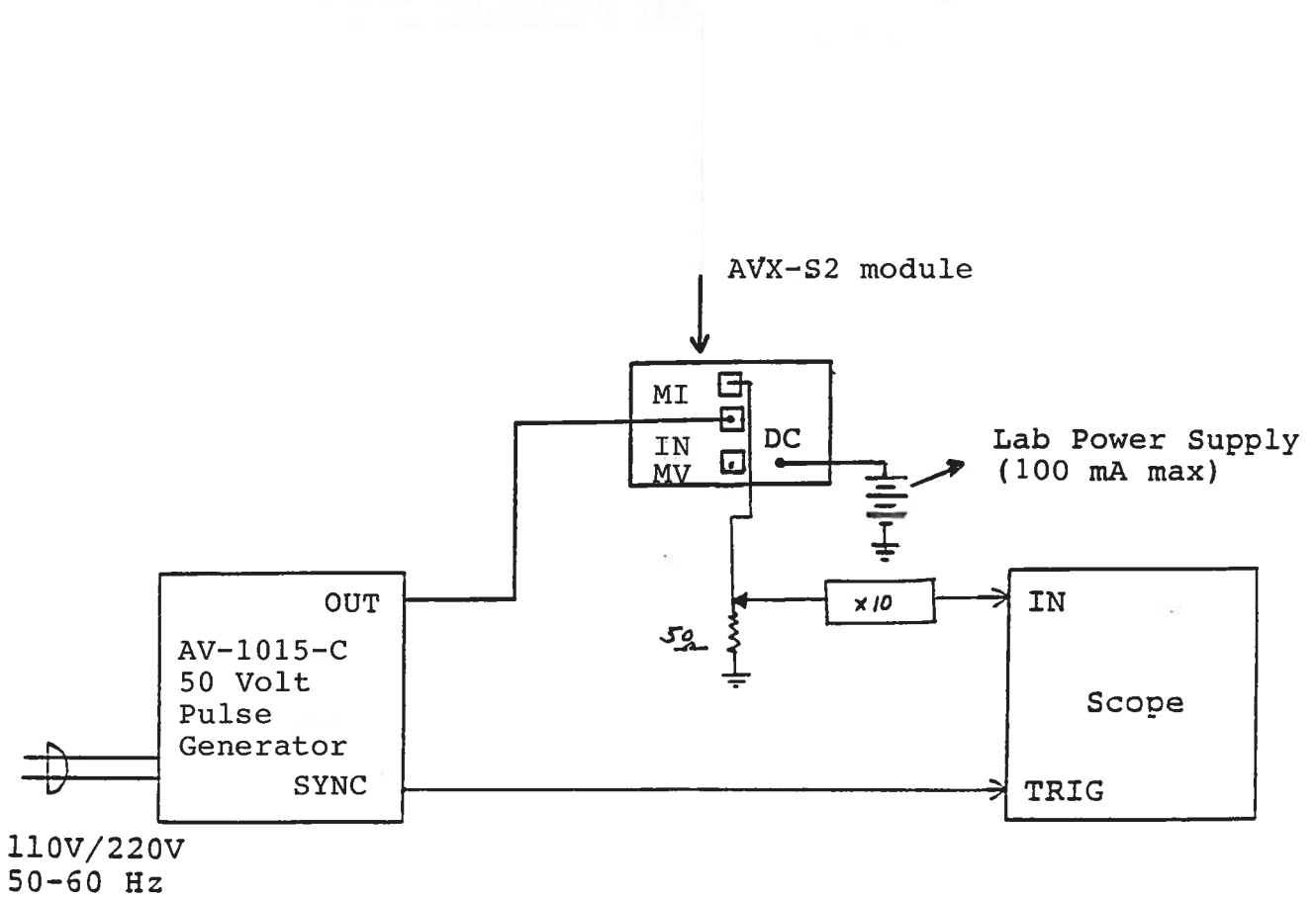

GENERAL INSTRUCTIONS

- (1) The AVX-S2 module should be connected to the pulse source mainframe via the supplied 24" RG174 cable. To obtain a peak pulse diode current of 1 Amp, the pulse source must be capable of supplying at least +53 Volts.
- (2) Gently insert the High Heat Load (P2) package into the 9 pin socket assembly.
- (3) Connect the MI port to a scope set to 5 Volt/div and with a 50 Ohm load impedance.
- (4) The PINS on the D connector (AMP No. 57-60140) correspond to the PINS on the P2 package with the exception that PINS 4 (Anode) and 7 (Cathode) are not connected.
- (5) Connect a positive current source to the DC terminal. A lab power supply operating in the current limiting mode is recommended. The source must have a compliance voltage of at least +5 Volts. Slowly increase the offset current to +100 mA (as indicated by the meter on the lab power supply). To avoid transients when connecting the lab power supply, the voltage control knob should be fully CCW and the prime power should be ON. Slowly and cautiously increase the voltage and monitor the current control knob (and ammeter) to insure that the offset does not exceed 100 mA. Final control should be via the current knob. Note that if a DC bias is not applied, the DC in terminal must then be shorted to ground.
- (6) The diode pulse current (Amps) and the Voltage at M_1 (Volts) are related as follows:
$$I_D = 0.2 V_{M_1}$$
- (7) For duty cycles exceeding 10%, the chassis should be attached to a heat sink capable of dissipating at least 10 Watts. The P2 package should be bolted to the copper platform for cooling. The copper platform may be removed for modifications (etc.) by removing the two Phillips screws which attach it to the chassis.
- (8) When modulating the diode using a sinusoidal source, it is critically important that the peak to peak RF current not exceed x2 the DC bias current (and the DC bias current must not exceed 100 mA). To a first approximation, the peak to peak input voltage should not exceed 10 Volts (with 100 mA DC applied).

(9) For additional information:

Tel: (613) 226-5772

Fax: (613) 226-2802



AVTECH ELECTROSYSTEMS LTD.

NANOSECOND WAVEFORM ELECTRONICS
SINCE 1975

P.O. BOX 265
OGDENSBURG, NY
U.S.A. 13669-0265
TEL: (315) 472-5270
FAX: (613) 226-2802

TEL: 1-800-265-6681
FAX: 1-800-561-1970
U.S.A. & CANADA

e-mail: info@avtechpulse.com

☒ BOX 5120 STN. F
OTTAWA, ONTARIO
CANADA K2C 3H4
TEL: (613) 226-5772
FAX: (613) 226-2802

Fax Ref No: 1853 From: Avtech Electrosystems Ltd.
To: The Johns Hopkins Our Fax No: (613) 226-2802
University Date: September 2, 1997
Attn: Raul Fainchtein Receivers Fax No: 301-953-6904
Tel: 301-953-6295
Subject: Quotation No. of pages: 3

Following our telephone conversation of September 2nd, I am pleased to provide the following revised price and delivery quotation:

Model designation: AVX-S2-JHUA.
Diode package: Applied optronics high heat load fibre coupled package (AOC-250-HHL100). Diode pins mate to socket assembly when package mounted on package platform.
D connector: Provides access to pins 1, 3, 5, 6, 8, 9 and 10.
Other: See standard AVX-S2.
Price: Quantity of 1: \$998.00 US each.
Quantity of 2: \$774.00 US each.
Note that these prices include our standard 5% academic discount and are FOB destination.
Delivery: 3 weeks ARO.

.../2

Thank you for your continuing interest in our products.
Please call me again (1-800-265-6681) if you require any
additional information.

Regards,

A handwritten signature in black ink, appearing to read 'Walter Chudobiak', written in a cursive style.

Dr. Walter Chudobiak
Chief Engineer

WC:my

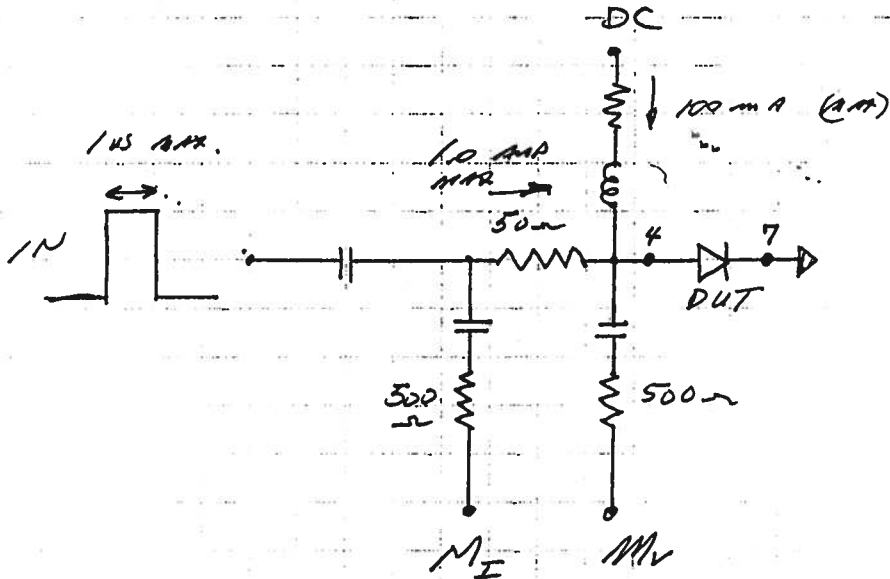

FUNCTIONAL EQUIVALENT CIRCUIT

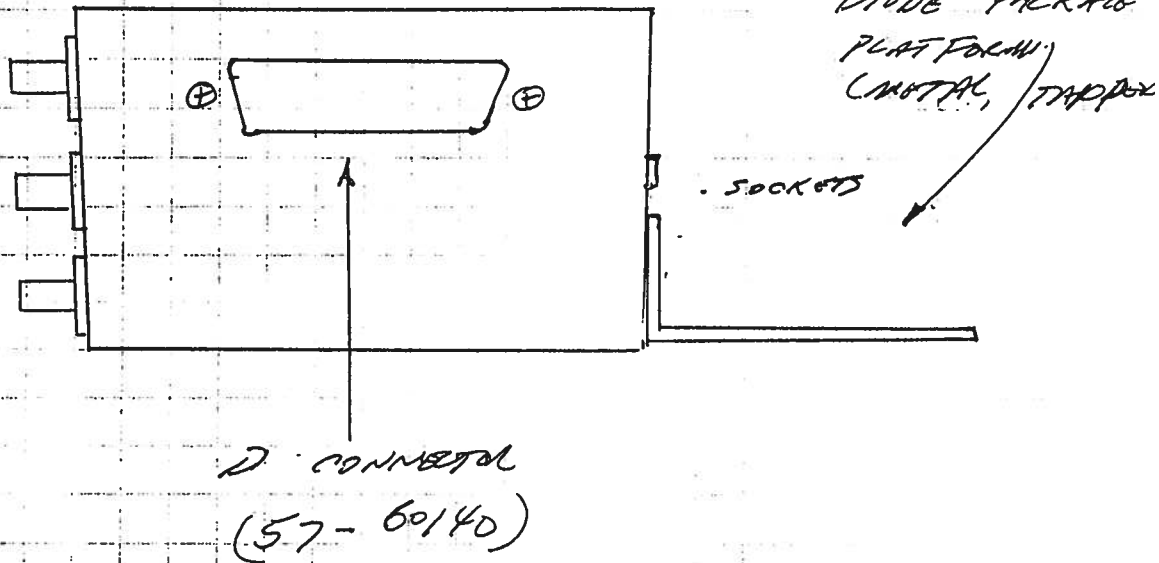
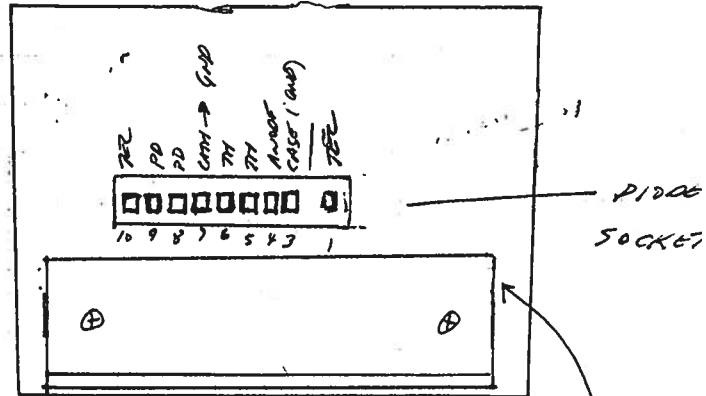
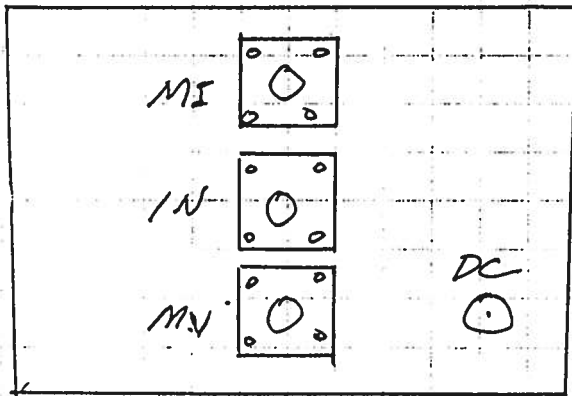

October 111991

Edition A

Disk: ANX-S

File: S2JHUA.INS