

Rise	Fall	Width	Measurements	Main Size
2.28821 ns	2.27875 ns	6.08750 ns		5ns/div Main Pos 51.6ns

AVRK-3-B-P, 550V amplitude, 6 ns pulse width

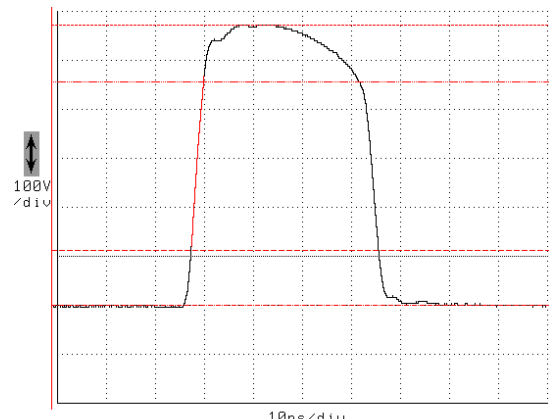

Rise	Fall	Width	Measurements	Distal
2.55324 ns	4.06250 ns	35.7818 ns		80% Proximal 20%

AVRK-3-B-P, 550V amplitude, 35 ns pulse width

The AVRK series offers high-voltage outputs (to 750 Volts) with fast rise times, and pulse widths of up to 100 ns. All models operate at pulse repetition frequencies (PRF) of up to 1 kHz.

The AVRK-1-B model provides amplitudes of up to 300V, with a rise time of 3 ns or less. The fall time varies with the pulse width and amplitude. The pulse width is adjustable from 5 to 100 ns.

The AVRK-2-B is similar, except that the maximum amplitude is increased to 400V, and the pulse width range is reduced to 7 to 65 ns.

The AVRK-3-B model provides amplitudes of up to 550V, with 4 ns rise times. The pulse width is adjustable from 6 to 35 ns.

The AVRK-4-B model provides amplitudes of up to 750V, with 4 ns rise times. The FWHM pulse width is adjustable from 6 to 20 ns.

The rise times can be reduced to < 2 ns with the addition of the -TR option.

The minimum useful operating amplitude is < 20% of the specified maximum on standard units. This can be reduced to < 4% by adding an internally-switched high-power attenuator (the -LVA option).

All models include a complete computer control interface (see <http://www.avtechpulse.com/gpib> for details). This provides GPIB and RS-232 computer-control, as well as front panel keypad and adjust knob control of the output pulse parameters. A large back-lit LCD displays the output

amplitude, polarity, frequency, pulse width or duty cycle as appropriate, and delay. To allow easy integration into automated test systems, the programming command set is based on the SCPI standard, and LabView drivers are available for free download at <http://www.avtechpulse.com/labview>.

A standard rear-panel Ethernet connector allows the instrument to be remotely controlled using the VXI-11.3, ssh, telnet, and web protocols. In particular, the VXI-11.3 features allows software like LabView to control an instrument using standard VISA communications drivers and network cabling, instead of using older-style GPIB cabling and GPIB controller cards. For details, please see <http://www.avtechpulse.com/options/vxi>.

A manual push button is provided for one-shot operation. A delay control and a sync output are provided for scope triggering purposes.

Either output polarity can be provided. A dual-polarity option is also available, which allows the polarity to be switched from the front panel, or by computer command.

A DC offset or bias insertion option is available with most units. Units with this option include a circuit similar to Model AVX-T at the output. The required DC offset or bias is applied directly to rear-panel solder terminals.

All models require 100-240 Volts, 50-60 Hz.

Contact Avtech ([info@avtechpulse.com](mailto:info@avtechpulse.com)) with your special requirement! Many units can be customized for particular applications.



AVRK-3-B



## SPECIFICATIONS

## AVRK SERIES

Model:	AVRK-1-B <sup>1</sup>	AVRK-2-B <sup>1</sup>	AVRK-3-B <sup>1</sup>	AVRK-4-B <sup>1</sup>
Maximum amplitude <sup>6</sup> : (50Ω load required)	300 V	400 V	550 V	750 V
Usable amplitude range, standard units:	Range 1: < 20% to 100% of the maximum specified amplitude			
Usable amplitude range, with -LVA option:	Range 1: < 20% to 100% of the maximum specified amplitude Range 2: < 4% to 20% of the maximum specified amplitude (The ranges are automatically selected based on the amplitude setting. The threshold percentages are approximate.)			
Pulse width (FWHM):	5 – 100 ns	7 – 65 ns	6 – 35 ns	6 – 20 ns
Rise time (20%-80%):	Standard: ≤ 3 ns With -TR option: ≤ 2 ns		Standard: ≤ 4 ns With -TR option: ≤ 2 ns	
Fall time (80%-20%):	<i>Varies with amplitude and pulse width<sup>7</sup>:</i>			
<i>Min PW, Min of ampl range:</i>	≤ 6 ns	≤ 6 ns	≤ 6 ns	≤ 6 ns
<i>Min PW, Max of ampl range:</i>	≤ 4 ns	≤ 4 ns	≤ 4 ns	≤ 4 ns
<i>Max PW, Min of ampl range:</i>	≤ 40 ns	≤ 25 ns	≤ 15 ns	≤ 10 ns
<i>Max PW, Max of ampl range:</i>	≤ 15 ns	≤ 15 ns	≤ 7 ns	≤ 6 ns
PRF:	1 Hz to 1 kHz			
Required load impedance:	50 Ohms <sup>5</sup>			
Output impedance <sup>3</sup> :	Low (much less than 50 Ohms)			
Polarity <sup>2</sup> :	Positive or negative or both (specify)			
Propagation delay:	≤ 150 ns (Ext trig in to pulse out)			
Jitter:	± 100 ps ± 0.03% of sync delay (Ext trig in to pulse out)			
DC offset:	-OS option <sup>4</sup> : Apply required DC offset (± 50 Volts, 250 mA DC max) to rear-panel solder terminals			
Standard trigger modes:	Internal trigger, external trigger (TTL level pulse, > 10 ns, 1 kΩ input impedance), front-panel "Single Pulse" pushbutton, or single pulse trigger via computer command.			
Double-trigger mode:	Optional <sup>8</sup> . Adds the ability to generate pulse doublets, instead of single pulses. The first and second pulses in the doublet have independently variable amplitude and pulse width. Both must have the same polarity. The second pulse will be delayed relative to the first by a minimum of 150 ns, and a maximum of 1 second (not to exceed 50% of the period). This delay is adjustable in the "Single External Trigger" and "Single External Trigger" modes. The delay is determined by the trigger signals in the "Double External Trigger mode". See the sample waveforms on the next page.			
Variable delay:	0 to 1.0 seconds (sync out to main out), for all trigger modes (including external trigger).			
Sync output:	> +3 Volts, > 50 ns, will drive 50 Ohm loads			
Gate input:	Synchronous or asynchronous, active high or low, switchable. Suppresses triggering when active.			
Monitor output:	Included. Provides a 20 dB attenuated coincident replica of the main output. Requires a 50 Ohm load, if used.			
Safety interlock option <sup>9</sup> :	This option adds a safety lock circuit on a rear-panel BNC connector. The signal pin of this safety lock BNC connector must be shorted to chassis ground by the user's circuitry (the short must be capable of carrying 5 mA of current from an internal +5V/1kΩ DC source), otherwise the output will be switched off automatically. The connector shield is connected to chassis ground.			
Connectors:	BNC			
GPIB & RS-232 control <sup>1</sup> :	Standard on -B units.			
Ethernet port, for remote control using VXI-11.3, ssh, telnet, & web:	Included. Recommended as a modern alternative to GPIB / RS-232. See <a href="http://www.avtechpulse.com/options/vxi">http://www.avtechpulse.com/options/vxi</a> for details.			
Settings resolution:	The resolution of the timing parameters (pulse width, delay, period) varies, but is always better than 0.15% of ( set value  + 20 ns). The amplitude resolution is < 0.1% of the maximum amplitude.			
Settings accuracy:	Not specified. The pulse width setting experiences some thermal drift and interaction with the amplitude setting. For this reason, the actual output characteristics should be verified by measuring the main output or the monitor output. For high-accuracy applications requiring traceable calibration, verify the output with a calibrated oscilloscope.			
Included pulse transformers:	None			
Power requirements:	100 - 240 Volts, 50 - 60 Hz			
Dimensions (H x W x D):	100 mm x 430 mm x 375 mm (3.9" x 17" x 14.8")			
Rack-mount kit:	Optional. Add -R5 to the model number.			
Temperature range:	+5°C to +40°C			

- 1) -B suffix indicates IEEE-488.2 GPIB and RS-232 control of amplitude, pulse width, PRF and delay. (See <http://www.avtechpulse.com/gpib>).
- 2) Indicate desired polarity by suffixing model number with -P or -N (i.e. positive or negative) or -PN for the dual-polarity option (one output with switchable polarity).
- 3) This is the input in series with the output, internally. Since the output impedance is not 50 Ohms, the load impedance must be 50 Ohms, or transmission line reflections will occur.
- 4) For DC offset option suffix model number with -OS.
- 5) A 50 Ohm load is required. Other loads may damage the instrument. Consult Avtech ([info@avtechpulse.com](mailto:info@avtechpulse.com)) if you need to drive other load

- 6) The maximum amplitude may fall by up to 10% at minimum pulse width, as the rise and fall times become comparable to the pulse width.
- 7) The fall time varies with amplitude (higher amplitudes produce faster fall times) and pulse width (wider pulse widths produce slower fall times). These values are the limits for operation at minimum and maximum specified amplitudes and pulse widths. Fall times for other settings will lie between these values.
- 8) Add the -DPF model number suffix to specify the double pulse option.
- 9) Add the -SIL model number suffix to specify the safety interlock option.

## -DPF DOUBLE PULSE OPTION

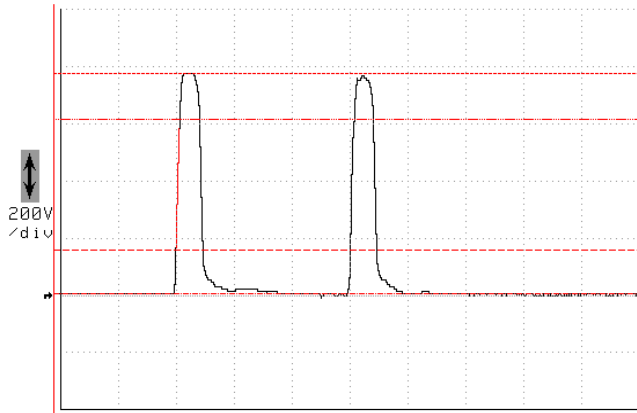

Amplitude	Rise	Fall	Width	Main Size
768.0V	3.45011 ns	3.05668 ns	20.2273 ns	50ns/div
				Main Pos
				23.1ns

The -DPF option adds the ability to generate pulse doublets, instead of single pulses. The first and second pulses in the doublet have independently variable amplitude and pulse width. Both must have the same polarity. (For dual-polarity models, the polarity setting will affect both pulses in the doublet.)

In the internal trigger mode, the delay of the first pulse is adjustable over a range of 0 to 1.0 seconds, relative to the SYNC output. The second pulse is delayed relative to the first by an adjustable setting of 150 ns to 1.0 seconds (not to exceed 50% of the period). The separation resolution varies, but it is always better than 0.15% of (programmed separation + 20 ns).

Two external trigger modes are provided. In the “Single External Trigger” mode, external trigger pulses are applied to one connector. Each external pulse triggers a

pulse doublet, after a short fixed propagation delay (approximately 200 ns). The doublet amplitudes, pulse widths, and delays are controlled in the same manner as the internal trigger mode.

The “Double External Trigger” mode uses two external trigger connectors. A pulse on the first trigger connector (TRIG1) generates the first output pulse after a short fixed propagation delay and a variable delay (PROP1 + DLY1), with amplitude AMP1 and pulse width PW1. A pulse on the second trigger connector (TRIG2) generates the second output pulse after a short fixed propagation delay and a variable delay (PROP2 + DLY2), with amplitude AMP2 and pulse width PW2. As with the other modes, both output pulses appear on the same output connector. The user must ensure that the delay between the first output pulse and the second pulse is between 150 ns to 1s (and less than 50% of the period). The timing between the two pulses within the doublet is controlled by the DLY1 and DLY2 settings *and* the timing between the trigger pulses.

### Internal Trigger mode waveforms:

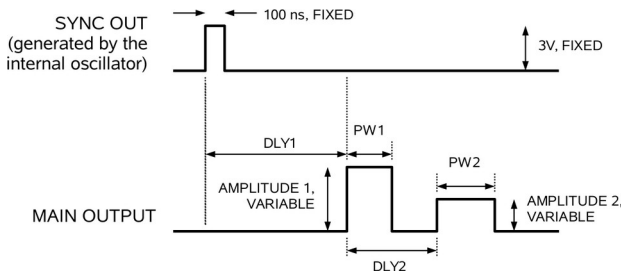

### Single External Trigger mode waveforms:

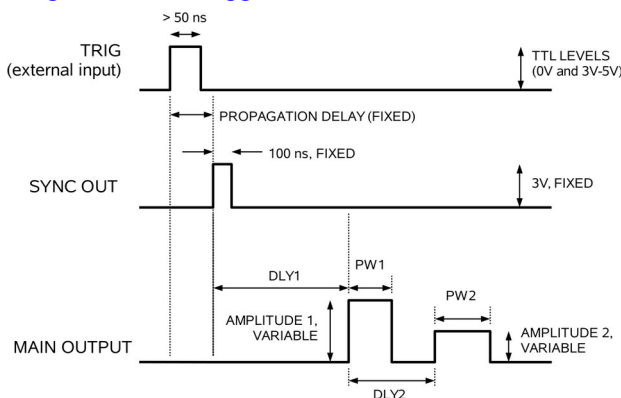

### Double External Trigger mode waveforms:

