



AVTECH ELECTROSYSTEMS LTD.

NANOSECOND WAVEFORM ELECTRONICS
SINCE 1975

P.O. BOX 265
OGDENSBURG, NY
U.S.A. 13669-0265

TEL: 888-670-8729 (USA & Canada) or +1-613-686-6675 (Intl)
FAX: 800-561-1970 (USA & Canada) or +1-613-686-6679 (Intl)

info@avtechpulse.com - <http://www.avtechpulse.com/>

BOX 5120, LCD MERIVALE
OTTAWA, ONTARIO
CANADA K2C 3H5

INSTRUCTIONS

MODEL AV-143B

×5 GAIN, ±20V OUTPUT

PULSE AMPLIFIER

WITH 50 ns RISE AND FALL TIMES

SERIAL NUMBER: _____

WARRANTY

Avtech Electrosystems Ltd. warrants products of its manufacture to be free from defects in material and workmanship under conditions of normal use. If, within one year after delivery to the original owner, and after prepaid return by the original owner, this Avtech product is found to be defective, Avtech shall at its option repair or replace said defective item. This warranty does not apply to units which have been disassembled, modified or subjected to conditions exceeding the applicable specifications or ratings. This warranty is the extent of the obligation assumed by Avtech with respect to this product and no other warranty or guarantee is either expressed or implied.

TECHNICAL SUPPORT

Phone: 888-670-8729 (USA & Canada) or +1-613-686-6675 (International)

Fax: 800-561-1970 (USA & Canada) or +1-613-686-6679 (International)

E-mail: info@avtechpulse.com

World Wide Web: <http://www.avtechpulse.com>

TABLE OF CONTENTS

WARRANTY.....2

TECHNICAL SUPPORT.....2

TABLE OF CONTENTS.....3

INTRODUCTION.....4

SPECIFICATIONS.....4

REGULATORY NOTES.....5

FCC PART 18.....5

EC DECLARATION OF CONFORMITY.....5

DIRECTIVE 2011/65/EU (RoHS).....6

DIRECTIVE 2002/96/EC (WEEE).....6

CONTROLS.....8

POWER SUPPLIES.....8

PROTECTING YOUR INSTRUMENT.....8

BASIC TEST ARRANGEMENT.....9

PERFORMANCE CHECK SHEET(S).....10

Manual Reference: /fileserver2/officefiles/instructword/av-143/AV-143B,ed5.odt.
Last modified May 14, 2018.
Copyright © 2018 Avtech Electrosystems Ltd, All Rights Reserved.

INTRODUCTION

The Model AV-143B is a DC-powered pulse amplifier module with a fixed gain of +5 and a bandwidth of DC – 10 MHz. Output voltages of up to $\pm 20\text{V}$ can be generated into load impedances of 50Ω or higher.

SPECIFICATIONS

Model:	AV-143B
Output amplitude: (max) ($R_L = 50\ \Omega$)	$\pm 20\text{V}$
Voltage gain:	+5
Rise, fall time (20%-80%) ¹ :	$\leq 50\ \text{ns}$
Input impedance ¹ :	1 k Ω
Output impedance:	2 Ω
Bandwidth:	DC - 10 MHz
Power out: (max)	8 Watt
Overshoot:	$\leq 6\%$
Prime power:	$\pm 24\text{V}, 0.6\text{A}$
Connectors:	BNC
Dimensions:	Avtech Style A, 43 mm x 66 mm x 109 mm (1.7" x 2.6" x 4.3")

1) For an output pulse swinging from zero Volts to the maximum positive output voltage.

REGULATORY NOTES

FCC PART 18

This device complies with part 18 of the FCC rules for non-consumer industrial, scientific and medical (ISM) equipment.

This instrument is enclosed in a rugged metal chassis and uses a filtered power entry module (where applicable). The main output signal is provided on a shielded connector that is intended to be used with shielded coaxial cabling and a shielded load. Under these conditions, the interference potential of this instrument is low.

If interference is observed, check that appropriate well-shielded cabling is used on the output connectors. Contact Avtech (info@avtechpulse.com) for advice if you are unsure of the most appropriate cabling. Also, check that your load is adequately shielded. It may be necessary to enclose the load in a metal enclosure.

If any of the connectors on the instrument are unused, they should be covered with shielded metal "dust caps" to reduce the interference potential.

This instrument does not normally require regular maintenance to minimize interference potential. However, if loose hardware or connectors are noted, they should be tightened. Contact Avtech (info@avtechpulse.com) if you require assistance.

EC DECLARATION OF CONFORMITY



We Avtech Electrosystems Ltd.
 P.O. Box 5120, LCD Merivale
 Ottawa, Ontario
 Canada K2C 3H5

declare that this pulse generator meets the intent of Directive 2004/108/EG for Electromagnetic Compatibility. Compliance pertains to the following specifications as listed in the official Journal of the European Communities:

EN 50081-1 Emission

EN 50082-1 Immunity

and that this pulse generator meets the intent of the Low Voltage Directive 2006/95/EC. Compliance pertains to the following specifications as listed in the official Journal of the European Communities:

EN 61010-1:2001 Safety requirements for electrical equipment for measurement, control, and laboratory use

DIRECTIVE 2011/65/EU (RoHS)

We Avtech Electrosystems Ltd.
P.O. Box 5120, LCD Merivale
Ottawa, Ontario
Canada K2C 3H5

declare that, to the best of our knowledge, all electrical and electronic equipment (EEE) sold by the company are in compliance with Directive 2011/65/EU of the European Parliament and of the Council of 8 June 2011 on the restriction of the use of certain hazardous substances in electrical and electronic equipment (also known as “RoHS Recast”). In addition, this declaration of conformity is issued under the sole responsibility of Avtech Electrosystems Ltd. Specifically, products manufactured do not contain the substances listed in the table below in concentrations greater than the listed maximum value.

<i>Material/Substance</i>	<i>Threshold level</i>
Lead (Pb)	< 1000 ppm (0.1% by mass)
Mercury (Hg)	< 1000 ppm (0.1% by mass)
Hexavalent Chromium (Cr6+)	< 1000 ppm (0.1% by mass)
Polybrominated Biphenyls (PBB)	< 1000 ppm (0.1% by mass)
Polybrominated Diphenyl ethers (PBDE)	< 1000 ppm (0.1% by mass)
Cadmium (Cd)	< 100 ppm (0.01% by mass)

DIRECTIVE 2002/96/EC (WEEE)

European customers who have purchased this equipment directly from Avtech will have completed a “WEEE Responsibility Agreement” form, accepting responsibility for WEEE compliance (as mandated in Directive 2002/96/EC of the European Union and local laws) on behalf of the customer, as provided for under Article 9 of Directive 2002/96/EC.

Customers who have purchased Avtech equipment through local representatives should consult with the representative to determine who has responsibility for WEEE

compliance. Normally, such responsibilities will lie with the representative, unless other arrangements (under Article 9) have been made.

Requirements for WEEE compliance may include registration of products with local governments, reporting of recycling activities to local governments, and financing of recycling activities.

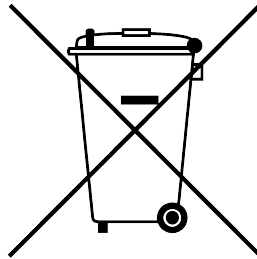

CONTROLS

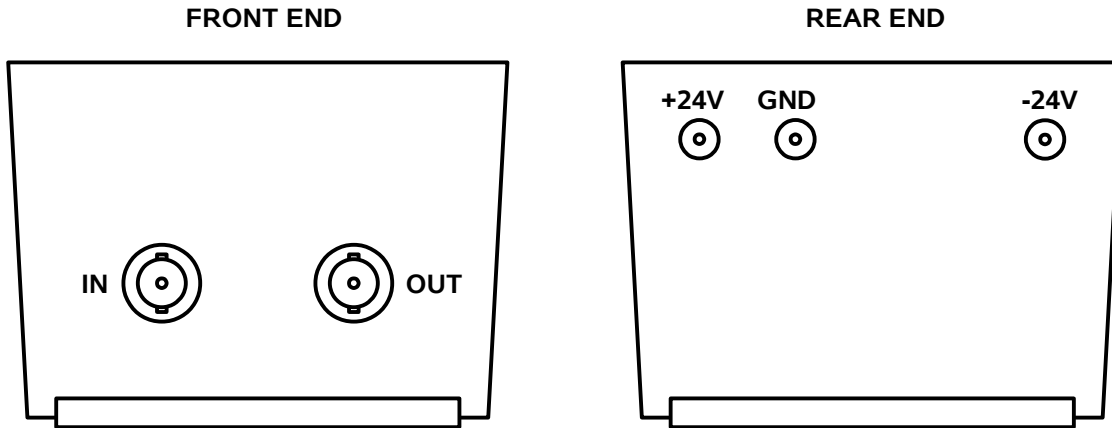

The input and output BNC connectors are located on the front end of the module, as shown above. The +24V, -24V, and GND input solder terminals are located on the opposite end.

A DC offset nulling trimpot (labeled “OS”) is accessible from the top side. It may be adjusted using a small screwdriver, if necessary.

POWER SUPPLIES

The AV-143B must be supplied with DC power supplies of +24V and -24V (as well as a ground connection).

The power supply inputs are protected from excessive voltages and incorrect polarities by externally-mounted (and replaceable) 1N4750A Zener diodes. These diodes may be damaged by reversed polarities, or voltages exceeding $\pm 27\text{V}$.

PROTECTING YOUR INSTRUMENT

The input and output circuits do contain some over-voltage protection circuitry. However, failures due to the application of excessive input voltages ($> \pm 4\text{V}$) are not covered by warranty.

BASIC TEST ARRANGEMENT

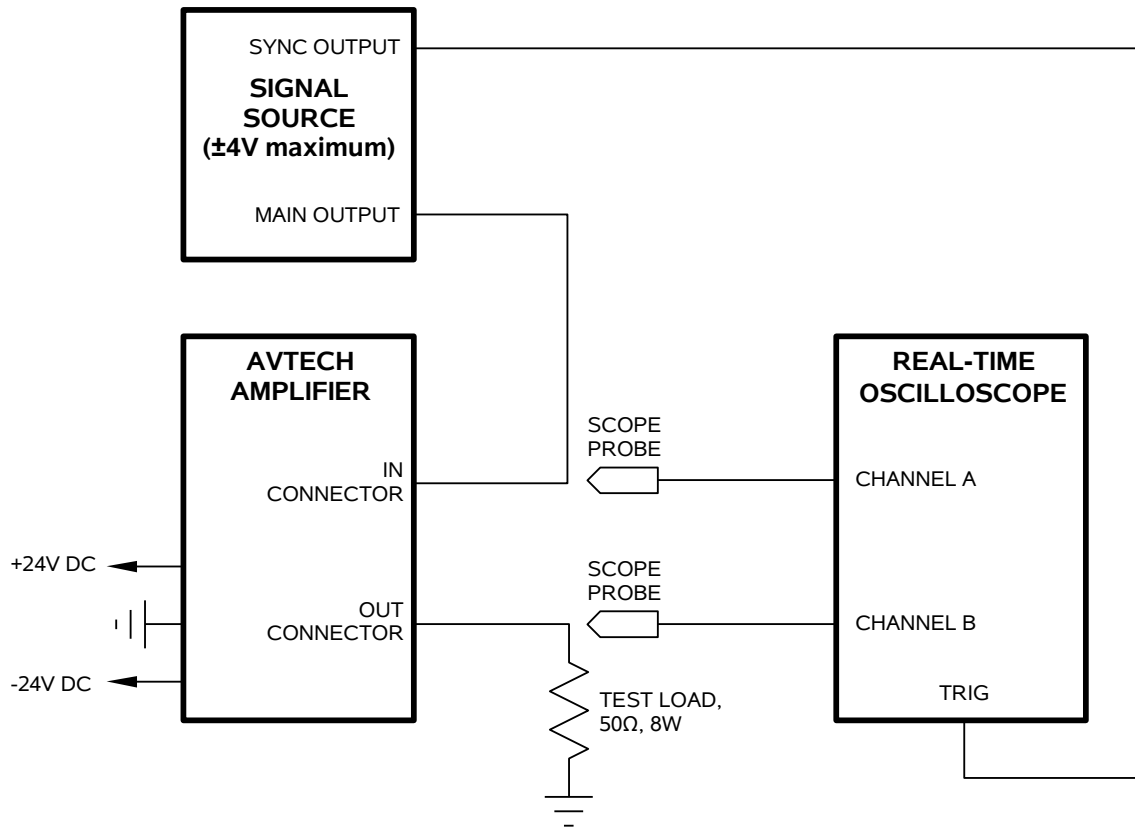

The recommended test set-up is shown above.

The bandwidth capability of components and instruments used to display the pulse generator output signal (attenuators, cables, connectors, etc.) should exceed 300 MHz.

PERFORMANCE CHECK SHEET(S)