



AVTECH ELECTROSYSTEMS LTD.

NANOSECOND WAVEFORM ELECTRONICS  
SINCE 1975

info@avtechpulse.com  
<http://www.avtechpulse.com/>

Tel: 888-670-8729 (USA & Canada)  
or +1-613-686-6675 (Worldwide)

BOX 5120, LCD MERIVALE  
OTTAWA, CANADA K2C3H5

## INSTRUCTIONS

MODEL AV-153AH-B

±200V AMPLITUDE

HIGH-VOLTAGE FUNCTION GENERATOR

AND VARIABLE-GAIN LINEAR AMPLIFIER

WITH IEEE 488.2 / RS-232 / ETHERNET CONTROL

SERIAL NUMBER: 14496

### WARRANTY

Avtech Electrosystems Ltd. warrants products of its manufacture to be free from defects in material and workmanship under conditions of normal use. If, within one year after delivery to the original owner, and after prepaid return by the original owner, this Avtech product is found to be defective, Avtech shall at its option repair or replace said defective item. This warranty does not apply to units which have been disassembled, modified or subjected to conditions exceeding the applicable specifications or ratings. This warranty is the extent of the obligation assumed by Avtech with respect to this product and no other warranty or guarantee is either expressed or implied.

### TECHNICAL SUPPORT

Phone: 888-670-8729 (USA & Canada)  
or +1-613-686-6675 (Worldwide)

E-mail: [info@avtechpulse.com](mailto:info@avtechpulse.com)  
World Wide Web: <http://www.avtechpulse.com>

## TABLE OF CONTENTS

<b>WARRANTY.....</b>	<b>2</b>
<b>TECHNICAL SUPPORT.....</b>	<b>2</b>
<b>TABLE OF CONTENTS.....</b>	<b>3</b>
<b>INTRODUCTION.....</b>	<b>6</b>
<b>AVAILABLE OPTIONS.....</b>	<b>6</b>
<b>HIGH-VOLTAGE PRECAUTIONS.....</b>	<b>7</b>
<b>SPECIFICATIONS.....</b>	<b>8</b>
<b>REGULATORY NOTES.....</b>	<b>9</b>
<b>FCC PART 18.....</b>	<b>9</b>
<b>EC DECLARATION OF CONFORMITY.....</b>	<b>9</b>
<b>DIRECTIVE 2011/65/EU (RoHS).....</b>	<b>10</b>
<b>DIRECTIVE 2002/96/EC (WEEE).....</b>	<b>10</b>
<b>FIRMWARE LICENSING.....</b>	<b>11</b>
<b>INSTALLATION.....</b>	<b>12</b>
<b>VISUAL CHECK.....</b>	<b>12</b>
<b>POWER RATINGS.....</b>	<b>12</b>
<b>CONNECTION TO THE POWER SUPPLY.....</b>	<b>12</b>
<b>PROTECTION FROM ELECTRIC SHOCK.....</b>	<b>13</b>
<b>ENVIRONMENTAL CONDITIONS.....</b>	<b>14</b>
<b>LABVIEW DRIVERS.....</b>	<b>14</b>
<b>FUSES.....</b>	<b>15</b>
<b>AC FUSE REPLACEMENT.....</b>	<b>15</b>
<b>DC FUSE REPLACEMENT.....</b>	<b>16</b>
<b>FUSE RATINGS.....</b>	<b>16</b>
<b>FRONT PANEL CONTROLS.....</b>	<b>17</b>
<b>REAR PANEL CONTROLS.....</b>	<b>19</b>
<b>GENERAL INFORMATION.....</b>	<b>21</b>
<b>WAVESHAPES SELECTION.....</b>	<b>21</b>
<b>SINE, TRIANGLE, AND SQUARE WAVE GENERATION.....</b>	<b>21</b>
<b>PULSE GENERATION.....</b>	<b>22</b>
<b>AMPLIFY MODE.....</b>	<b>22</b>
<b>RESISTIVE AND CAPACITIVE LOADS.....</b>	<b>23</b>
<b>PREVENTING DAMAGE.....</b>	<b>24</b>

DC OFFSET.....	24
<b>-PANB BURST MODE OPTION.....</b>	<b>25</b>
LOCAL MODE.....	25
REMOTE MODE.....	25
SYNC OUTPUT.....	26
<b>OPERATIONAL CHECK.....</b>	<b>27</b>
<b>PROGRAMMING YOUR PULSE GENERATOR.....</b>	<b>30</b>
KEY PROGRAMMING COMMANDS.....	30
ALL PROGRAMMING COMMANDS.....	32
<b>MECHANICAL INFORMATION.....</b>	<b>34</b>
TOP COVER REMOVAL.....	34
RACK MOUNTING.....	34
ELECTROMAGNETIC INTERFERENCE.....	34
<b>MAINTENANCE.....</b>	<b>35</b>
REGULAR MAINTENANCE.....	35
CLEANING.....	35
TRIGGER DAMAGE.....	35
<b>OTHER INFORMATION.....</b>	<b>36</b>
APPLICATION NOTES.....	36
MANUAL FEEDBACK.....	36
<b>WIRING DIAGRAMS.....</b>	<b>37</b>
WIRING OF AC POWER.....	37
WIRING OF DC POWER SUPPLIES.....	38
WIRING OF HV POWER SUPPLIES.....	39
PCB 158R7 - LOW VOLTAGE POWER SUPPLY.....	40
PCB 170C - HIGH-VOLTAGE POWER SUPPLY.....	41
PCB 155E - WAVEFORM GENERATOR, 1/4.....	42
PCB 155E - WAVEFORM GENERATOR, 2/4.....	43
PCB 155E - WAVEFORM GENERATOR, 3/4.....	44
PCB 155E - WAVEFORM GENERATOR, 4/4.....	45
PCB 107E - BURST PANB OPTION, 1/2.....	46
PCB 107E - BURST PANB OPTION, 2/2.....	47
PCB 335C - SYNC BUFFER.....	48
PCB 104H - KEYPAD / DISPLAY BOARD.....	49
PCB 295G - MAIN CONTROL BOARD, 1 OF 13, TOP-LEVEL.....	50

PCB 295G - MAIN CONTROL BOARD, 2 OF 13, MICROCONTROLLER TOP-LEVEL.....51  
PCB 295G - MAIN CONTROL BOARD, 3 OF 13, EMBEDDED CONTROLLER.....52  
PCB 295G - MAIN CONTROL BOARD, 4 OF 13, GPIB INTERFACE.....53  
PCB 295G - MAIN CONTROL BOARD, 5 OF 13, DACs.....54  
PCB 295G - MAIN CONTROL BOARD, 6 OF 13, TIMING TOP-LEVEL.....55  
PCB 295G - MAIN CONTROL BOARD, 7 OF 13, GATE CIRCUIT.....56  
PCB 295G - MAIN CONTROL BOARD, 8 OF 13, OSCILLATOR.....57  
PCB 295G - MAIN CONTROL BOARD, 9 OF 13, TTL OUTPUTS.....58  
PCB 295G - MAIN CONTROL BOARD, 10 OF 13, DELAY CIRCUITS.....59  
PCB 295G - MAIN CONTROL BOARD, 11 OF 13, PULSE WIDTH CIRCUIT.....60  
PCB 295G - MAIN CONTROL BOARD, 12 OF 13, TRIGGER SELECT.....61  
PCB 295G - MAIN CONTROL BOARD, 13 OF 13, SHIFT REGISTERS.....62  
MAIN WIRING.....63  
**PERFORMANCE CHECK SHEET.....64**

Manual Reference: /fileserver1/officefiles/instructword/av-151-153/AV-153AH-B,sn14496.odt.  
Last modified January 24, 2025.  
Copyright © 2025 Avtech Electrosystems Ltd, All Rights Reserved.

## INTRODUCTION

The AV-153AH-B is a high-performance GPIB/RS232/Ethernet-equipped function generator that can produce square, sine, triangle, and pulse outputs at frequencies up to 300 kHz, with peak amplitudes of up to 200V. For the sine, triangle, and square wave modes, this produces peak-to-peak amplitudes of up to 400V.

The AV-153AH-B will drive load impedances of 1.2 k $\Omega$  or higher. The AV-153AH-B can also drive capacitive loads, at reduced frequencies.

When supplied with an external voltage input, the AV-153AH-B may be used as a DC to 300 kHz variable-gain linear amplifier. The gain is variable from +1 to +100.

The AV-153AH-B features front panel keyboard and adjust knob control of the output pulse parameters along with a four line by 40 character back-lit LCD display of the output amplitude, waveshape, and frequency. The instrument includes memory to store up to four complete instrument setups. The operator may use the front panel or the computer interface to store a complete "snapshot" of all key instrument settings, and recall this setup at a later time.

This instrument is intended for use in research, development, test and calibration laboratories by qualified personnel.

## AVAILABLE OPTIONS

-PANB Option: The -PANB option allows the generation of a burst of 1-500 cycles of sine, square, triangle, or pulse waveforms. This burst may be triggered by pressing a front-panel pushbutton, or by computer command.

-R5 Option: This is the optional rack-mounting kit. The R5 rack-mount kit may also be ordered separately.

## HIGH-VOLTAGE PRECAUTIONS

 **CAUTION:** This instrument provides output voltages as high as  $\pm 200$  Volts, so extreme caution must be employed when using this instrument. The instrument should only be used by individuals who are thoroughly skilled in high voltage laboratory techniques. The following precaution should always be observed:

1. Keep exposed high-voltage wiring to an absolute minimum.
2. Wherever possible, use shielded connectors and cabling.
3. Connect and disconnect loads and cables only when the amplifier is turned off.
4. Keep in mind that all cables, connectors, oscilloscope probes, and loads must have an appropriate voltage rating.
5. Do not attempt any repairs on the instrument, beyond the fuse replacement procedures described in this manual. Contact Avtech technical support (see page 2 for contact information) if the instrument requires servicing.

## SPECIFICATIONS

Model:	AV-153AH-B <sup>1</sup>
Maximum amplitude & maximum peak output <sup>2</sup> :	0 to $\pm$ 200 Volts
DC offset <sup>2</sup> :	0 to $\pm$ 200 Volts
Load resistance:	$\geq$ 1.2 k $\Omega$
Output resistance <sup>3</sup> : (in series with output)	20 $\Omega$ , approx.
Average output power:	50 Watts maximum
Minimum frequency:	1 Hz
Maximum frequency: (for a given load resistance and capacitance) <sup>4</sup> :	300 kHz (1.2 k $\Omega$    0 nF) 150 kHz (1.2 k $\Omega$    1 nF) 50 kHz (1.2 k $\Omega$    3 nF) 15 kHz (1.2 k $\Omega$    6.8 nF)
Square wave rise time: (for a given load resistance and capacitance) <sup>4,6</sup> :	1 $\mu$ s (1.2 k $\Omega$    0 nF) 1.2 $\mu$ s (1.2 k $\Omega$    1 nF) 2.7 $\mu$ s (1.2 k $\Omega$    3 nF) 7 $\mu$ s (1.2 k $\Omega$    6.8 nF)
Waveforms:	Sine, square, triangle, pulse, and amplifier mode.
Amplifier mode:	Input amplitude for maximum output: $\pm$ 2 Volts (1 k $\Omega$ input impedance)
Pulse width (FWHM):	1 $\mu$ s to 500 ms. 80% max. duty cycle.
Burst mode:	Optional <sup>7</sup> . This allows the generation of a burst of 1-500 cycles of sine, square, triangle, or pulse waveforms. This burst may be triggered by pressing a front-panel pushbutton, or by computer command.
GPIB / RS-232 control <sup>1</sup> :	Standard on -B units.
Ethernet port, for remote control using VXI-11.3, ssh, telnet, & web:	Included. Recommended as a modern alternative to GPIB / RS-232. See <a href="http://www.avtechpulse.com/options/vxi">http://www.avtechpulse.com/options/vxi</a> for details.
Connectors:	BNC
Power requirement:	100 - 240 Volts, 50 - 60 Hz
Dimensions:	100 mm x 430 mm x 375 mm 3.9" x 17" x 14.8" (H x W x D)

- 1) -B suffix indicates IEEE-488.2 GPIB and RS-232 control of amplitude and frequency. See <http://www.avtechpulse.com/gpib/> for details.
- 2) Peak output = amplitude + offset. The amplitude and offset can not be set to maximum at the same time, or the peak output rating will be exceeded.
- 3) The non-zero output impedance ( $R_{OUT}$ ) will reduce the maximum output amplitude slightly when operating into low load impedances. That is,  $V_{OUT} = V_{SET} \times R_{LOAD} / (R_{LOAD} + R_{OUT})$ , where  $V_{SET}$  is the programmed amplitude and  $R_{LOAD}$  is the load resistance.
- 4) The || symbol means "in parallel with".
- 5) Contact the factory ([info@avtechpulse.com](mailto:info@avtechpulse.com)) for characterization of frequency or rise time under other load conditions.
- 6) The non-zero rise time will also distort the sine and triangle waveforms when operating near the maximum rated frequency. All rise times are measured on a 20%-80% basis.
- 7) Add the suffix -PANB to the model number to specify the burst mode option.



## REGULATORY NOTES

### FCC PART 18

This device complies with part 18 of the FCC rules for non-consumer industrial, scientific and medical (ISM) equipment.

This instrument is enclosed in a rugged metal chassis and uses a filtered power entry module (where applicable). The main output signal is provided on a shielded connector that is intended to be used with shielded coaxial cabling and a shielded load. Under these conditions, the interference potential of this instrument is low.

If interference is observed, check that appropriate well-shielded cabling is used on the output connectors. Contact Avtech ([info@avtechpulse.com](mailto:info@avtechpulse.com)) for advice if you are unsure of the most appropriate cabling. Also, check that your load is adequately shielded. It may be necessary to enclose the load in a metal enclosure.

If any of the connectors on the instrument are unused, they should be covered with shielded metal "dust caps" to reduce the interference potential.

This instrument does not normally require regular maintenance to minimize interference potential. However, if loose hardware or connectors are noted, they should be tightened. Contact Avtech ([info@avtechpulse.com](mailto:info@avtechpulse.com)) if you require assistance.

### EC DECLARATION OF CONFORMITY



We                    Avtech Electrosystems Ltd.  
                          P.O. Box 5120, LCD Merivale  
                          Ottawa, Ontario  
                          Canada K2C 3H5

declare that this pulse generator meets the intent of Directive 2004/108/EG for Electromagnetic Compatibility. Compliance pertains to the following specifications as listed in the official Journal of the European Communities:

EN 50081-1 Emission

EN 50082-1 Immunity

and that this pulse generator meets the intent of the Low Voltage Directive 2006/95/EC. Compliance pertains to the following specifications as listed in the official Journal of the European Communities:

EN 61010-1:2001 Safety requirements for electrical equipment for measurement, control, and laboratory use

DIRECTIVE 2011/65/EU (RoHS)

We Avtech Electrosystems Ltd.  
P.O. Box 5120, LCD Merivale  
Ottawa, Ontario  
Canada K2C 3H5

declare that, to the best of our knowledge, all electrical and electronic equipment (EEE) sold by the company are in compliance with Directive 2011/65/EU of the European Parliament and of the Council of 8 June 2011 on the restriction of the use of certain hazardous substances in electrical and electronic equipment (also known as “RoHS Recast”). In addition, this declaration of conformity is issued under the sole responsibility of Avtech Electrosystems Ltd. Specifically, products manufactured do not contain the substances listed in the table below in concentrations greater than the listed maximum value.

<i>Material/Substance</i>	<i>Threshold level</i>
Lead (Pb)	< 1000 ppm (0.1% by mass)
Mercury (Hg)	< 1000 ppm (0.1% by mass)
Hexavalent Chromium (Cr6+)	< 1000 ppm (0.1% by mass)
Polybrominated Biphenyls (PBB)	< 1000 ppm (0.1% by mass)
Polybrominated Diphenyl ethers (PBDE)	< 1000 ppm (0.1% by mass)
Cadmium (Cd)	< 100 ppm (0.01% by mass)
Bis(2-ethylhexyl) phthalate (DEHP)	< 1000 ppm (0.1% by mass)
Butyl benzyl phthalate (BBP)	< 1000 ppm (0.1% by mass)
Dibutyl phthalate (DBP)	< 1000 ppm (0.1% by mass)
Diisobutyl phthalate (DIBP)	< 1000 ppm (0.1% by mass)

DIRECTIVE 2002/96/EC (WEEE)

European customers who have purchased this equipment directly from Avtech will have completed a “WEEE Responsibility Agreement” form, accepting responsibility for WEEE

compliance (as mandated in Directive 2002/96/EC of the European Union and local laws) on behalf of the customer, as provided for under Article 9 of Directive 2002/96/EC.

Customers who have purchased Avtech equipment through local representatives should consult with the representative to determine who has responsibility for WEEE compliance. Normally, such responsibilities will lie with the representative, unless other arrangements (under Article 9) have been made.

Requirements for WEEE compliance may include registration of products with local governments, reporting of recycling activities to local governments, and financing of recycling activities.

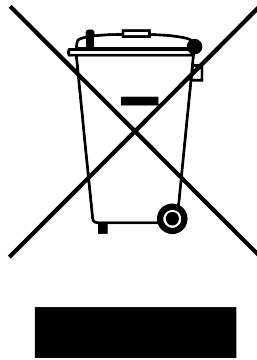

## FIRMWARE LICENSING

This instrument uses open-source software internally, and is built on a Fedora Linux operating system.

Some of this software requires that the source code be made available to the user as a condition of its licensing. The source code for programs used by Fedora is freely available at <https://src.fedoraproject.org/>.

The source code for modifications implemented by Avtech, and for Avtech-specific programs, is available at <https://www.avtechpulse.com/cgit/Instrument.git/>.

## INSTALLATION

### VISUAL CHECK

After unpacking the instrument, examine to ensure that it has not been damaged in shipment. Visually inspect all connectors, knobs, liquid crystal displays (LCDs), and the handles. Confirm that a power cord, a GPIB cable, and two instrumentation manuals (this manual and the “Programming Manual for -B Instruments”) are with the instrument. If the instrument has been damaged, file a claim immediately with the company that transported the instrument.

### POWER RATINGS

This instrument is intended to operate from 100 - 240 V, 50 - 60 Hz.

The maximum power consumption is 115 Watts. Please see the “FUSES” section for information about the appropriate AC and DC fuses.

This instrument is an “Installation Category II” instrument, intended for operation from a normal single-phase supply.

### CONNECTION TO THE POWER SUPPLY

An IEC-320 three-pronged recessed male socket is provided on the back panel for AC power connection to the instrument. One end of the detachable power cord that is supplied with the instrument plugs into this socket. The other end of the detachable power cord plugs into the local mains supply. Use only the cable supplied with the instrument. The mains supply must be earthed, and the cord used to connect the instrument to the mains supply must provide an earth connection. (The supplied cord does this.)

 Warning: Failure to use a grounded outlet may result in injury or death due to electric shock. This product uses a power cord with a ground connection. It must be connected to a properly grounded outlet. The instrument chassis is connected to the ground wire in the power cord.

The table below describes the power cord that is normally supplied with this instrument, depending on the destination region:

Destination Region	Description	Option	Manufacturer	Part Number
United Kingdom, Hong Kong, Singapore, Malaysia	BS 1363, 230V, 50 Hz	-AC00	Qualtek	370001-E01
Australia, New Zealand	AS 3112:2000, 230-240V, 50 Hz	-AC01	Qualtek	374003-A01
Continental Europe, Korea, Indonesia, Russia	European CEE 7/7 "Schuko" 230V, 50 Hz	-AC02	Qualtek	364002-D01
North America, Taiwan	NEMA 5-15, 120V, 60 Hz	-AC03	Qualtek	312007-01
Switzerland	SEV 1011, 230V, 50 Hz	-AC06	Qualtek	378001-E01
South Africa, India	SABS 164-1, 220-250V, 50 Hz	-AC17	Volex	2131H 10 C3
Japan	JIS 8303, 100V, 50-60 Hz	-AC18	Qualtek	397002-01
Israel	SI 32, 220V, 50 Hz	-AC19	Qualtek	398001-01
China	GB 1002-1 / 2099-1, 220V, 50 Hz	-AC22	Qualtek	399012-01

## PROTECTION FROM ELECTRIC SHOCK

 Operators of this instrument must be protected from electric shock at all times. The owner must ensure that operators are prevented access and/or are insulated from every connection point. In some cases, connections must be exposed to potential human contact. Operators must be trained to protect themselves from the risk of electric shock. This instrument is intended for use by qualified personnel who recognize shock hazards and are familiar with safety precautions required to avoid possibly injury. In particular, operators should:

1. Keep exposed high-voltage wiring to an absolute minimum.
2. Wherever possible, use shielded connectors and cabling.
3. Connect and disconnect loads and cables only when the instrument is turned off.
4. Keep in mind that all cables, connectors, oscilloscope probes, and loads must have an appropriate voltage rating.
5. Do not attempt any repairs on the instrument, beyond the fuse replacement procedures described in this manual. Contact Avtech technical support (see page 2 for contact information) if the instrument requires servicing. Service is to be performed solely by qualified service personnel.

## ENVIRONMENTAL CONDITIONS

This instrument is intended for use under the following conditions:

1. indoor use;
2. altitude up to 2 000 m;
3. temperature 5 °C to 40 °C;
4. maximum relative humidity 80 % for temperatures up to 31 °C decreasing linearly to 50 % relative humidity at 40 °C;
5. Mains supply voltage fluctuations up to  $\pm 10$  % of the nominal voltage;
6. no pollution or only dry, non-conductive pollution.

## LABVIEW DRIVERS

A LabVIEW driver for this instrument is available for download on the Avtech web site, at <http://www.avtechpulse.com/labview>. A copy is also available in National Instruments' Instrument Driver Library at <http://www.natinst.com/>.

## FUSES

This instrument contains four fuses. All are accessible from the rear-panel. Two protect the AC prime power input, and two protect the internal DC power supplies. The locations of the fuses on the rear panel are shown in the figure below:

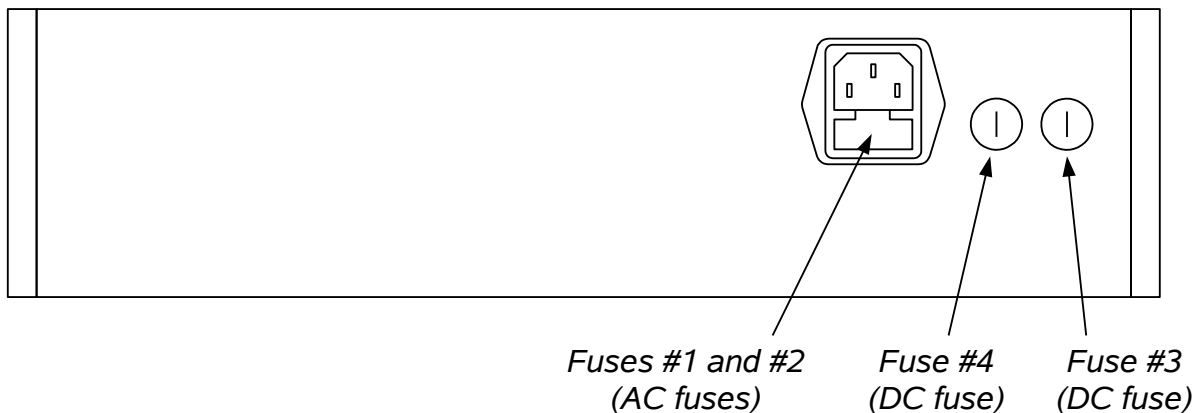

### AC FUSE REPLACEMENT

To physically access the AC fuses, the power cord must be detached from the rear panel of the instrument. The fuse drawer may then be extracted using a small flat-head screwdriver, as shown below:

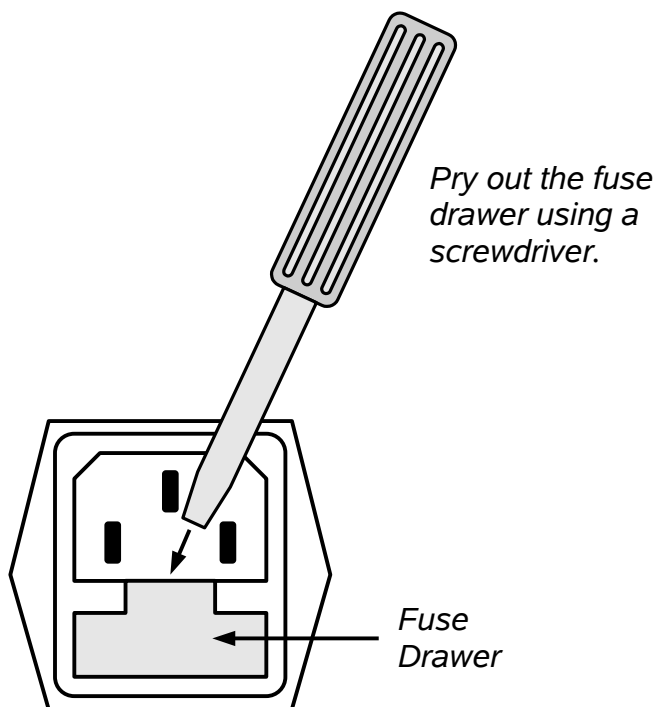

## DC FUSE REPLACEMENT

The DC fuses may be replaced by inserting the tip of a flat-head screwdriver into the fuse holder slot, and rotating the slot counter-clockwise. The fuse and its carrier will then pop out.

## FUSE RATINGS

The following table lists the required fuses:

Fuses	Nominal Mains Voltage	Rating	Case Size	Recommended Replacement Part	
				Littelfuse Part Number	Digi-Key Stock Number
#1, #2 (AC)	115 V	1.0A, 250V, Time-Delay	5×20 mm	0218001.HXP	F2419-ND
	230 V	0.5A, 250V, Time-Delay	5×20 mm	0218.500HXP	F2416-ND
#3 (DC)	N/A	1.6A, 250V, Time-Delay	5×20 mm	021801.6HXP	F2424-ND
#4 (DC)	N/A	4.0A, 250V, Time-Delay	5×20 mm	0218004.HXP	F2421-ND

The recommended fuse manufacturer is Littelfuse (<http://www.littelfuse.com>).

Replacement fuses may be easily obtained from Digi-Key (<http://www.digikey.com>) and other distributors.



## FRONT PANEL CONTROLS

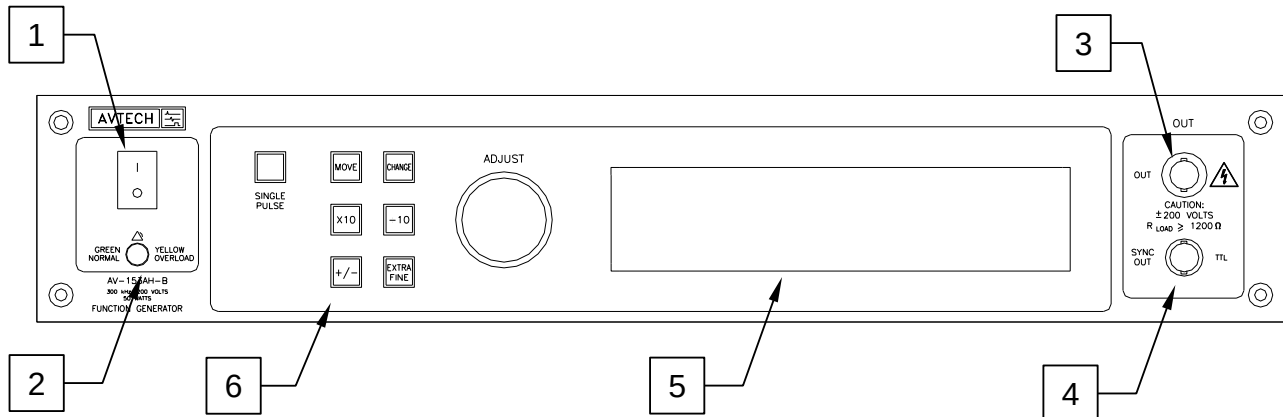

1. **POWER Switch.** This is the main power switch. When turning the instrument on, there is normally a delay of 10 seconds before anything is shown on the main display, as the internal operating system boots up.

If the main menu does not appear after 30 seconds, turn off the instrument and leave it off for at least 60 seconds before applying power again.

2. **OVERLOAD Indicator.** When the instrument is powered, this indicator is normally green, indicating normal operation. If this indicator is yellow, an internal automatic overload protection circuit has been tripped. If the unit is overloaded (by operating at an exceedingly high duty cycle or by operating into a very low impedance), the protective circuit will disable the output of the instrument and turn the indicator light yellow. The light will stay yellow (i.e. output disabled) for about 5 seconds after which the instrument will attempt to re-enable the output (i.e. light green) for about 1 second. If the overload condition persists, the output will be disabled again (i.e. light yellow) for another 5 seconds. If the overload condition has been removed, the instrument will resume normal operation.

This overload indicator may flash yellow briefly at start-up. This is not a cause for concern.

Note that the output stage will safely withstand a short-circuited load condition.

3. **OUT Connector.** This BNC connector provides the main output signal, into load impedances of  $> 1.2 \text{ k}\Omega$ .

 **Caution:** Voltages as high as  $\pm 200\text{V}$  may be present on the center conductor of this output connector. Avoid touching this conductor. Connect to this connector using standard coaxial cable, to ensure that the center conductor is not exposed.

4. **SYNC OUT.** This connector supplies a SYNC output that can be used to trigger other equipment, particularly oscilloscopes. This signal has an approximate

amplitude of +3 Volts to  $R_L > 1 \text{ k}\Omega$  with a pulse width of approximately 100 ns.

5. LIQUID CRYSTAL DISPLAY (LCD). This LCD is used in conjunction with the keypad to change the instrument settings. Normally, the main menu is displayed, which lists the key adjustable parameters and their current values. The "Programming Manual for -B Instruments" describes the menus and submenus in detail.
6. KEYPAD.

Control Name	Function
MOVE	This moves the arrow pointer on the display.
CHANGE	This is used to enter the submenu, or to select the operating mode, pointed to by the arrow pointer.
× 10	If one of the adjustable numeric parameters is displayed, this increases the setting by a factor of ten.
÷ 10	If one of the adjustable numeric parameters is displayed, this decreases the setting by a factor of ten.
+/-	If one of the adjustable numeric parameters is displayed, and this parameter can be both positive or negative, this changes the sign of the parameter.
EXTRA FINE	This changes the step size of the ADJUST knob. In the extra-fine mode, the step size is twenty times finer than in the normal mode. This button switches between the two step sizes.
ADJUST	This large knob adjusts the value of any displayed numeric adjustable values, such as frequency, pulse width, etc. The adjust step size is set by the "EXTRA FINE" button.  When the main menu is displayed, this knob can be used to move the arrow pointer.

## REAR PANEL CONTROLS

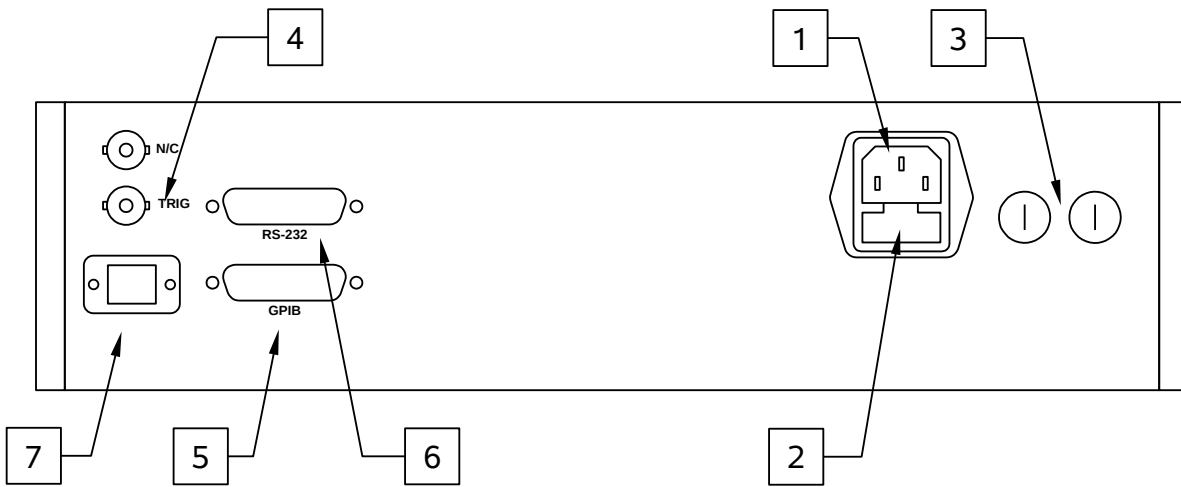

*Note: some connectors may be in different positions than shown above, depending on the exact combination of options ordered.*

1. AC POWER INPUT. An IEC-320 C14 three-pronged recessed male socket is provided on the back panel for AC power connection to the instrument. One end of the detachable power cord that is supplied with the instrument plugs into this socket.
2. AC FUSE DRAWER. The two fuses that protect the AC input are located in this drawer. Please see the “FUSES” section of this manual for more information.
3. DC FUSES. These two fuses protect the internal DC power supplies. Please see the “FUSES” sections of this manual for more information.
4. TRIG. When the AV-153AH-B is set to operate in the amplifier mode, the externally-generated input signal is applied to this connector. The maximum input voltage is  $\pm 2V$ . The input impedance of this input is  $1\text{ k}\Omega$ . (Depending on the length of cable attached to this input, and the source driving it, it may be desirable to add a coaxial 50 Ohm terminator to this input to provide a proper transmission line termination. The Pasternack ([www.pasternack.com](http://www.pasternack.com)) PE6008-50 BNC feed-thru 50 Ohm terminator is suggested for this purpose.)
5. GPIB Connector. A standard GPIB cable can be attached to this connector to allow the instrument to be computer-controlled. See the “Programming Manual for -B Instruments” for more details on GPIB control.
6. RS-232 Connector. A standard serial cable with a 25-pin male connector can be attached to this connector to allow the instrument to be computer-controlled. A user name (“admin”) and a password (“default”, as shipped from the factory) are required

when logging into a serial terminal session. The internal controller attempts to auto-sense the parity setting. It may be necessary to send a few return characters before attempting a login in order to provide enough data to allow this auto-sensing to work. (A standard Linux “agetty” process is used to implement serial control internally.) See the “Programming Manual for -B Instruments” for more details on RS-232 control.

7. Network Connector. This Ethernet connector allows the instrument to be remotely controlled using the VXI-11.3, ssh (secure shell), telnet, and http (web) protocols. See the “Programming Manual for -B Instruments” for more details.

## GENERAL INFORMATION

### WAVESHAPE SELECTION

The front-panel “SHAPE” menu or the “sour:func” computer command can be used to set the output waveform to one of five possible modes:

- SINE – This mode generates a bipolar sinusoidal signal with 50% duty cycle.
- TRIANGLE – This mode generates a bipolar triangle-wave signal with 50% duty cycle.
- SQUARE – This mode generates a bipolar square-wave signal with 50% duty cycle.
- PULSE – This mode generates a unipolar pulse signal, with adjustable pulse width.
- AMPLIFY – This mode causes the instrument to amplify an externally-generated signal.

### SINE, TRIANGLE, AND SQUARE WAVE GENERATION

When set to the SINE, TRIANGLE, or SQUARE modes, the output frequency and peak amplitude are controlled from the front panel (or by computer command). The output signal in these modes is bipolar (i.e., the signal swings from a positive value to an approximately equal negative amplitude), and the duty cycle is nominally 50% (i.e., time that the signal is positive is equal in length to the time that the signal is negative.)

These waveforms are illustrated below:

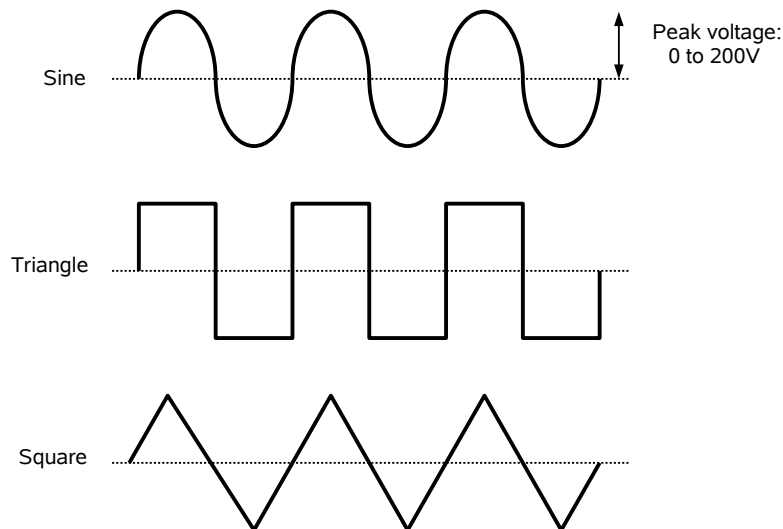

A SYNC output is provided on the front-panel. This provides a 100 ns, 3V signal for triggering oscilloscopes or other equipment. In these modes, the delay (or relative phase) between the main output and the SYNC output is not adjustable.

## PULSE GENERATION

The AV-153AH-B can also act as a pulse generator, with variable delay between the SYNC output and the main output. In this mode, the pulse width may be varied over a wide range (1  $\mu$ s to 500 ms), and the amplitude may be varied from 0 to +200V. (Negative pulses can not be generated directly. However, they can be generated indirectly by adding a negative DC offset. See the offset discussion below.) The maximum duty cycle ( $100\% \times \text{Pulse Width} / \text{Period}$ ) is 80%.

The outputs in this mode are shown below, assuming that the delay is set to a positive value:

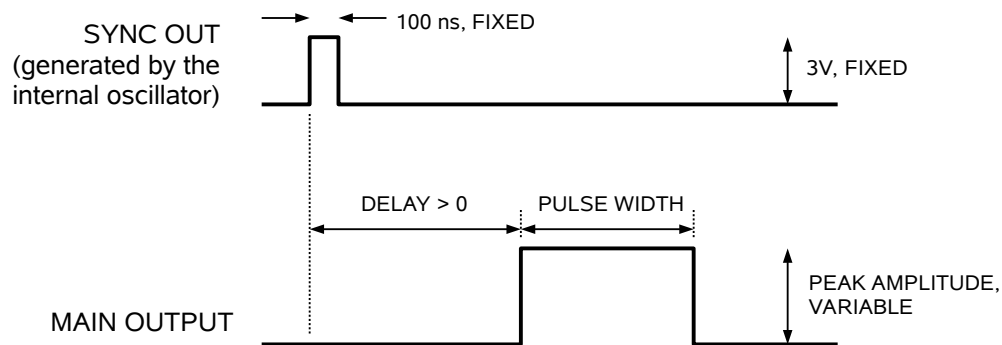

If the delay is negative, the order of the SYNC and OUT pulses is reversed:

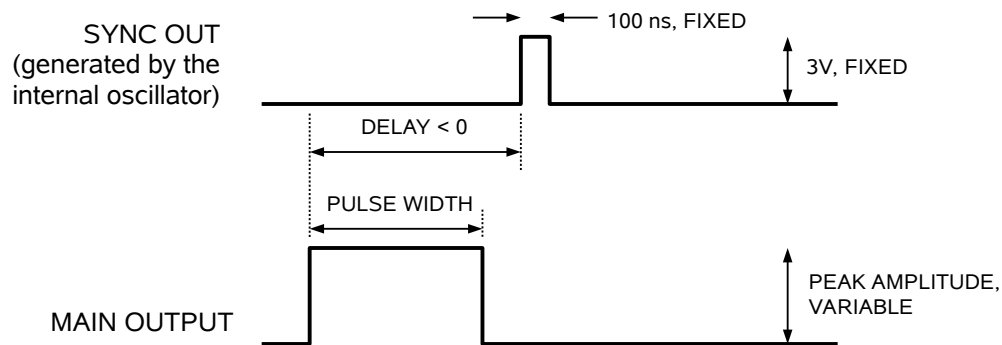

## AMPLIFY MODE

When the AMPLIFY mode is enabled, AV-153AH-B may be used as a DC-300 kHz variable-gain linear amplifier. The maximum gain is +100. The maximum input signal is  $\pm 2$ V. The gain is adjusted by varying the amplitude setting, which corresponds to the output that would be obtained for a +2V input. (For instance, to obtain a gain of +75, set the amplitude to +150V. If a -0.8V signal is applied, for instance, the actual output would be -60V, not +150V.)

The required voltage input signal is applied at TRIG for this mode of operation.

This mode is illustrated below:

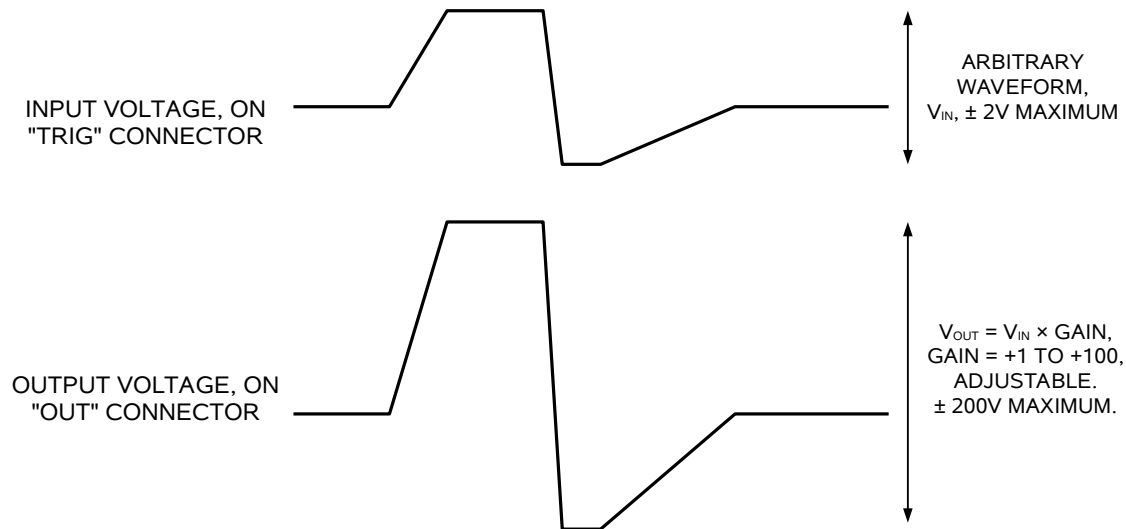

### RESISTIVE AND CAPACITIVE LOADS

The AV-153AH-B can drive resistive loads with impedances of 1.2 k $\Omega$  and higher. At reduced frequencies, the AV-153AH-B can also drive a capacitive load of up to 6.8 nF. The reduced maximum frequencies and increased rise times are outlined in the following table:

Maximum frequency: (for a given load resistance and capacitance) :	300 kHz (1.2 k $\Omega$    0 nF) 150 kHz (1.2 k $\Omega$    1 nF) 50 kHz (1.2 k $\Omega$    3 nF) 15 kHz (1.2 k $\Omega$    6.8 nF)
Squ. wave rise time: (for a given load resistance and capacitance) :	1 $\mu$ s (1.2 k $\Omega$    0 nF) 1.2 $\mu$ s (1.2 k $\Omega$    1 nF) 2.7 $\mu$ s (1.2 k $\Omega$    3 nF) 7 $\mu$ s (1.2 k $\Omega$    6.8 nF)

Please note that the capacitance figure includes the parasitic capacitance of any cabling, as well as the capacitance of the device under test. Common coaxial cable typically adds 15 pF per foot of cable.

The non-zero output impedance ( $R_{OUT} \approx 20\Omega$ ) will reduce the maximum output amplitude slightly when operating into low load impedances. That is,  $V_{OUT} = V_{SET} \times R_{LOAD} / (R_{LOAD} + R_{OUT})$ , where  $V_{SET}$  is the programmed amplitude and  $R_{LOAD}$  is the load resistance.

## PREVENTING DAMAGE

Always ensure that the load resistance is 1200 Ohms or higher. If the load is capacitive, do not exceed 6.8 nF, and limit the operating frequency to the values indicated in the previous section.

This instrument does include protection circuitry to monitor the average and peak power being consumed in the output circuitry. However, if it is possible for the load to fail to a short circuit, it is recommended that the instrument be protected by adding at least 1200 Ohms of resistance in series with the device under test.

## DC OFFSET

In all modes, a DC offset may be added to the output signal. The DC offset can be set between -200V and +200V. The total output (amplitude + offset) can not exceed  $\pm 200V$ .



## -PANB BURST MODE OPTION

The -PANB option allows the generation of a burst of 1-500 cycles of sine, square, triangle, or pulse waveforms. This burst may be triggered by pressing a front-panel pushbutton, or by computer command.

 Beware that the instrument generates a burst output every time the pulse count (N) is changed (e.g., when the pulse:count command is sent, or when the pulse count is adjusted from the front panel).

### LOCAL MODE

The number of waveform cycle in each burst can be controlled from the front panel. The display normally shows “N=xxx” (xxx may range from 0 to 500), where N is the number of cycles in each burst.

When N=0, the instrument generates the output signal continuously – that is, the burst mode is disabled.

When N>0, the instrument is in burst mode. A burst may be triggered by pressing the “SINGLE PULSE” pushbutton.

A burst is also triggered any time that the value of the pulse count (N) is changed. For instance, when the ADJUST knob is rotated when the pulse count menu is displayed, a burst will be generated each time N increments or decrements. If this triggering is undesirable, set the amplitude to zero before adjusting the pulse count, and return the amplitude to the desired value after the pulse count is set properly.

### REMOTE MODE

When controlling the instrument from the GPIB or RS-232 ports, the burst mode is controlled using the “pulse:count” command.

Sending “pulse:count 0” disables the burst mode. That is, the instrument generates the output signal continuously.

Sending “pulse:count xxx”, where xxx is a number between 1 and 500, triggers a burst with xxx cycles of the output waveform.

The front-panel “SINGLE PULSE” pushbutton remains active in the remote mode. Pressing the “SINGLE PULSE” pushbutton after a “pulse:count” command will generate a burst, using the most recent pulse count setting.

## SYNC OUTPUT

In non-bursted operation, a 100 ns wide SYNC pulse is generated for each waveform cycle. This behaviour changes for burst mode operation. In this mode, a single SYNC pulse is generated for each burst, rather than each waveform cycle. The SYNC pulse width is equal to the duration of the burst. This simplifies the triggering of oscilloscopes.

The delay feature is disabled for pulse waveforms in the burst mode.

## OPERATIONAL CHECK

This section describes a sequence to confirm the basic operation of the instrument. It should be performed after receiving the instrument. It is a useful learning exercise as well.

Before proceeding with this procedure, finish reading this instruction manual thoroughly. Then read the “Local Control” section of the “Programming Manual for -B Instruments” thoroughly. The “Local Control” section describes the front panel controls used in this operational check - in particular, the MOVE, CHANGE, and ADJUST controls.

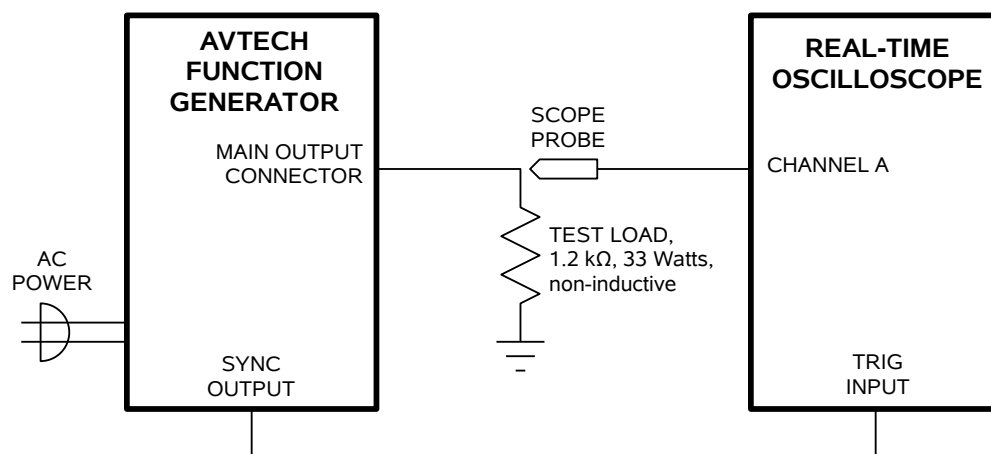

*Basic Test Arrangement*

1. Connect a non-inductive 1.2 kΩ, 33W test load between the OUT connector and ground. (Note: wirewound resistors are very inductive. Avoid them. Factory tests are conducted using eight fan-cooled 10 kΩ Ohm, 2W Ohmite OY-series resistors (model OY103K) connected in parallel. See [www.ohmite.com](http://www.ohmite.com) for information on OY resistors. These resistors may be purchased readily at [www.digikey.com](http://www.digikey.com).) If desired, a higher-resistance, lower-power load may be used to simplify the test. The required load power rating for a given resistance is  $40000 / R_{LOAD}$ , where  $R_{LOAD}$  is in Ohms.

Confirm that the oscilloscope and the test load are rated for  $\pm 200$  Volt operation.

2. Connect a cable from the SYNC connector to the TRIG input of an oscilloscope. Set the oscilloscope to trigger externally.
3. Connect an oscilloscope probe to the load. On the oscilloscope, set the vertical scale to 100 V/div, and the horizontal scale to 20 us/div.
4. Turn on the AV-153AH-B. The main menu will appear on the LCD.

5. To set the AV-153AH-B to trigger from the internal clock at a PRF of 30 kHz:
  - a) The arrow pointer should be pointing at the frequency menu item. If it is not, press the MOVE button until it is.
  - b) Press the CHANGE button. The frequency submenu will appear. Rotate the ADJUST knob until the frequency is set at 30 kHz.
  - c) Press CHANGE to return to the main menu.
6. To set the waveshape to a sinusoid:
  - a) Press the MOVE button until the arrow pointer is pointing at the shape menu item.
  - b) Press the CHANGE button. The delay submenu will appear.
  - c) Press MOVE until the arrow pointer is pointing at the "SINE" choice.
  - d) Press CHANGE to return to the main menu.
7. At this point, nothing should appear on the oscilloscope.
8. To enable the output:
  - a) Press the MOVE button until the arrow pointer is pointing at the output menu item.
  - b) Press the CHANGE button. The output submenu will appear.
  - c) Press MOVE until the arrow pointer is pointing at the "ON" choice.
  - d) Press CHANGE to return to the main menu.
9. To change the output amplitude:
  - a) Press the MOVE button until the arrow pointer is pointing at the amplitude menu item.
  - b) Press the CHANGE button. The amplitude submenu will appear. Rotate the ADJUST knob until the amplitude is set at +200V.
  - c) Observe the oscilloscope. You should see a 30 kHz, 200V peak (400V peak-to-peak) sine wave.
  - d) Press CHANGE to return to the main menu.

This completes the operational check.

## PROGRAMMING YOUR PULSE GENERATOR

### KEY PROGRAMMING COMMANDS

The “Programming Manual for -B Instruments” describes in detail how to connect the pulse generator to your computer, and the programming commands themselves. A large number of commands are available; however, normally you will only need a few of these. Here is a basic sample sequence of commands that might be sent to the instrument after power-up, using the internal trigger source:

*rst	(resets the instrument)
sour:func sin	(selects a sine wave output)
frequency 1000 Hz	(sets the frequency to 1000 Hz)
output on	(turns on the output)
volt 50	(sets the amplitude to 50 V)
volt:low -100	(sets the offset to +10 V)

To generate a pulse output, use:

*rst	(resets the instrument)
sour:func pulse	(selects a unipolar pulse output)
frequency 1000 Hz	(sets the frequency to 1000 Hz)
pulse:width 10 us	(sets the pulse width to 10 us)
pulse:delay 1 us	(sets the delay to 1 us)
output on	(turns on the output)
volt 50	(sets the amplitude to 50 V)
volt:low -100	(sets the offset to -100 V)

To amplify an external signal, use:

*rst	(resets the instrument)
sour:func amp	(enables the amplifier mode)
output on	(turns on the output)
volt 150	(sets the gain to $150 / 2 = 75$ )
volt:low -100	(sets the offset to -100 V)

To generate a burst of sine wave cycles (requires -PANB option), use:

*rst	(resets the instrument)
sour:func sin	(selects a sine wave output)
frequency 1000 Hz	(sets the frequency to 1000 Hz)
pulse:count 7	(disables continuous output mode – no burst though, because the amplitude is zero)

output on	(turns on the output)
volt 150	(sets the amplitude to 150 V)
pulse:count 7	(generates a burst of 7 sine wave cycles)

These commands will satisfy 90% of your programming needs.

## ALL PROGRAMMING COMMANDS

For more advanced programmers, a complete list of the available commands is given below. These commands are described in detail in the “Programming Manual for -B Instruments”. (Note: this manual also includes some commands that are not implemented in this instrument. They can be ignored.)

<u>Keyword</u>	<u>Parameter</u>	<u>Notes</u>
OUTPut:		
:[STATe]	<boolean value>	
:PROTection		
:TRIPped?		[query only]
[SOURce]:		
:FREQuency		
[:CW   FIXed]	<numeric value>	
:FUNCTion		
:[SHAPe]	AMPLify   PULSe   SINusoid   SQUare   TRIangle	
:PULSe		
:PERiod	<numeric value>	
:WIDTh	<numeric value>   IN	
:DELay	<numeric value>	
:COUNT	<numeric value>	[units with burst mode option only]
:VOLTage		
[:LEVel]		
[:IMMediate]		
[:AMPLitude]	<numeric value>	
:LOW	<numeric value>	
:PROTection		
:TRIPped?		[query only]
STATUS:		
:OPERation		
:[EVENT]?		[query only, always returns "0"]
:CONDition?		[query only, always returns "0"]
:ENABle	<numeric value>	[implemented but not useful]
:QUEStionable		
:[EVENT]?		[query only, always returns "0"]
:CONDition?		[query only, always returns "0"]
:ENABle	<numeric value>	[implemented but not useful]
SYSTem:		
:COMMunicate		
:GPIB		
:ADDReSS	<numeric value>	
:SERial		
:CONTRol		
:RTS	ON   IBFull   RFR	
:[RECeive]		
:BAUD	1200   2400   4800   9600   19200   38400   57600   115200	
:ERRor		
:[NEXT]?		[query only]
:COUNT?		[query only]
:VERSion?		[query only]
TRIGger:		
:SOURce	INTernal   EXTernal   MANual   HOLD   IMMEDIATE	
*CLS		[no query form]
*ESE	<numeric value>	



*ESR?		[query only]
*IDN?		[query only]
*OPC		
*SAV	0   1   2   3	[no query form]
*RCL	0   1   2   3	[no query form]
*RST		[no query form]
*SRE	<numeric value>	
*STB?		[query only]
*TST?		[query only]
*WAI		[no query form]

## MECHANICAL INFORMATION

### TOP COVER REMOVAL

If necessary, the interior of the instrument may be accessed by removing the four Phillips screws on the top panel. With the four screws removed, the top cover may be slid back (and off).

 Always disconnect the power cord and allow the instrument to sit unpowered for 10 minutes before opening the instrument. This will allow any internal stored charge to discharge.

There are no user-adjustable internal circuits. For repairs other than fuse replacement, please contact Avtech (info@avtechpulse.com) to arrange for the instrument to be returned to the factory for repair. Service is to be performed solely by qualified service personnel.

 Caution: High voltages are present inside the instrument during normal operation. Do not operate the instrument with the cover removed.

### RACK MOUNTING

A rack mounting kit is available. The -R5 rack mount kit may be installed after first removing the one Phillips screw on the side panel adjacent to the front handle.

### ELECTROMAGNETIC INTERFERENCE

To prevent electromagnetic interference with other equipment, all used outputs should be connected to shielded loads using shielded coaxial cables. Unused outputs should be terminated with shielded coaxial terminators or with shielded coaxial dust caps, to prevent unintentional electromagnetic radiation. All cords and cables should be less than 3m in length.

## MAINTENANCE

### REGULAR MAINTENANCE

This instrument does not require any regular maintenance.

On occasion, one or more of the four rear-panel fuses may require replacement. All fuses can be accessed from the rear panel. See the “FUSES” section for details.

### CLEANING

If desired, the interior of the instrument may be cleaned using compressed air to dislodge any accumulated dust. (See the “TOP COVER REMOVAL” section for instructions on accessing the interior.) No other cleaning is recommended.

### TRIGGER DAMAGE

The rear-panel TRIG input, used in the external trigger mode, is protected by a diode clamping circuit. However, the protection circuit is not foolproof, and it is possible for a grossly excessive signal to damage the trigger circuitry on the main timing control board (the 4×10 inch board on the right side of the instrument).

The IC that is most likely to fail under these conditions is installed in a socket. It is a standard TTL IC in a 16-pin plastic DIP package, model 74F151 or equivalent.

If you suspect that this IC has been damaged, turn off the power and replace this IC. It may be replaced by a 74F151, 74LS151, 74ALS151, or 74HCT151.

## OTHER INFORMATION

### APPLICATION NOTES

Application notes are available on the Avtech web site, at <http://www.avtechpulse.com/appnote>.

### MANUAL FEEDBACK

Please report any errors or omissions in this manual, or suggestions for improvement, to [info@avtechpulse.com](mailto:info@avtechpulse.com). Thanks!

# WIRING DIAGRAMS

## WIRING OF AC POWER

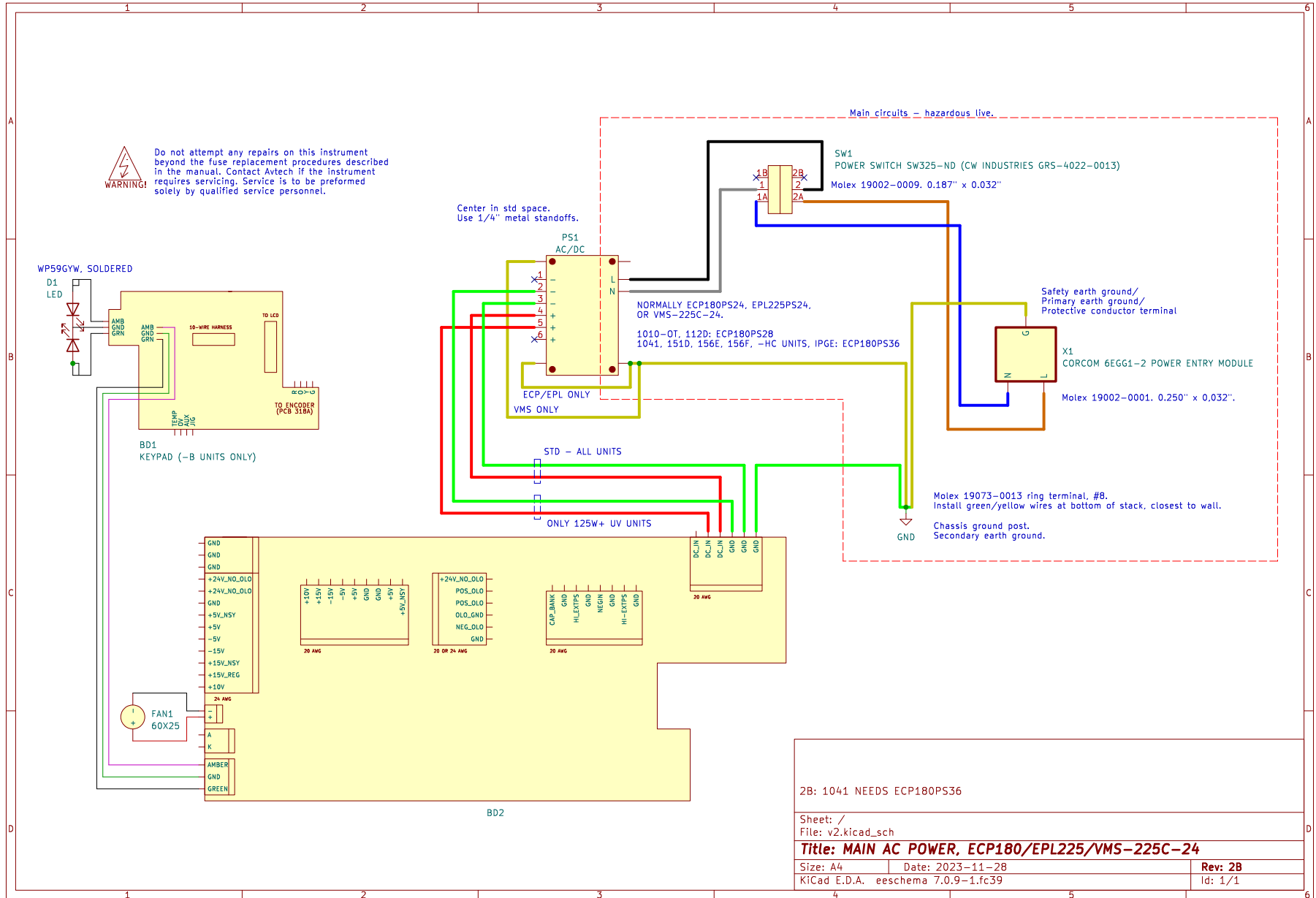

2B: 1041 NEEDS ECP180PS36

Sheet: /  
File: v2.kicad\_sch

**Title: MAIN AC POWER, ECP180/EPL225/VMS-225C-24**

Size: A4 | Date: 2023-11-28  
KiCad E.D.A. eeschema 7.0.9-1.fc39

Rev: 2B  
Id: 1/1

# WIRING OF DC POWER SUPPLIES

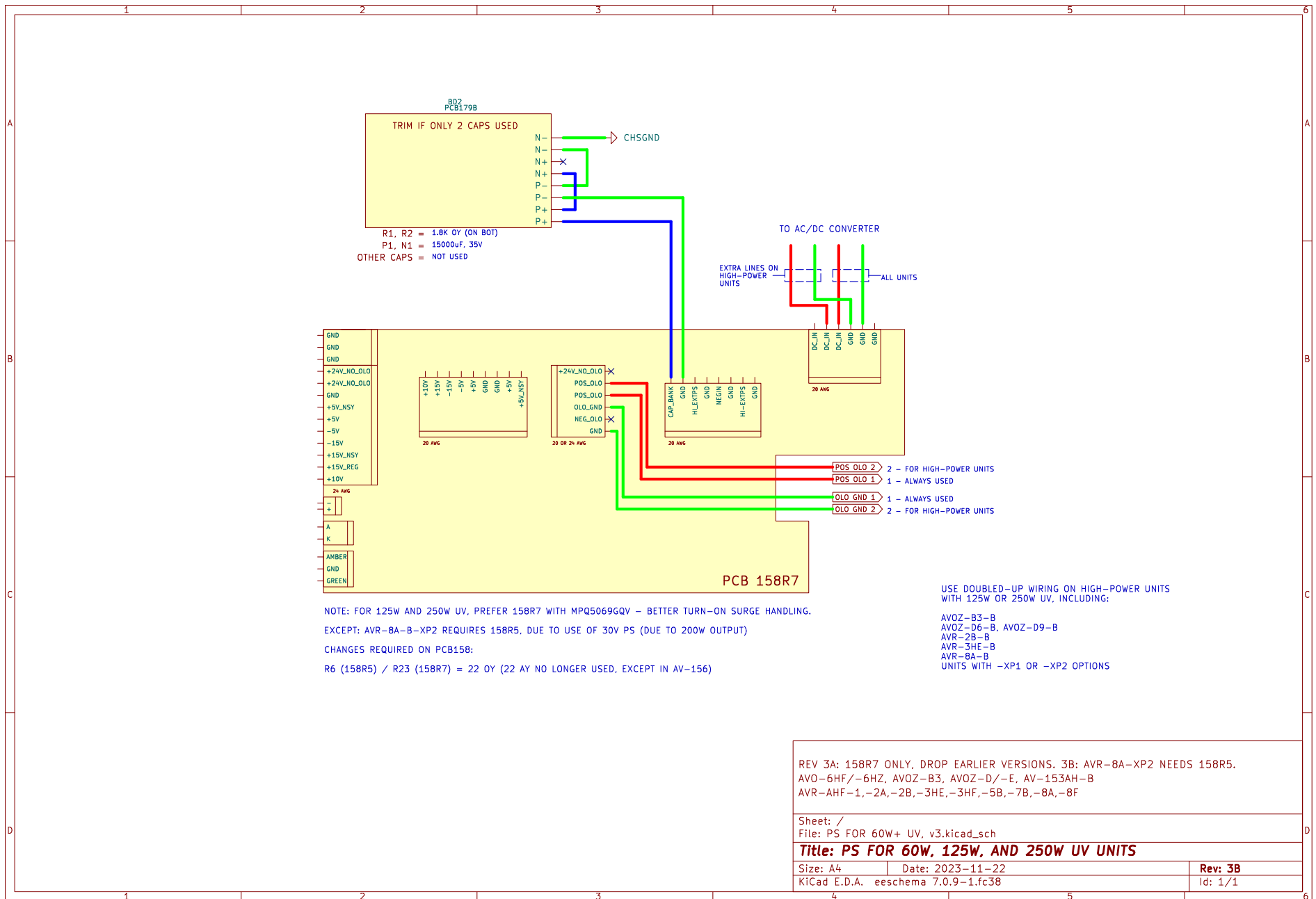

# WIRING OF HV POWER SUPPLIES

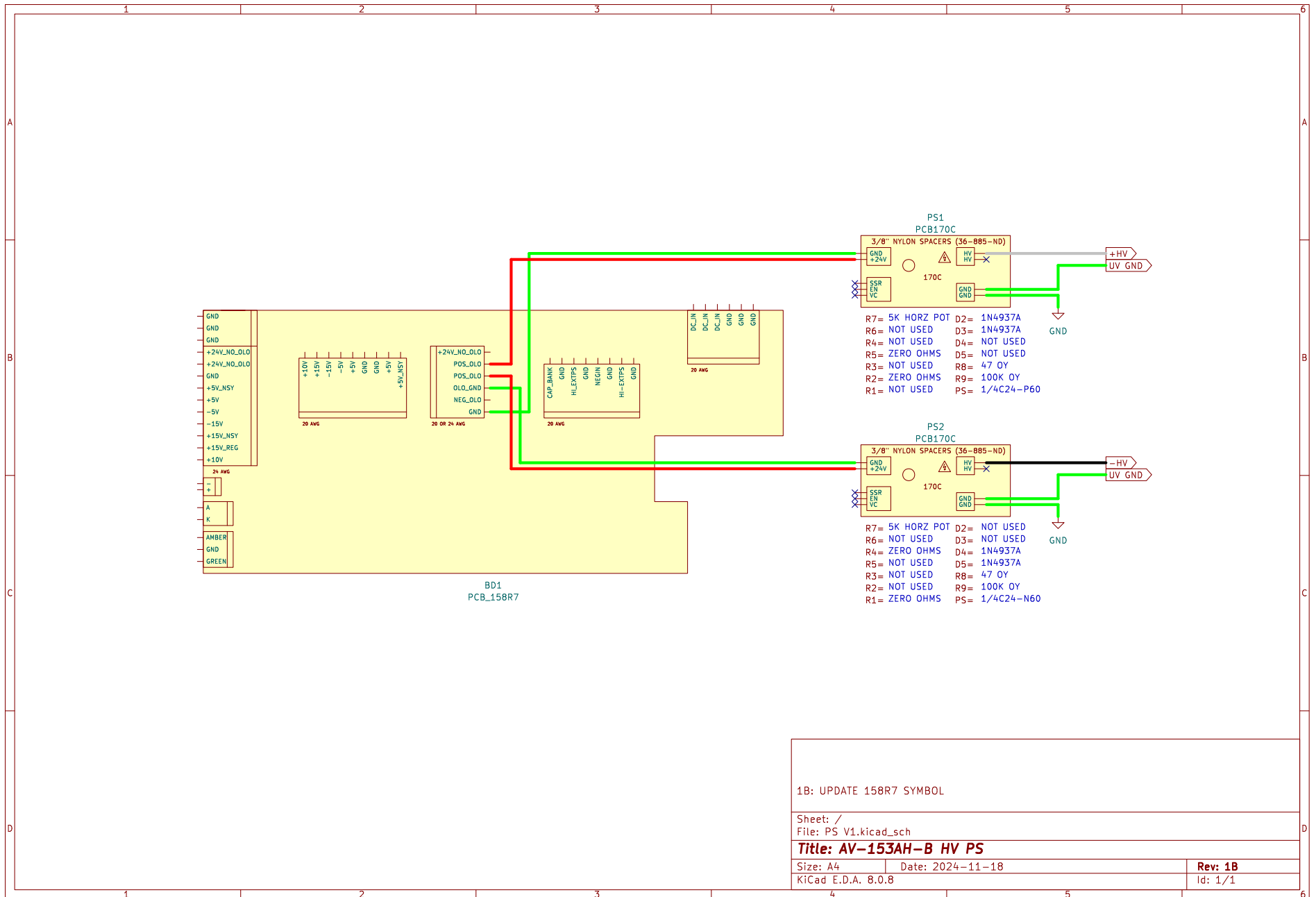

1B: UPDATE 158R7 SYMBOL

Sheet: /  
File: PS V1.kicad\_sch

**Title: AV-153AH-B HV PS**

Size: A4 Date: 2024-11-18  
KiCad E.D.A. 8.0.8

**Rev: 1B**  
Id: 1/1

# PCB 158R7 - LOW VOLTAGE POWER SUPPLY

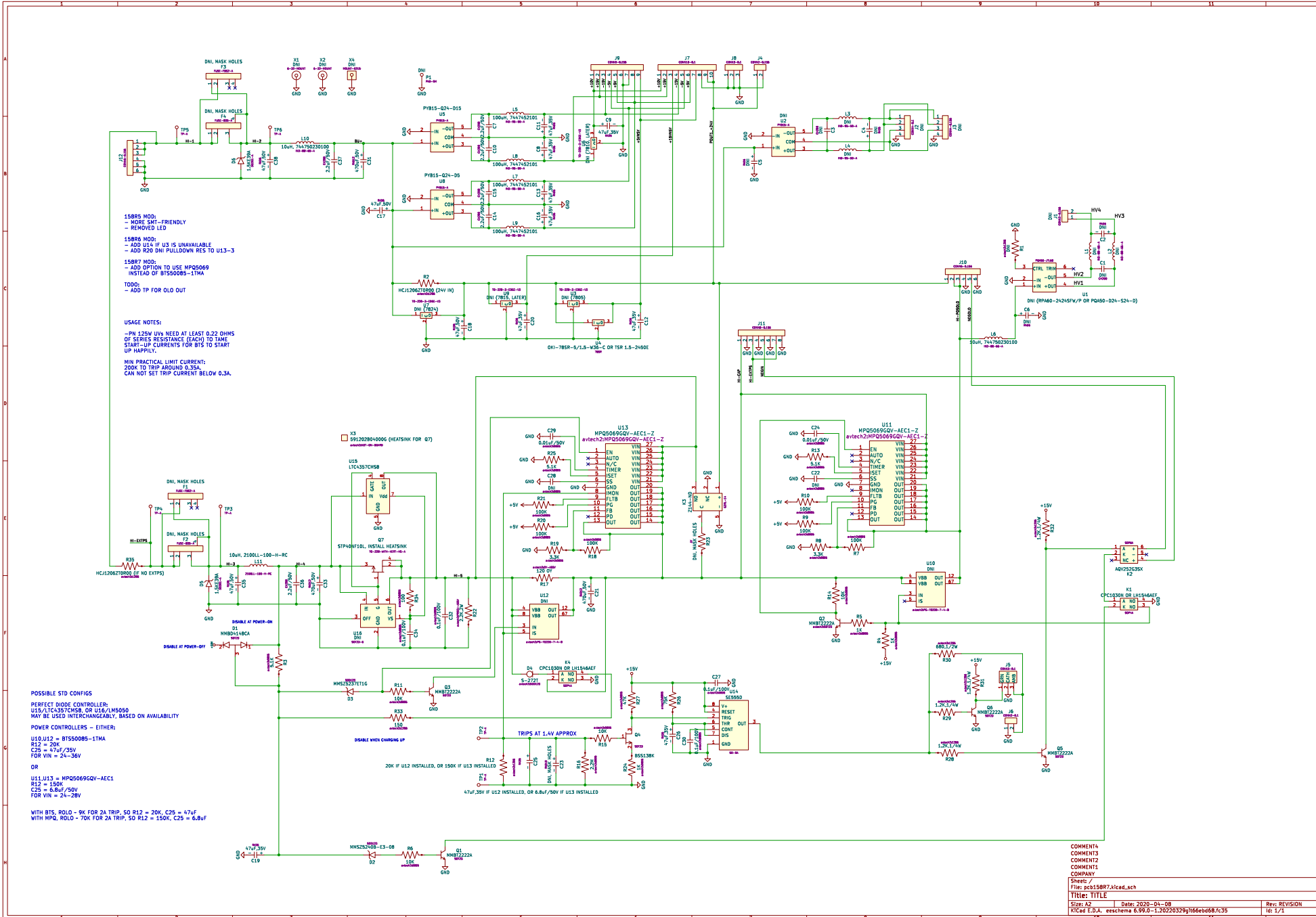

158R5 MOD:  
- NONE SMT-FRIENDLY  
- REMOVED LED

158R6 MOD:  
- ADD SCA IF U13 IS UNAVAILABLE  
- ADD R20 DNI PULLDOWN RES TO U13-3

158R7 MOD:  
- ADD OPTION TO USE WPD5069  
INSTEAD OF B15500B5-1TMA

TODO:  
- ADD TP FOR OLG OUT

USAGE NOTES:  
- IN 1.25V VIN NEED AT LEAST 0.22 OHMS  
OF SERIES RESISTANCE (EACH) TO TAME  
START-UP CURRENTS FOR BITS TO START  
UP HAPPILY.

MIN PRACTICAL LIMIT CURRENT:  
200K TO TRIP AROUND 0.35A.  
CAN NOT SET TRIP CURRENT BELOW 0.3A.

POSSIBLE STD CONFIGS

PERFECT DIODE CONTROLLER:  
U14=LTC437CM5B, OR U14=AMS5050  
MAY BE USED INTERCHANGEABLY, BASED ON AVAILABILITY

POWER CONTROLLERS - EITHER:  
U10,U12 = B15500B5-1TMA  
R12 = 20K  
C25 = 47uF/35V  
FOR VIN = 24-36V

OR  
U11,U13 = NPQ5069GQV-AEC1  
R12 = 150K  
C25 = 6.8uF/50V  
FOR VIN = 24-28V

WITH BITS, R0L0 - 9K FOR 2A TRIP, SO R12 = 20K, C25 = 47uF  
WITH NPN, R0L0 = 70K FOR 2A TRIP, SO R12 = 150K, C25 = 6.8uF



# PCB 170C - HIGH-VOLTAGE POWER SUPPLY

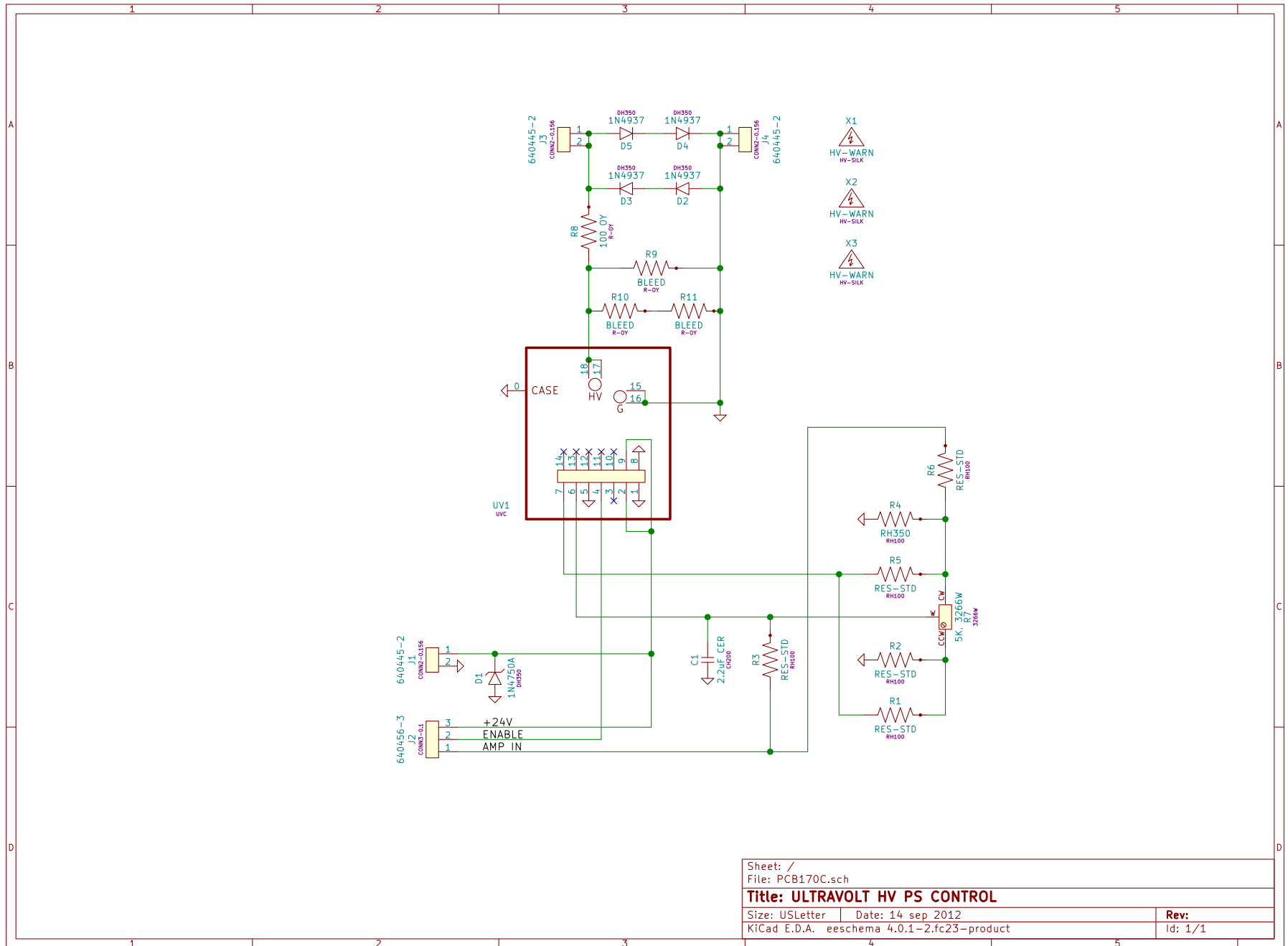

Sheet: /		File: PCB170C.sch	
<b>Title: ULTRAVOLT HV PS CONTROL</b>			
Size: USLetter	Date: 14 sep 2012	Rev:	
KiCad E.D.A. eeschema 4.0.1-2.fc23-product	Id: 1/1		

# PCB 155E - WAVEFORM GENERATOR, 1/4

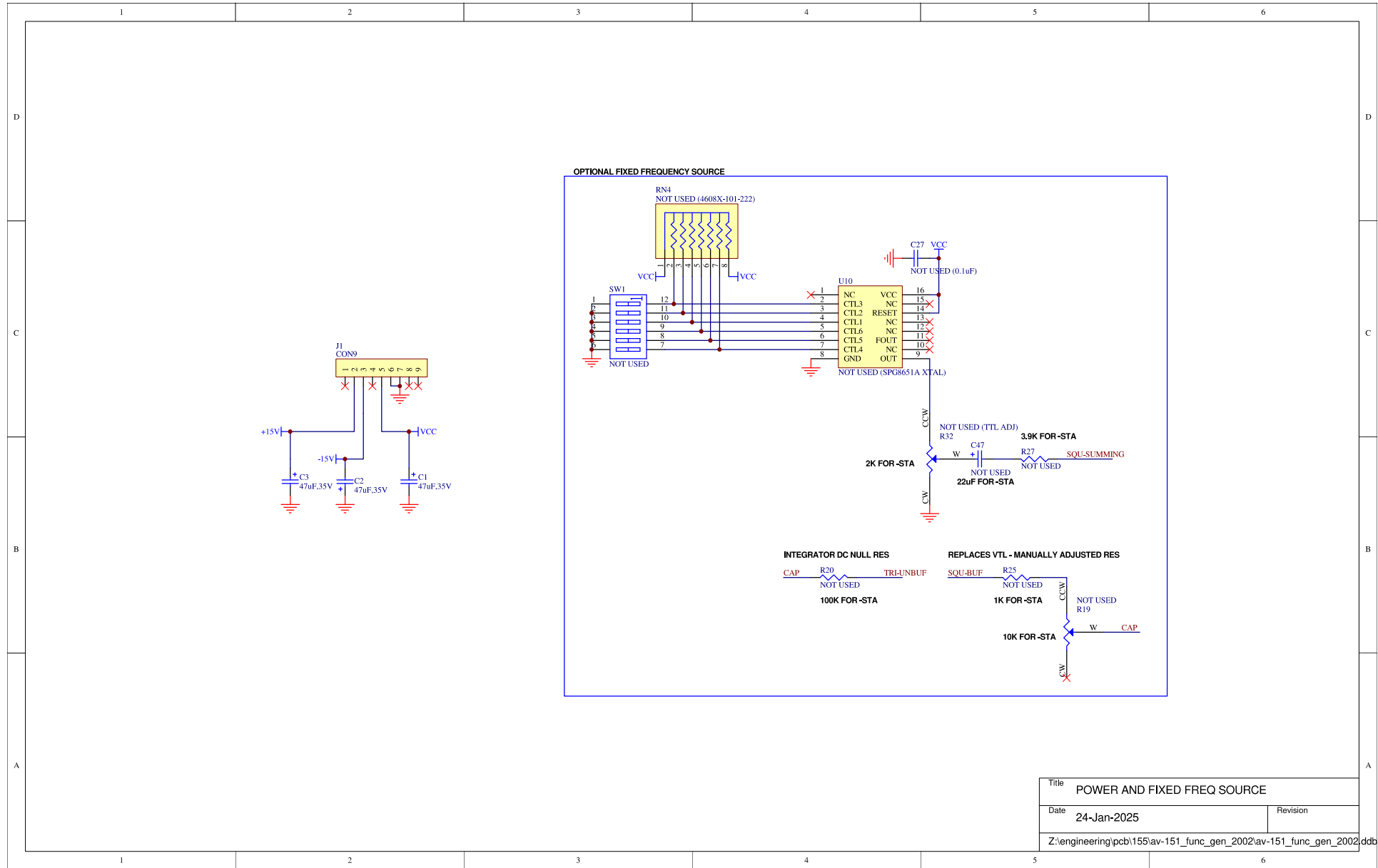

Title		POWER AND FIXED FREQ SOURCE	
Date	24-Jan-2025	Revision	
Z:\engineering\pcb\155\av-151_func_gen_2002\av-151_func_gen_2002.ddb			

# PCB 155E - WAVEFORM GENERATOR, 2/4

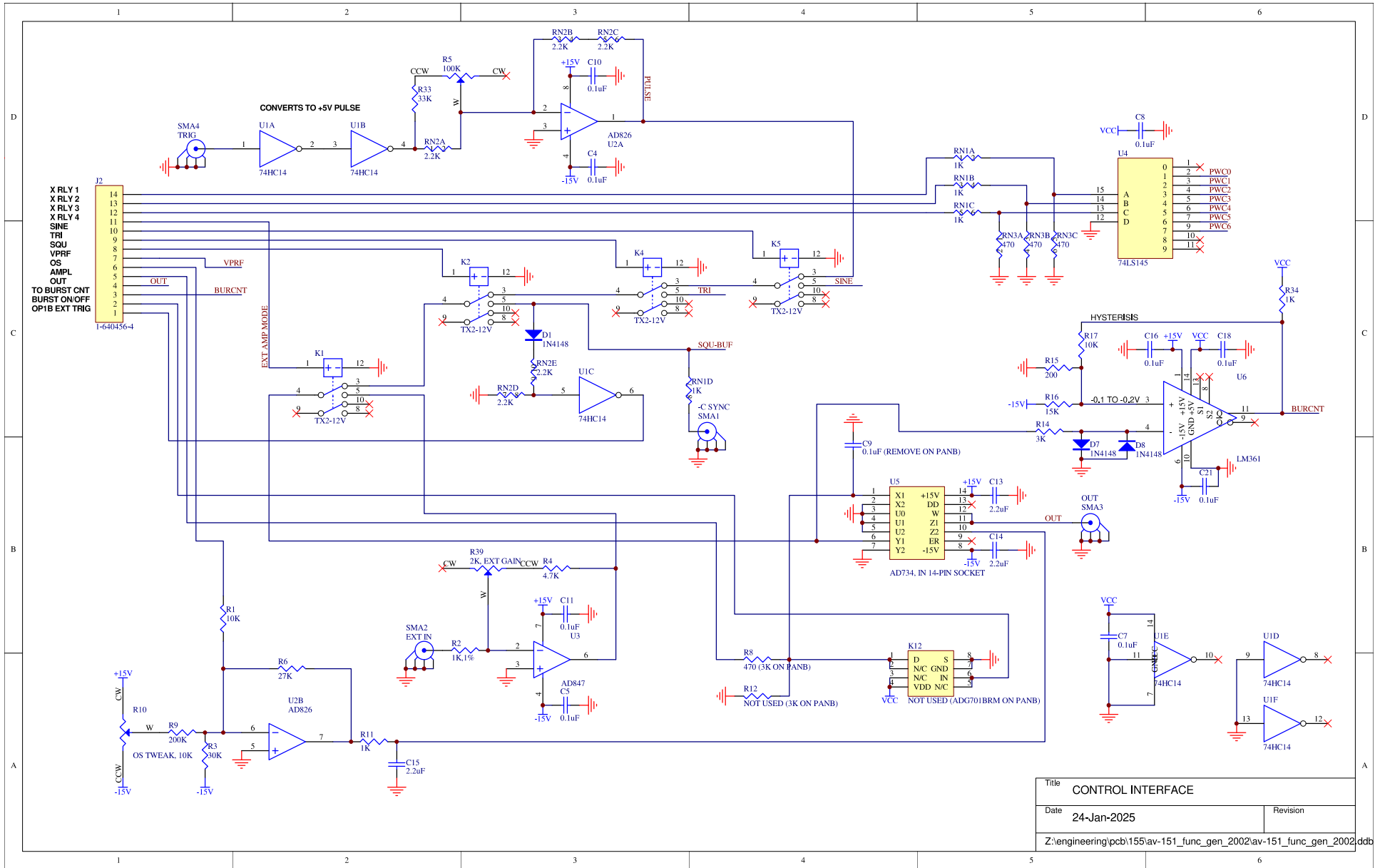

Title		CONTROL INTERFACE	
Date	24-Jan-2025	Revision	
Z:\engineering\pcb\155av-151_func_gen_2002\av-151_func_gen_2002.ddb			

# PCB 155E - WAVEFORM GENERATOR, 3/4

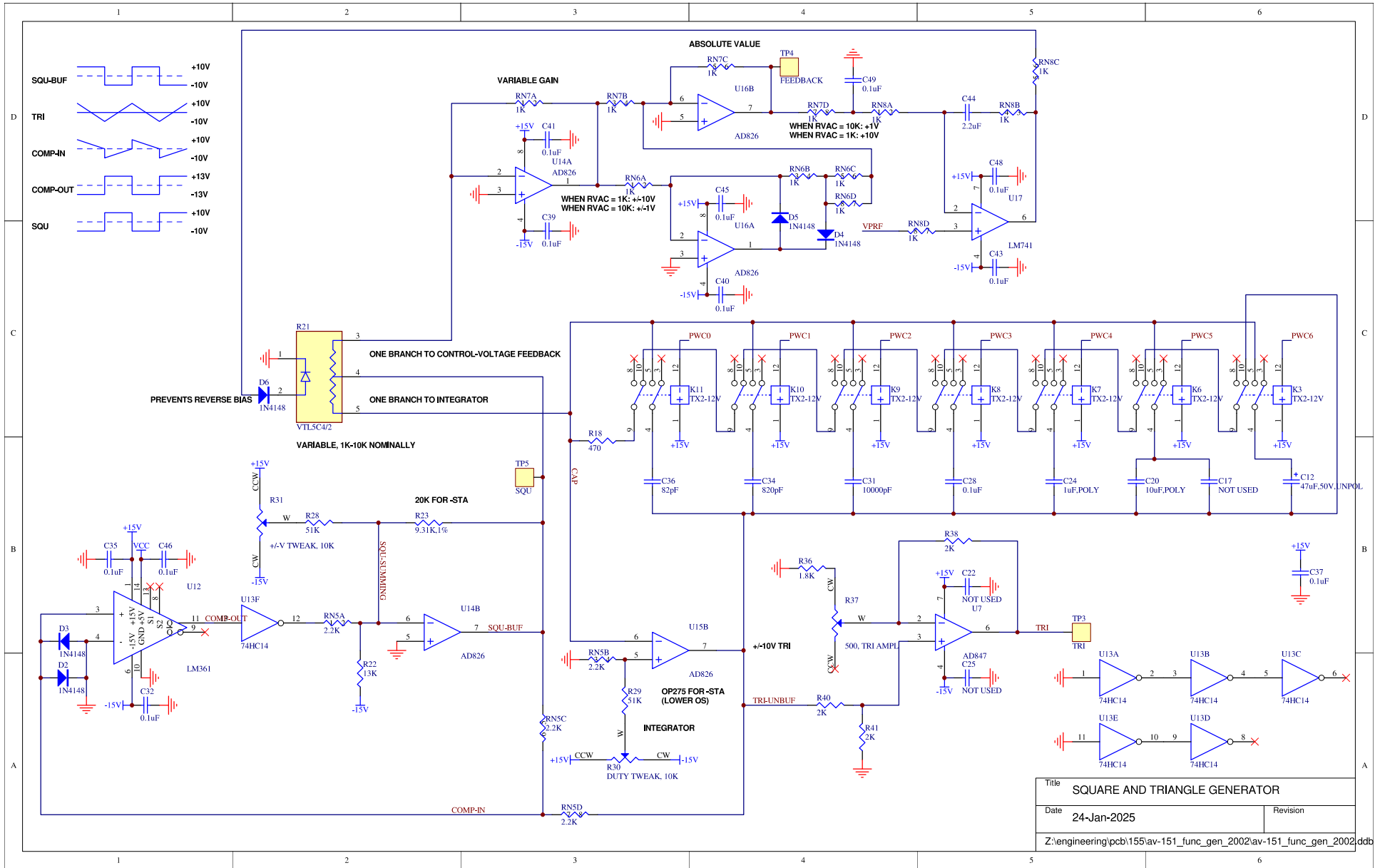

# PCB 155E - WAVEFORM GENERATOR, 4/4

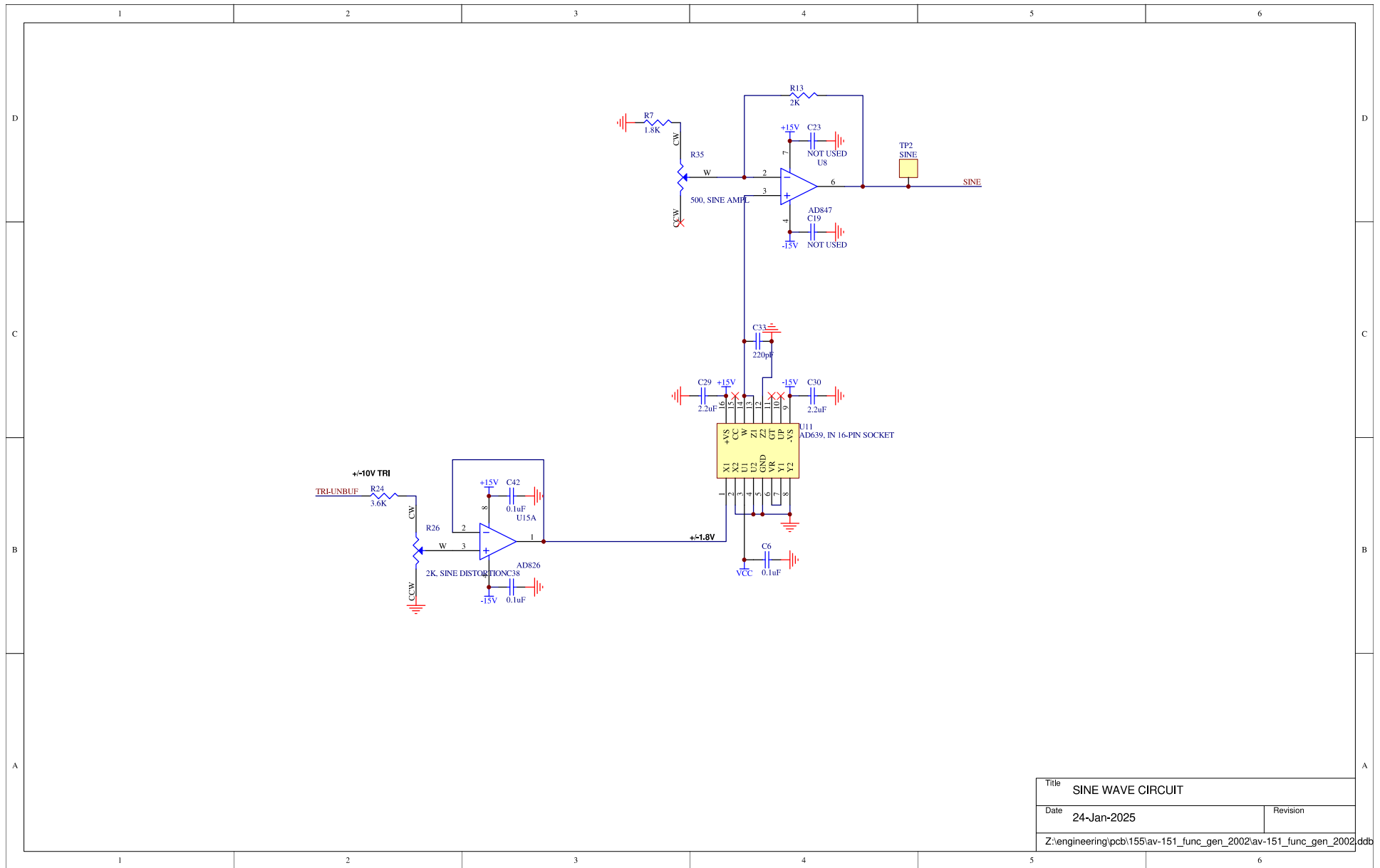

Title		SINE WAVE CIRCUIT	
Date	24-Jan-2025	Revision	
Z:\engineering\pcb\155\av-151_func_gen_2002\av-151_func_gen_2002.ddb			

# PCB 107E - BURST PANB OPTION,1/2

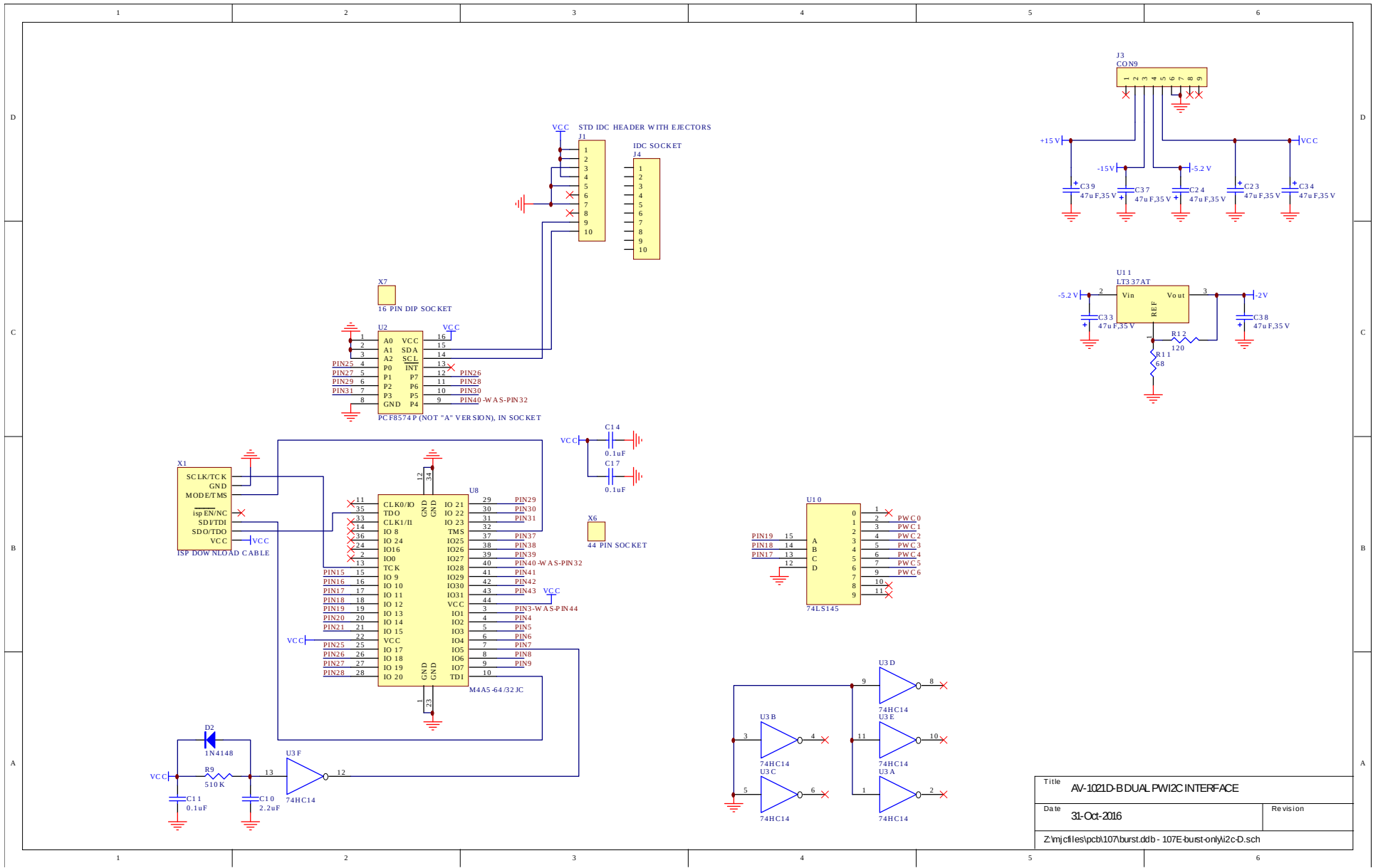

Title		AV-1021D-B DUAL PWI2C INTERFACE	
Date	31-Oct-2016	Revision	
Z:\mjcfiles\pcb\107\burst.dtb - 107E-burst-only\i2c-D.sch			

# PCB 107E - BURST PANB OPTION, 2/2

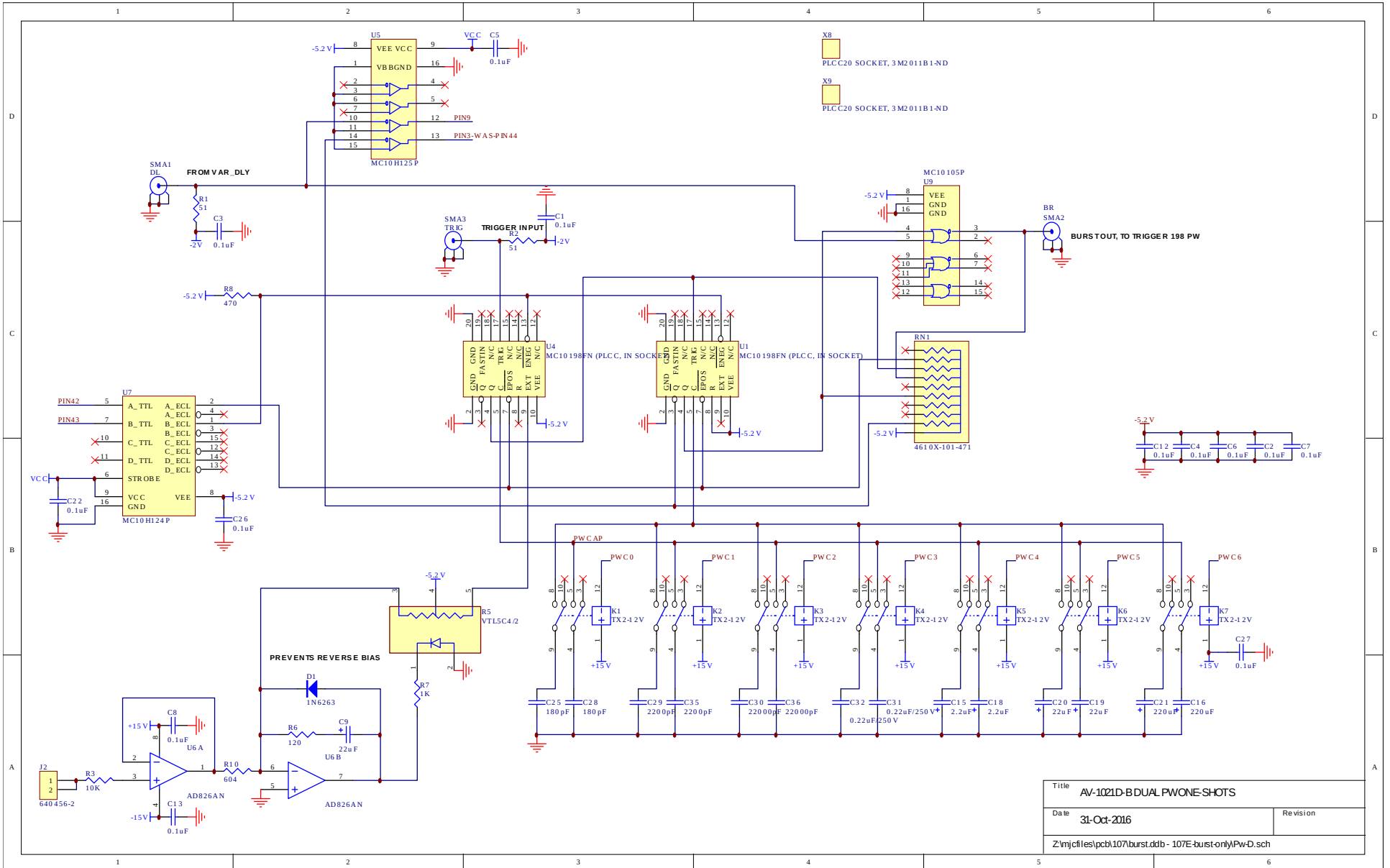

# PCB 335C - SYNC BUFFER

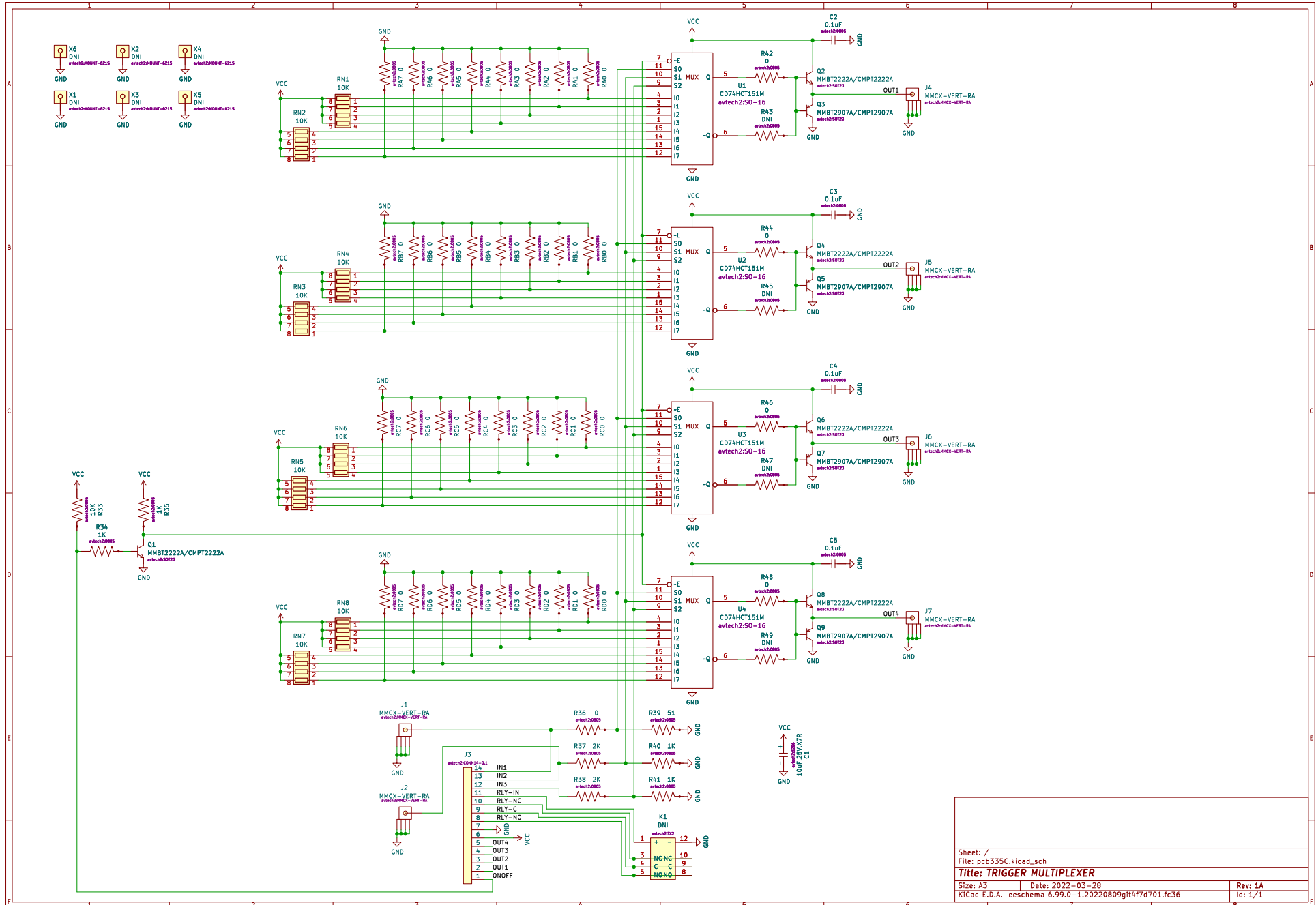

Sheet: /		File: pcb335C.kicad_sch	
<b>Title: TRIGGER MULTIPLEXER</b>			
Size: A3	Date: 2022-03-28	Rev: 1A	
KiCad E.D.A. eeschema 6.99.0-1.20220809git4f7d701.fc36		Id: 1/1	



# PCB 104H - KEYPAD / DISPLAY BOARD

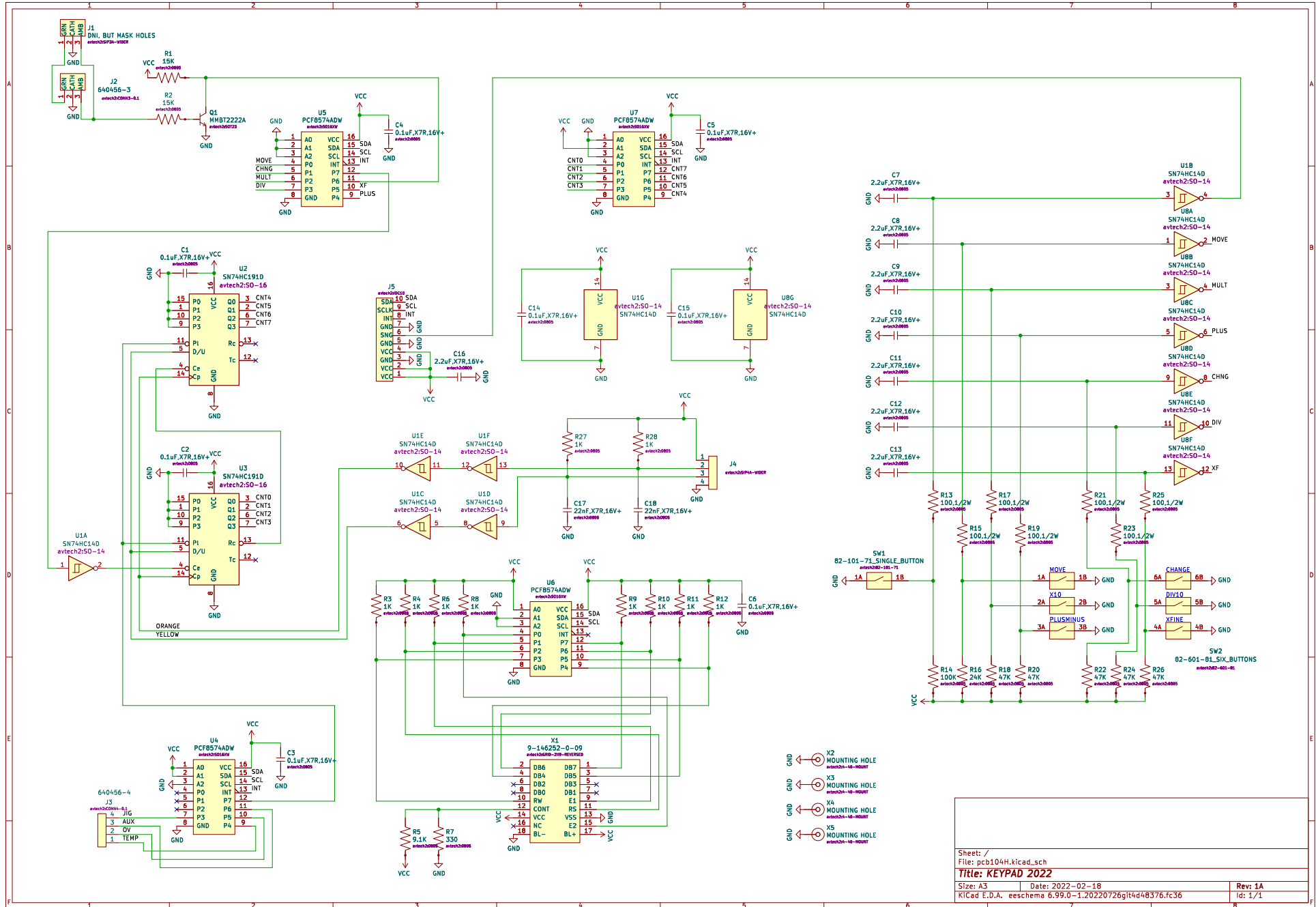

Sheet: /	File: pcb104H.kicad_sch
Title: KEYPAD 2022	
Size: A3	Date: 2022-02-18
KiCad E.D.A. eeschema 6.99.0-1.20220726git4d48376.fc36	Id: 1/1

# PCB 295G - MAIN CONTROL BOARD, 1 OF 13, TOP-LEVEL

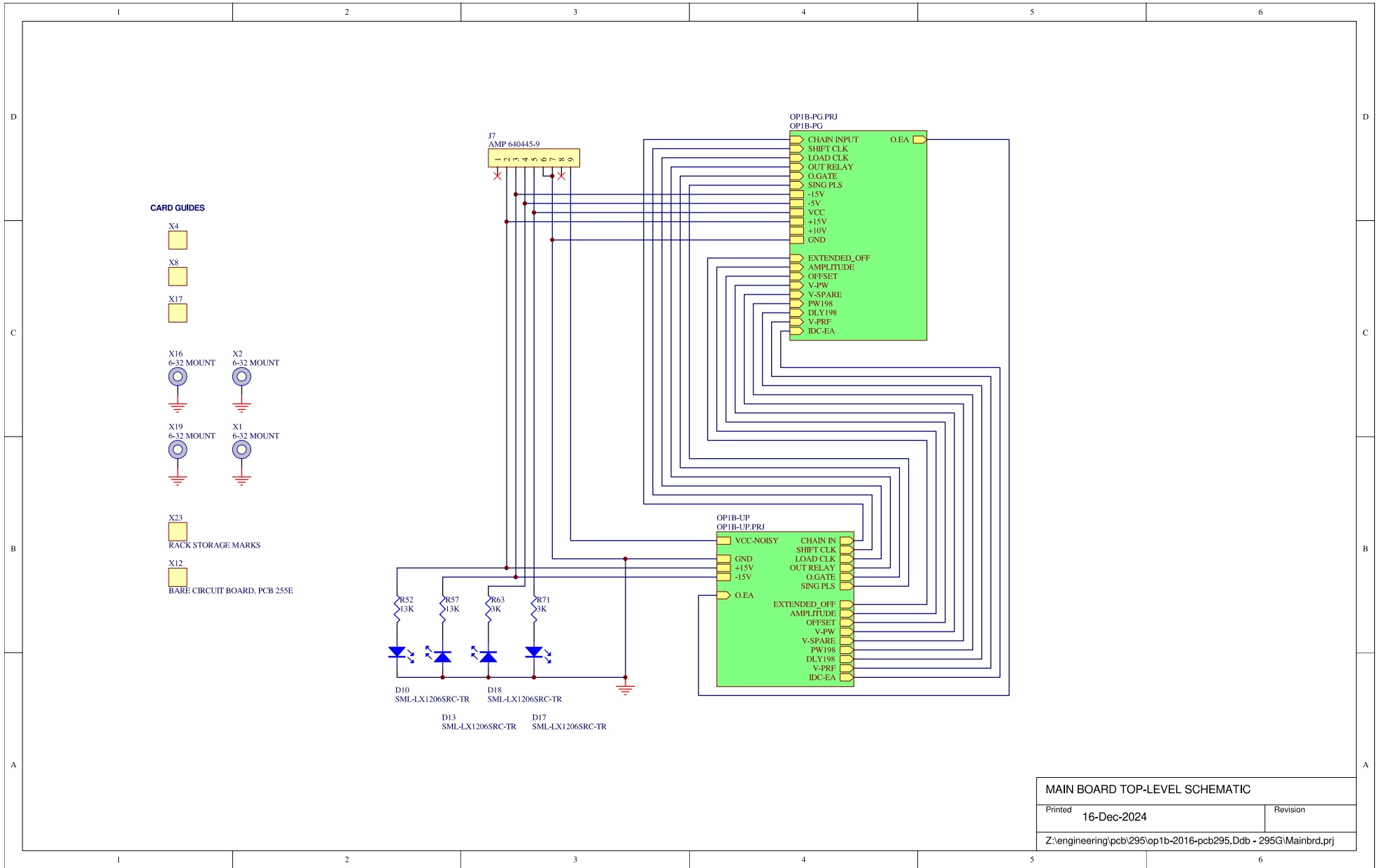

MAIN BOARD TOP-LEVEL SCHEMATIC	
Printed 16-Dec-2024	Revision
Z:\engineering\pcb\295\op1b-2016-pcb295.Ddb - 295G>Mainbrd.prj	

# PCB 295G - MAIN CONTROL BOARD, 2 OF 13, MICROCONTROLLER TOP-LEVEL

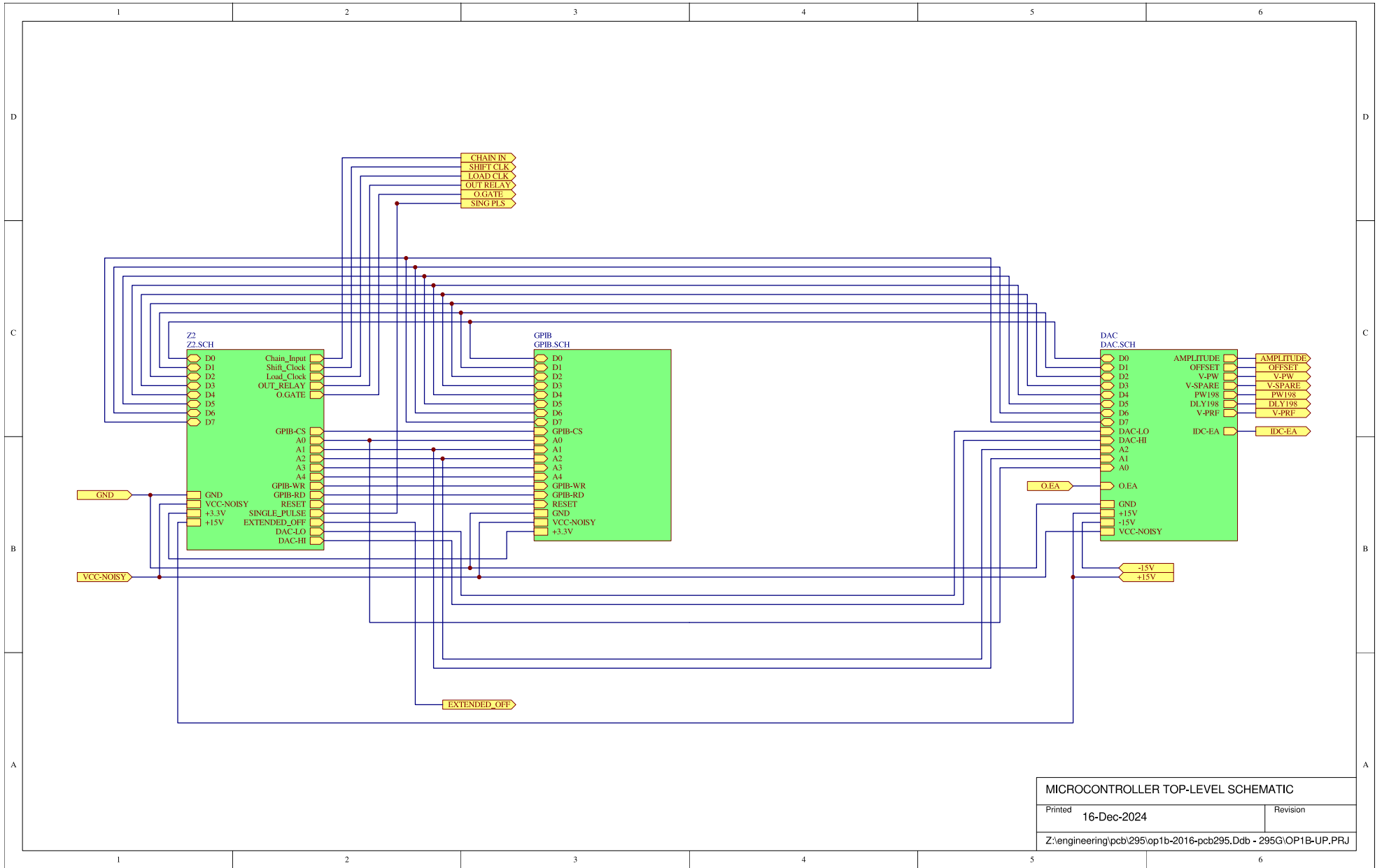

MICROCONTROLLER TOP-LEVEL SCHEMATIC	
Printed	16-Dec-2024
Revision	
Z:\engineering\pcb\295\op1b-2016-pcb295.Ddb - 295G\OP1B-UP.PRJ	

# PCB 295G - MAIN CONTROL BOARD, 3 OF 13, EMBEDDED CONTROLLER

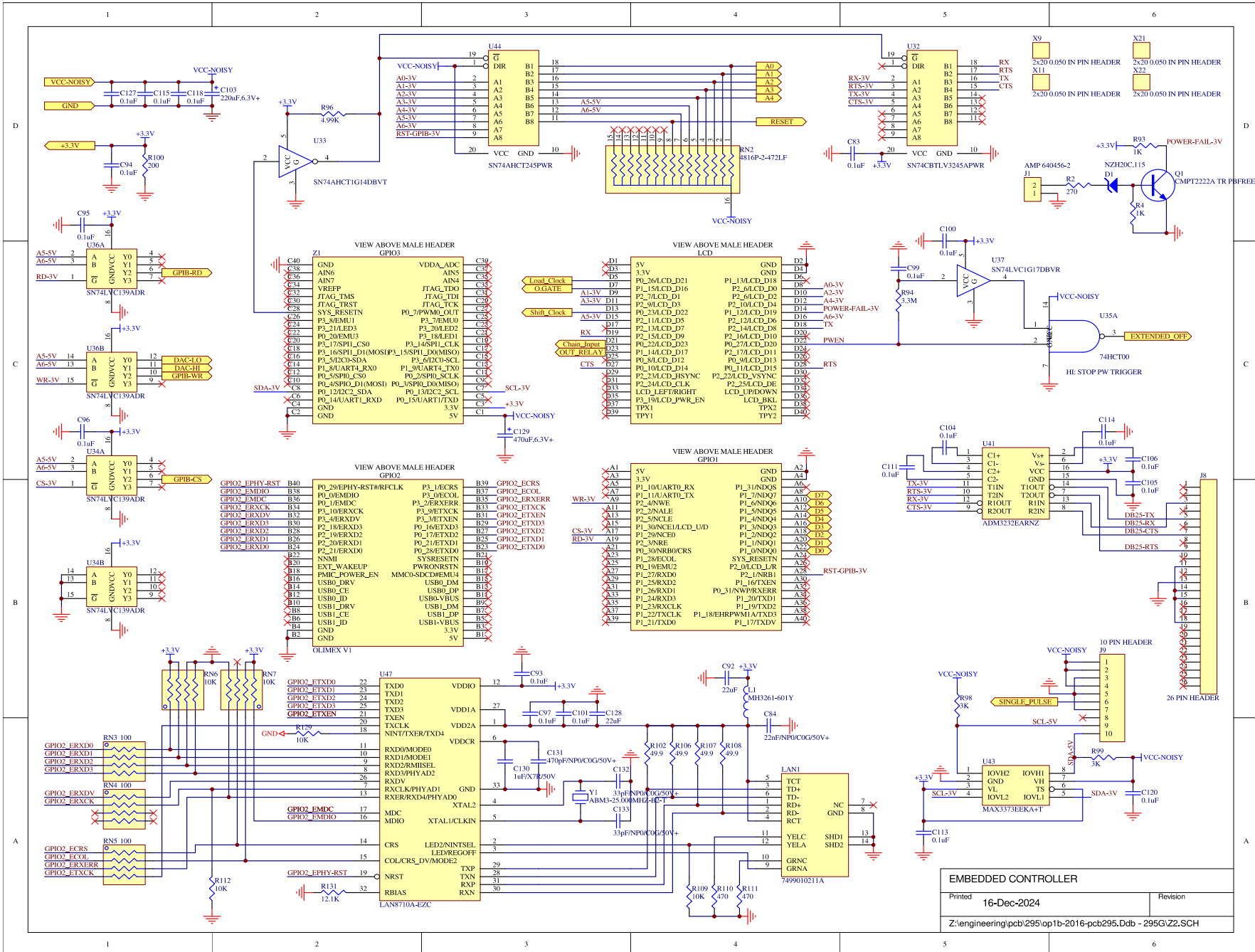

# PCB 295G - MAIN CONTROL BOARD, 4 OF 13, GPIB INTERFACE

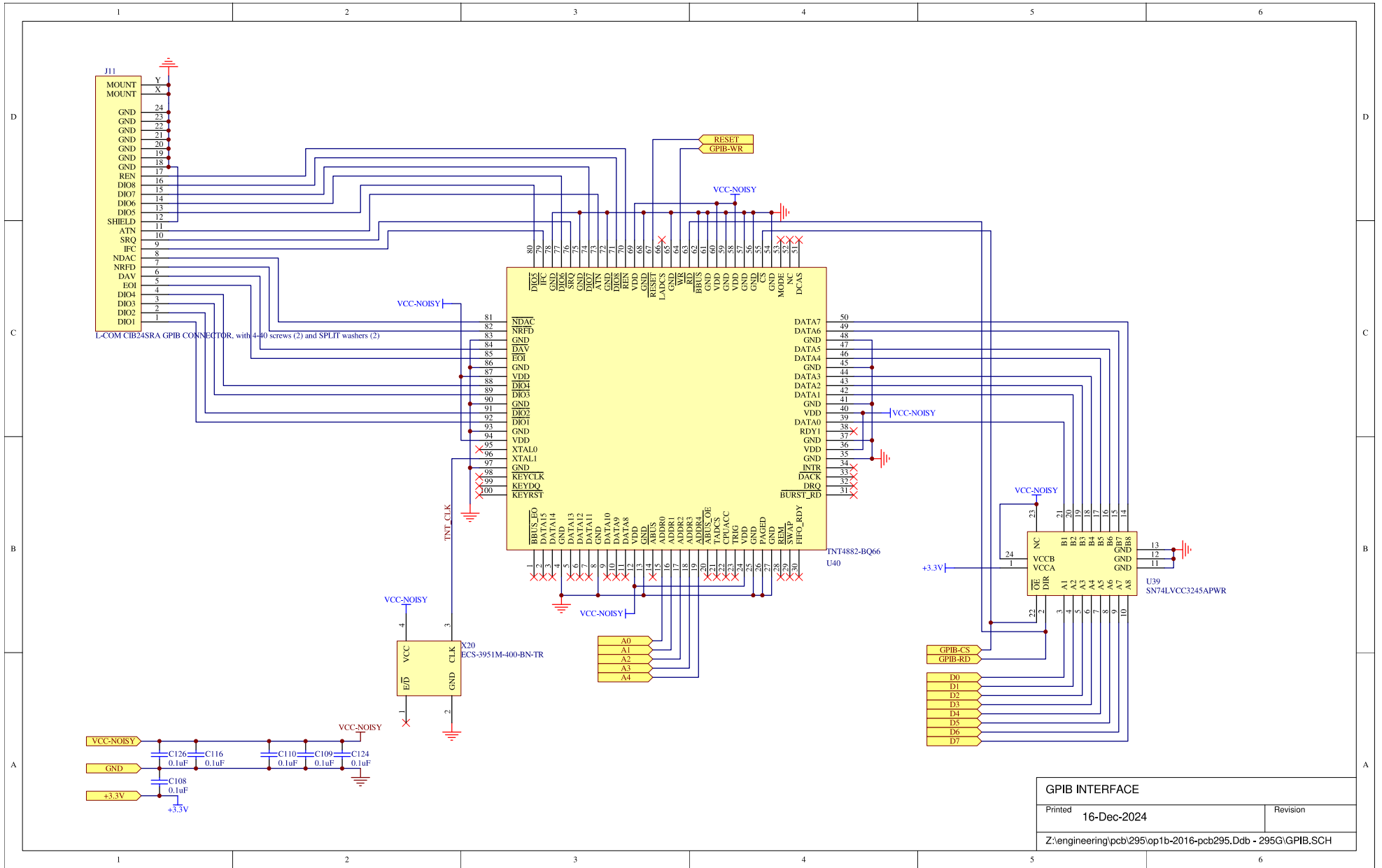

GPIB INTERFACE	
Printed	Revision
16-Dec-2024	
Z:\engineering\pcb\295\op1b-2016-pcb295.Ddb - 295G\GPIB.SCH	

# PCB 295G - MAIN CONTROL BOARD, 5 OF 13, DACs

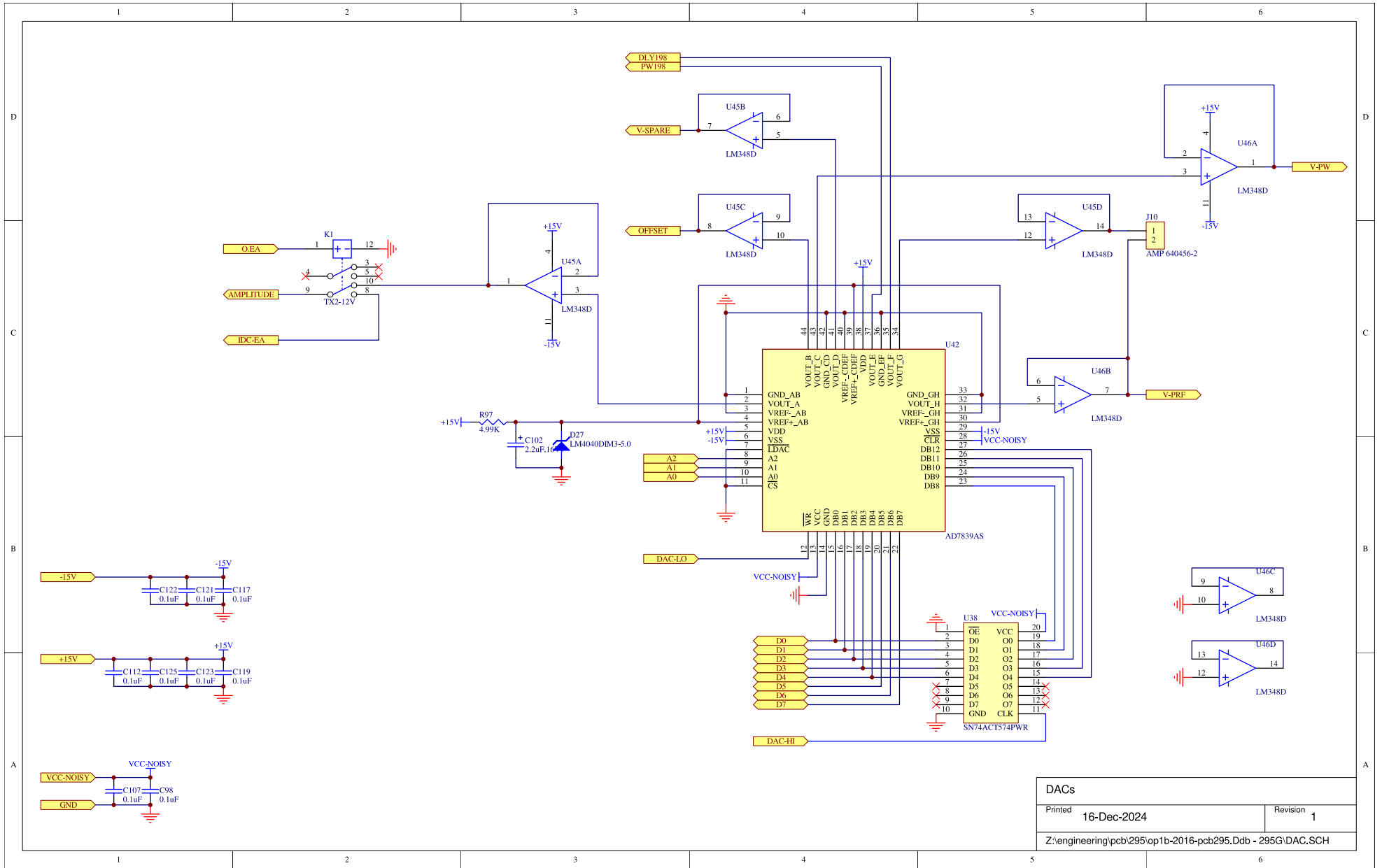

# PCB 295G - MAIN CONTROL BOARD, 6 OF 13, TIMING TOP-LEVEL

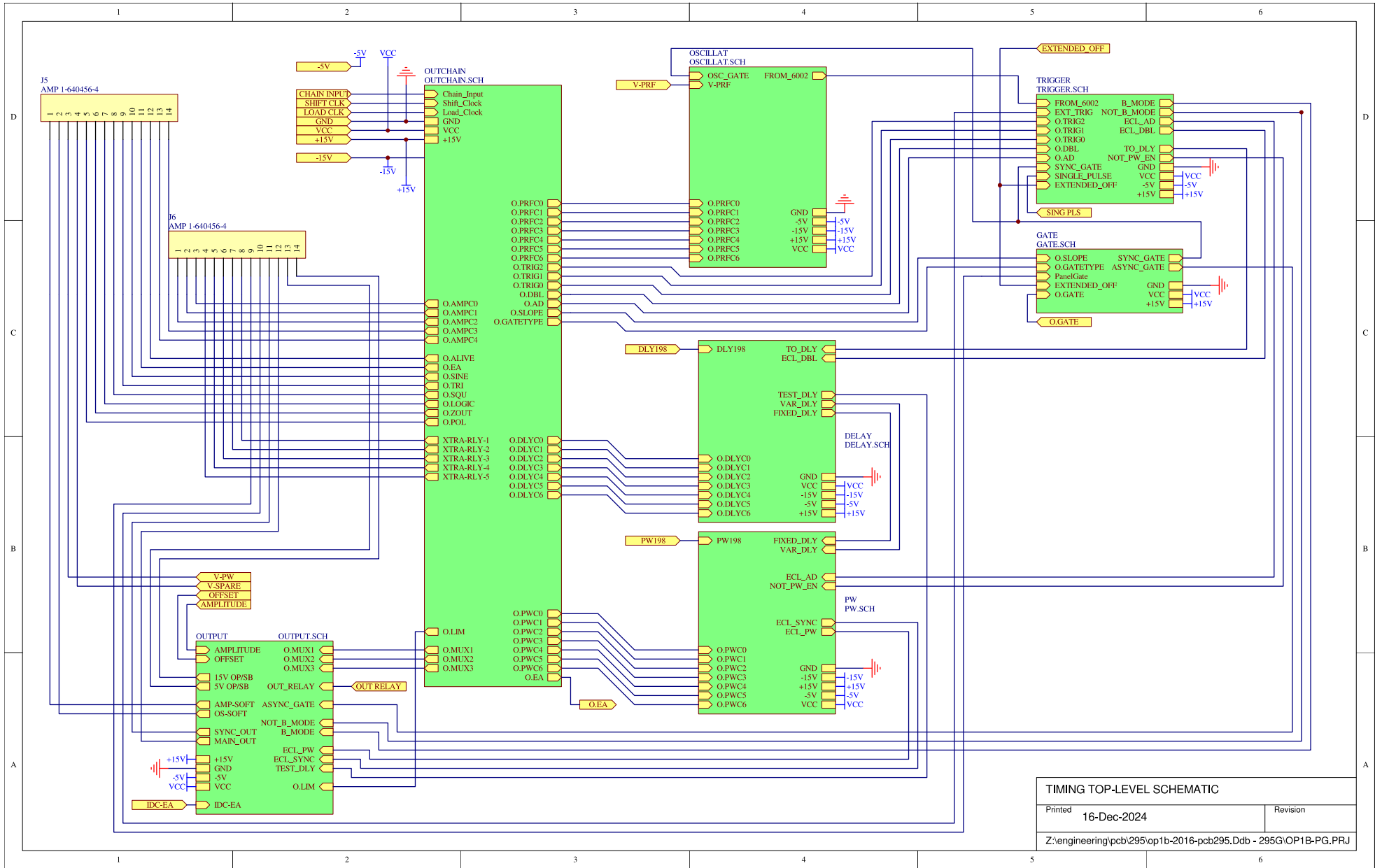

TIMING TOP-LEVEL SCHEMATIC	
Printed	Revision
16-Dec-2024	
Z:\engineering\pcb\295\op1b-2016-pcb295.Ddb - 295G\OP1B-PG_P RJ	

# PCB 295G - MAIN CONTROL BOARD, 7 OF 13, GATE CIRCUIT

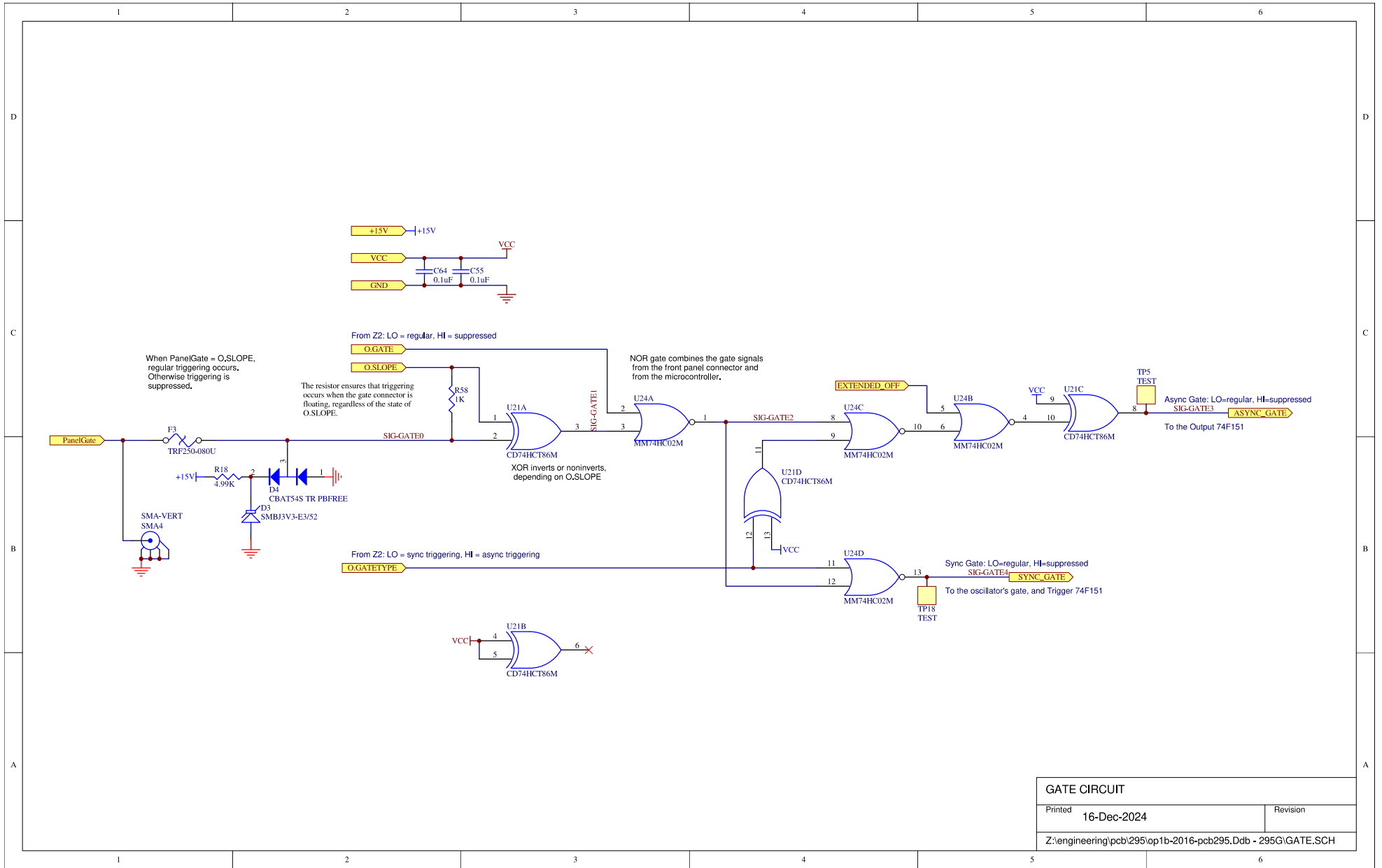



# PCB 295G - MAIN CONTROL BOARD, 8 OF 13, OSCILLATOR

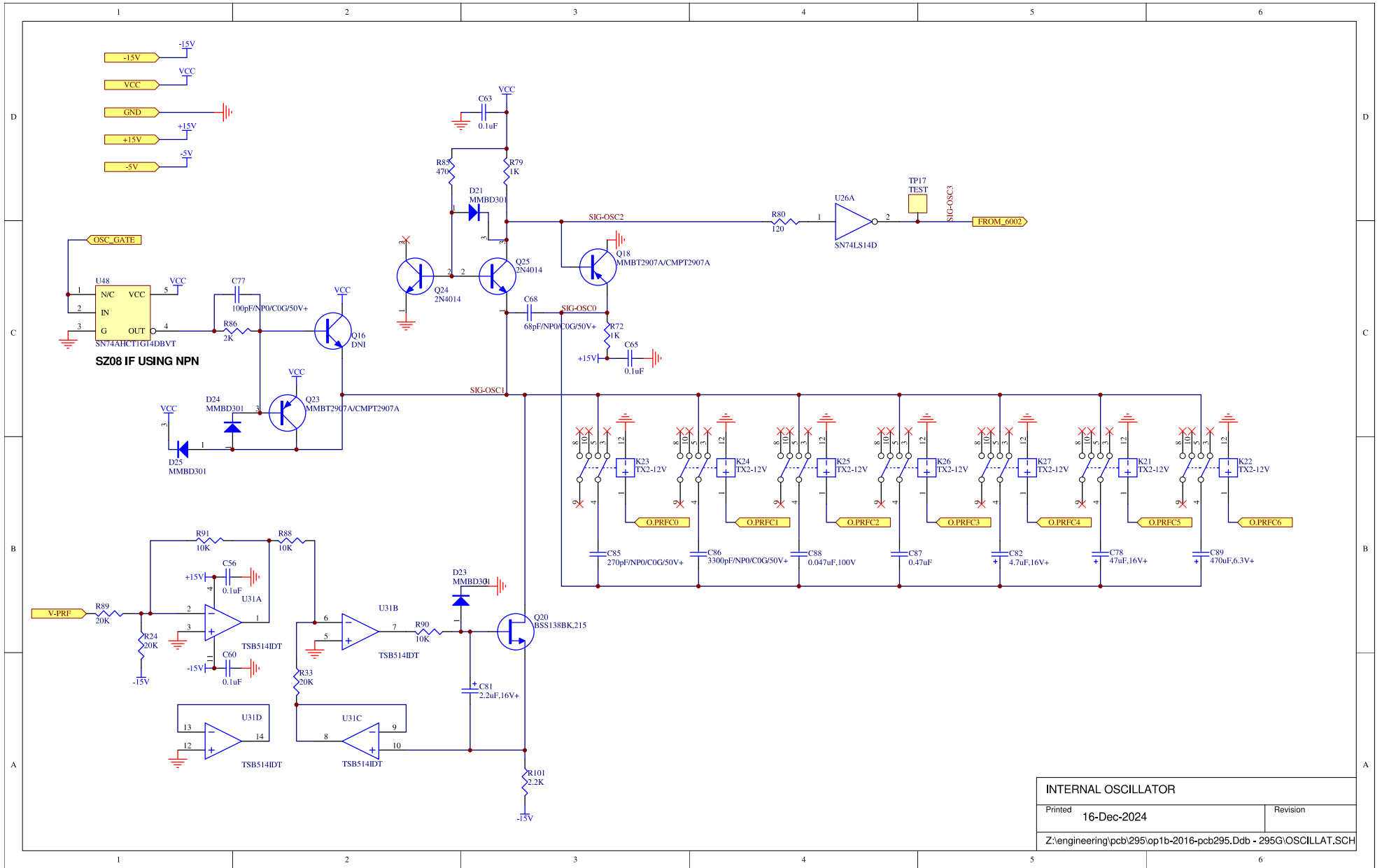

# PCB 295G - MAIN CONTROL BOARD, 9 OF 13, TTL OUTPUTS

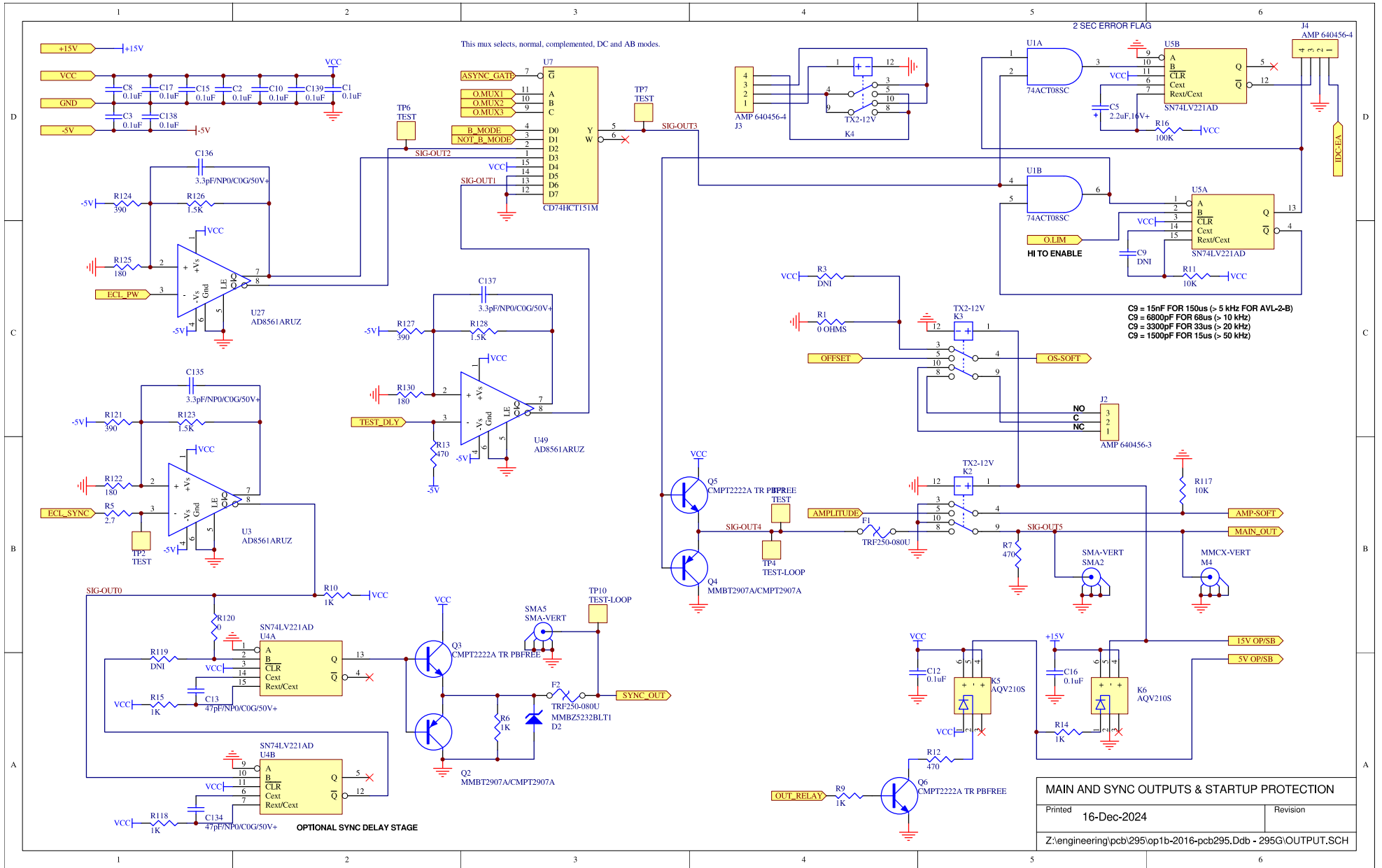

# PCB 295G - MAIN CONTROL BOARD, 10 OF 13, DELAY CIRCUITS

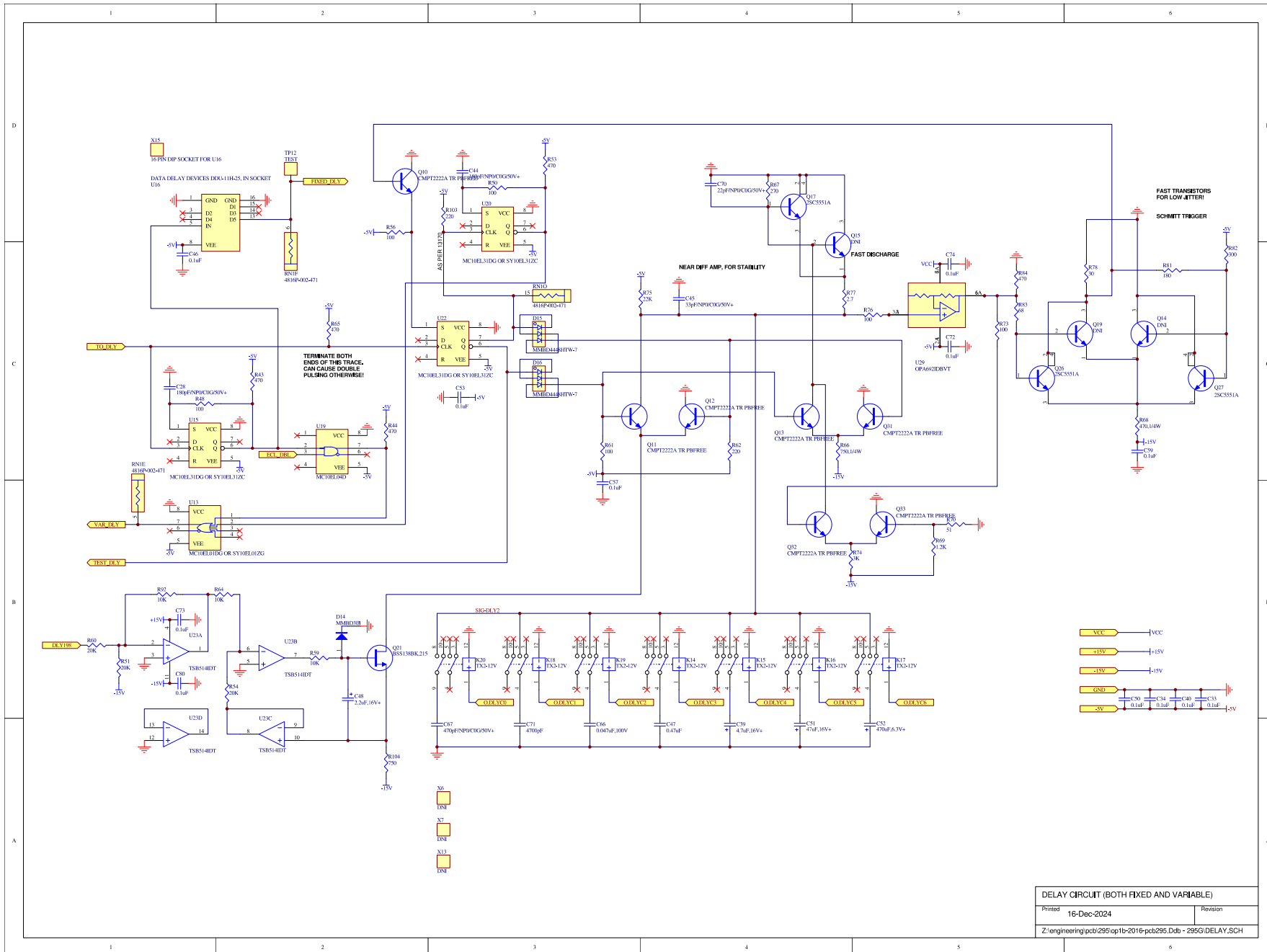

# PCB 295G - MAIN CONTROL BOARD, 11 OF 13, PULSE WIDTH CIRCUIT

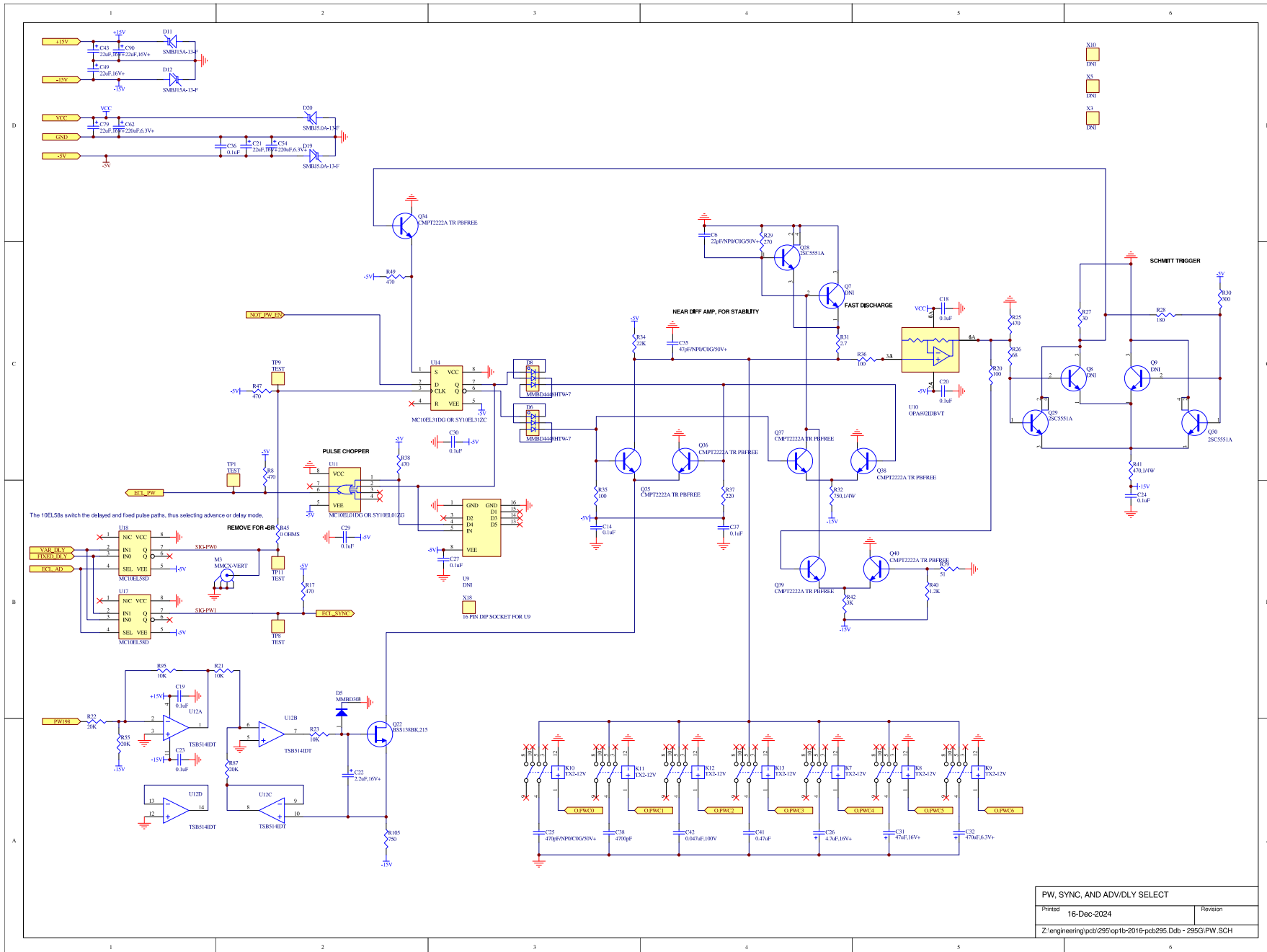

PW, SYNC, AND ADV/DLY SELECT		
Printed	16-Dec-2024	Revision
Z:\engineering\pcb\295\optb-2016-pcb295.Dxb - 295G.PW.SCH		

# PCB 295G - MAIN CONTROL BOARD, 12 OF 13, TRIGGER SELECT

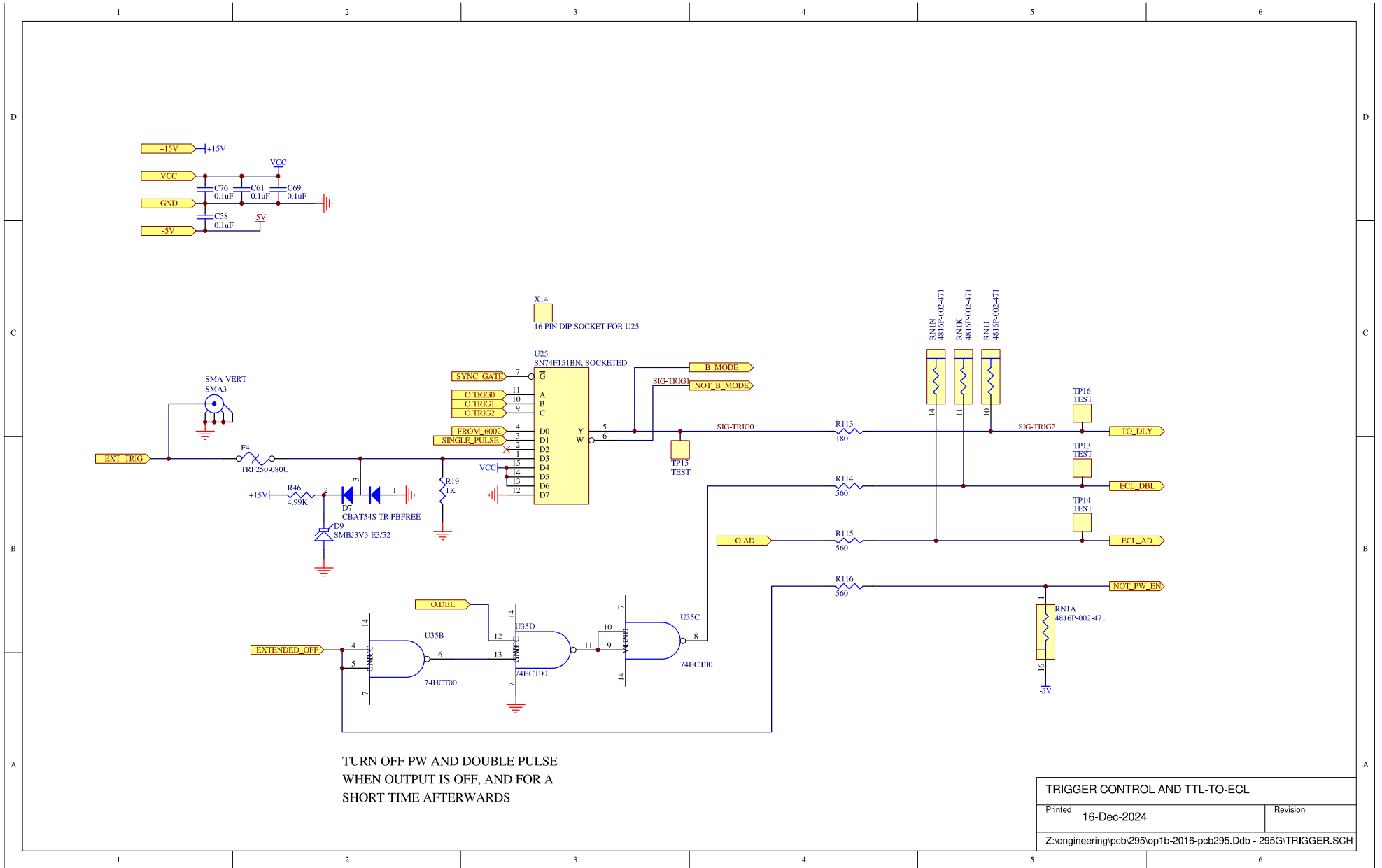

# PCB 295G - MAIN CONTROL BOARD, 13 OF 13, SHIFT REGISTERS

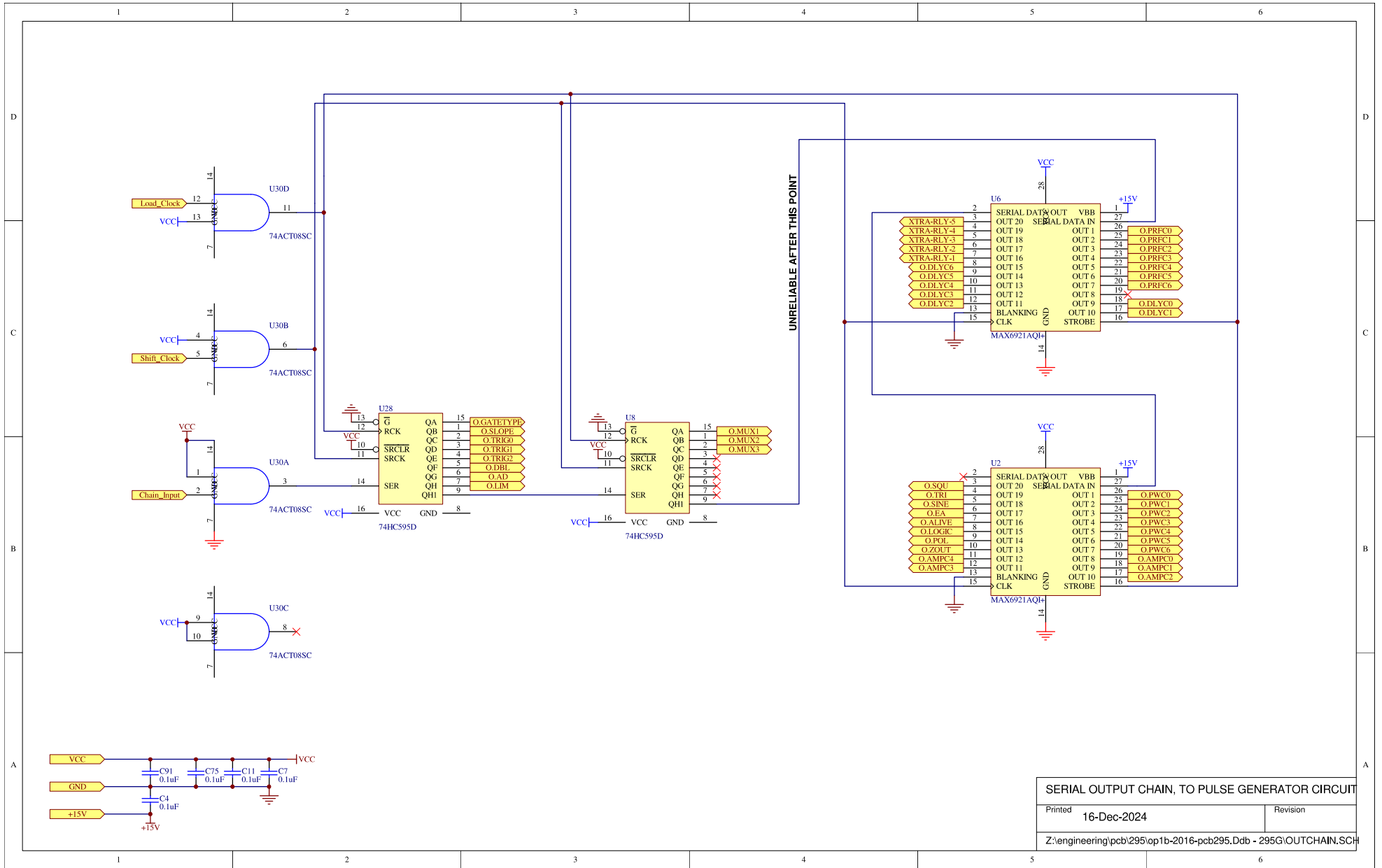

# MAIN WIRING

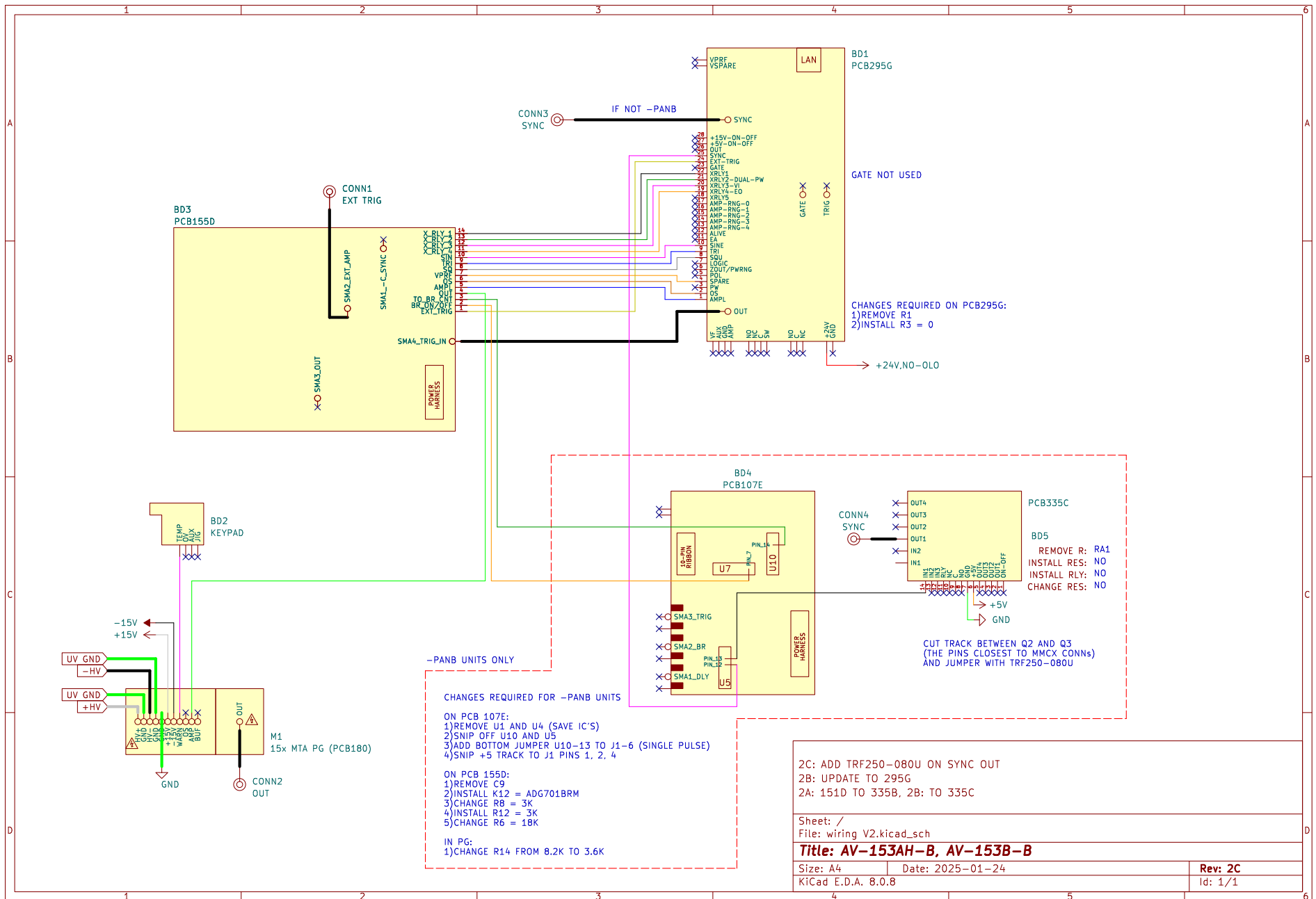

2C: ADD TRF250-080U ON SYNC OUT  
 2B: UPDATE TO 295G  
 2A: 151D TO 335B, 2B: TO 335C

Sheet: /  
 File: wiring V2.kicad\_sch  
**Title: AV-153AH-B, AV-153B-B**

PERFORMANCE CHECK SHEET