



AVTECH ELECTROSYSTEMS LTD.

NANOSECOND WAVEFORM ELECTRONICS  
SINCE 1975

P.O. BOX 265  
OGDENSBURG, NY  
U.S.A. 13669-0265  
TEL: (315) 472-5270  
FAX: (613) 226-2802

TEL: 1-800-265-6681  
FAX: 1-800-561-1970

e-mail: [info@avtechpulse.com](mailto:info@avtechpulse.com)  
<http://www.avtechpulse.com/>

BOX 5120, LCD MERIVALE  
OTTAWA, ONTARIO  
CANADA K2C 3H4  
TEL: (613) 226-5772  
FAX: (613) 226-2802

## INSTRUCTIONS

MODEL AV-153B-B

0 to  $\pm 135$ V AMPLITUDE  
HIGH-VOLTAGE FUNCTION GENERATOR  
AND VARIABLE-GAIN LINEAR AMPLIFIER  
WITH IEEE 488.2 AND RS-232 CONTROL

SERIAL NUMBER: \_\_\_\_\_

### WARRANTY

Avtech Electrosystems Ltd. warrants products of its manufacture to be free from defects in material and workmanship under conditions of normal use. If, within one year after delivery to the original owner, and after prepaid return by the original owner, this Avtech product is found to be defective, Avtech shall at its option repair or replace said defective item. This warranty does not apply to units which have been disassembled, modified or subjected to conditions exceeding the applicable specifications or ratings. This warranty is the extent of the obligation assumed by Avtech with respect to this product and no other warranty or guarantee is either expressed or implied.

### TECHNICAL SUPPORT

Phone: 613-226-5772 or 1-800-265-6681

Fax: 613-226-2802 or 1-800-561-1970

E-mail: [info@avtechpulse.com](mailto:info@avtechpulse.com)

World Wide Web: <http://www.avtechpulse.com>

## TABLE OF CONTENTS

<b>WARRANTY</b> .....	<b>2</b>
<b>TECHNICAL SUPPORT</b> .....	<b>2</b>
<b>TABLE OF CONTENTS</b> .....	<b>3</b>
<b>INTRODUCTION</b> .....	<b>5</b>
<b>HIGH-VOLTAGE PRECAUTIONS</b> .....	<b>6</b>
<b>SPECIFICATIONS</b> .....	<b>7</b>
<b>EUROPEAN REGULATORY NOTES</b> .....	<b>8</b>
<b>EC DECLARATION OF CONFORMITY</b> .....	<b>8</b>
<b>DIRECTIVE 2002/95/EC (RoHS)</b> .....	<b>8</b>
<b>INSTALLATION</b> .....	<b>9</b>
<b>VISUAL CHECK</b> .....	<b>9</b>
<b>POWER RATINGS</b> .....	<b>9</b>
<b>CONNECTION TO THE POWER SUPPLY</b> .....	<b>9</b>
<b>ENVIRONMENTAL CONDITIONS</b> .....	<b>10</b>
<b>FUSES</b> .....	<b>11</b>
<b>AC FUSE REPLACEMENT</b> .....	<b>11</b>
<b>DC FUSE REPLACEMENT</b> .....	<b>12</b>
<b>FUSE RATINGS</b> .....	<b>12</b>
<b>FRONT PANEL CONTROLS</b> .....	<b>13</b>
<b>REAR PANEL CONTROLS</b> .....	<b>15</b>
<b>GENERAL INFORMATION</b> .....	<b>17</b>
<b>WAVESHAPe SELECTION</b> .....	<b>17</b>
<b>SINE, TRIANGLE, AND SQUARE WAVE GENERATION</b> .....	<b>17</b>
<b>PULSE GENERATION</b> .....	<b>18</b>
<b>AMPLIFY MODE</b> .....	<b>18</b>
<b>DC OFFSET</b> .....	<b>19</b>
<b>CABLE LENGTHS</b> .....	<b>19</b>
<b>-PANB BURST MODE OPTION</b> .....	<b>20</b>
<b>LOCAL MODE</b> .....	<b>20</b>
<b>REMOTE MODE</b> .....	<b>20</b>
<b>OPERATIONAL CHECK</b> .....	<b>21</b>
<b>PROGRAMMING YOUR PULSE GENERATOR</b> .....	<b>24</b>

KEY PROGRAMMING COMMANDS.....	24
ALL PROGRAMMING COMMANDS.....	25
<b>OTHER INFORMATION.....</b>	<b>27</b>
APPLICATION NOTES.....	27
MANUAL FEEDBACK.....	27
<b>MECHANICAL INFORMATION.....</b>	<b>28</b>
TOP COVER REMOVAL.....	28
RACK MOUNTING.....	28
ELECTROMAGNETIC INTERFERENCE.....	28
<b>MAINTENANCE.....</b>	<b>29</b>
REGULAR MAINTENANCE.....	29
CLEANING.....	29
<b>WIRING DIAGRAMS.....</b>	<b>30</b>
WIRING OF AC POWER.....	30
PCB 158G - LOW VOLTAGE POWER SUPPLY, 1/3.....	31
PCB 158G - LOW VOLTAGE POWER SUPPLY, 2/3.....	32
PCB 158G - LOW VOLTAGE POWER SUPPLY, 3/3.....	33
HIGH-VOLTAGE DC POWER SUPPLIES.....	34
PCB 170 - HIGH-VOLTAGE POWER SUPPLY.....	35
PCB 104D - KEYPAD / DISPLAY BOARD, 1/3.....	36
PCB 104D - KEYPAD / DISPLAY BOARD, 2/3.....	37
PCB 104D - KEYPAD / DISPLAY BOARD, 3/3.....	38
WIRING OF TIMING BOARDS.....	39
<b>PERFORMANCE CHECK SHEET.....</b>	<b>40</b>

## INTRODUCTION

The AV-153B-B is a high-performance GPIB and RS232-equipped function generator that can produce square, sine, triangle, and pulse outputs at frequencies up to 50 kHz, with peak amplitudes of 0 to 135V. For the sine, triangle, and square wave modes, this produces peak-to-peak amplitudes of up to 270V.

The AV-153B-B will drive load impedances of 500Ω or higher.

When supplied with an external voltage input, the AV-153B-B may be used as a DC to 50 kHz variable-gain linear amplifier. The maximum input voltage in this mode is ±2V. The gain is variable from 0 up to  $135V \div 2V = 67.5$ .

The AV-153B-B features front panel keyboard and adjust knob control of the output pulse parameters along with a four line by 40 character back-lit LCD display of the output amplitude, waveshape, and frequency. The instrument includes memory to store up to four complete instrument setups. The operator may use the front panel or the computer interface to store a complete “snapshot” of all key instrument settings, and recall this setup at a later time.

This instrument is intended for use in research and development laboratories.

## HIGH-VOLTAGE PRECAUTIONS

 **CAUTION:** This instrument provides output voltages as high as  $\pm 135$  Volts, so extreme caution must be employed when using this instrument. The instrument should only be used by individuals who are thoroughly skilled in high voltage laboratory techniques. The following precaution should always be observed:

1. Keep exposed high-voltage wiring to an absolute minimum.
2. Wherever possible, use shielded connectors and cabling.
3. Connect and disconnect loads and cables only when the amplifier is turned off.
4. Keep in mind that all cables, connectors, oscilloscope probes, and loads must have an appropriate voltage rating.
5. Do not attempt any repairs on the instrument, beyond the fuse replacement procedures described in this manual. Contact Avtech technical support (see page 2 for contact information) if the instrument requires servicing.

## SPECIFICATIONS

Model:	AV-153B-B <sup>2</sup>
Maximum amplitude & maximum peak output <sup>3</sup> :	0 to $\pm$ 135 Volts
DC offset <sup>3</sup> :	0 to $\pm$ 115 Volts
Load resistance:	$\geq$ 500 Ohms
Average output power:	40 Watts maximum
Minimum frequency:	1 Hz
Maximum frequency:	50 kHz
Square wave rise time <sup>4</sup> :	1 $\mu$ s
Waveforms:	Sine, square, triangle, and amplifier mode. Models with the -B suffix also have a pulse mode of operation.
Amplifier mode:	Input amplitude for maximum output: $\pm$ 2 Volts (1 k $\Omega$ input impedance)
Pulse width (FWHM):	5 $\mu$ s to 500 ms. 80% max. duty cycle.
Burst mode:	Optional <sup>5</sup> . This allows the generation of a burst of 1-500 cycles of sine, square, triangle, or pulse waveforms. This burst may be triggered by pressing a front-panel pushbutton, or by computer command.
GPIB / RS-232 control <sup>2</sup> :	Standard on -B units.
Telnet / Ethernet control <sup>6</sup> :	Optional. See <a href="http://www.avtechpulse.com/options/tnt">http://www.avtechpulse.com/options/tnt</a> for details.
Connectors:	BNC
Power requirement:	100 - 240 Volts, 50 - 60 Hz
Dimensions:	100 mm x 430 mm x 375 mm 3.9" x 17" x 14.8" (H x W x D)

- 1) -C suffix indicates stand-alone lab instrument with internal clock and line powering. (See <http://www.avtechpulse.com/formats/> for details of the instrument formats).
- 2) -B suffix indicates IEEE-488.2 GPIB and RS-232 control of amplitude and frequency. See <http://www.avtechpulse.com/gpib/> for details.
- 3) Peak output = amplitude + offset. The amplitude and offset can not be set to maximum at the same time, or the peak output rating will be exceeded.
- 4) The non-zero rise time will also distort the sine and triangle waveforms when operating near the maximum rated frequency. All rise times are measured on a 20%-80% basis.
- 5) Add the suffix -PANB to the model number to specify the burst mode option.
- 6) Add the suffix -TNT to the model number to specify the Telnet / Ethernet control option.

## EUROPEAN REGULATORY NOTES

### EC DECLARATION OF CONFORMITY

We

Avtech Electrosystems Ltd.  
P.O. Box 5120, LCD Merivale  
Ottawa, Ontario  
Canada K2C 3H4

declare that this pulse generator meets the intent of Directive 89/336/EEC for Electromagnetic Compatibility. Compliance pertains to the following specifications as listed in the official Journal of the European Communities:

EN 50081-1 Emission

EN 50082-1 Immunity

and that this pulse generator meets the intent of the Low Voltage Directive 72/23/EEC as amended by 93/68/EEC. Compliance pertains to the following specifications as listed in the official Journal of the European Communities:

EN 61010-1:2001 Safety requirements for electrical equipment for measurement, control, and laboratory use



### DIRECTIVE 2002/95/EC (RoHS)

This instrument is exempt from Directive 2002/95/EC of the European Parliament and of the Council of 27 January 2003 on the Restriction of the use of certain Hazardous Substances (RoHS) in electrical and electronic equipment. Specifically, Avtech instruments are considered "Monitoring and control instruments" (Category 9) as defined in Annex 1A of Directive 2002/96/EC. The Directive 2002/95/EC only applies to Directive 2002/96/EC categories 1-7 and 10, as stated in the "Article 2 - Scope" section of Directive 2002/95/EC.



## INSTALLATION

### VISUAL CHECK

After unpacking the instrument, examine to ensure that it has not been damaged in shipment. Visually inspect all connectors, knobs, liquid crystal displays (LCDs), and the handles. Confirm that a power cord, a GPIB cable, and two instrumentation manuals (this manual and the “Programming Manual for -B Instruments”) are with the instrument. If the instrument has been damaged, file a claim immediately with the company that transported the instrument.

### POWER RATINGS

This instrument is intended to operate from 100 - 240 V, 50 - 60 Hz.

The maximum power consumption is 150 Watts. Please see the “FUSES” section for information about the appropriate AC and DC fuses.

This instrument is an “Installation Category II” instrument, intended for operation from a normal single-phase supply.

### CONNECTION TO THE POWER SUPPLY

An IEC-320 three-pronged recessed male socket is provided on the back panel for AC power connection to the instrument. One end of the detachable power cord that is supplied with the instrument plugs into this socket. The other end of the detachable power cord plugs into the local mains supply. Use only the cable supplied with the instrument. The mains supply must be earthed, and the cord used to connect the instrument to the mains supply must provide an earth connection. (The supplied cord does this.) The table below describes the power cord that is supplied with this instrument, depending on the destination region:

Destination Region	Description	Volex ( <a href="http://www.volex.com">http://www.volex.com</a> ) Part Number	Newark ( <a href="http://www.newark.com">http://www.newark.com</a> ) Stock Number
Continental Europe	European CEE 7/7 “Schuko” 230V, 50Hz	17850-C3-326	44F1841
United Kingdom	BS 1363, 230V, 50Hz	17962-C3-10	84F1025
Switzerland	SEV 1011, 230V, 50Hz	2102H-C3-10	93F2452
Israel	SI 32, 220V, 50Hz	2115H-C3-10	04F1115
North America, and all other areas	NEMA 5-15, 120V, 60 Hz	17250-B1-10	36F1255

## ENVIRONMENTAL CONDITIONS

This instrument is intended for use under the following conditions:

1. indoor use;
2. altitude up to 2 000 m;
3. temperature 5 °C to 40 °C;
4. maximum relative humidity 80 % for temperatures up to 31 °C decreasing linearly to 50 % relative humidity at 40 °C;
5. Mains supply voltage fluctuations up to  $\pm 10$  % of the nominal voltage;
6. no pollution or only dry, non-conductive pollution.

## FUSES

This instrument contains four fuses. All are accessible from the rear-panel. Two protect the AC prime power input, and two protect the internal DC power supplies. The locations of the fuses on the rear panel are shown in the figure below:

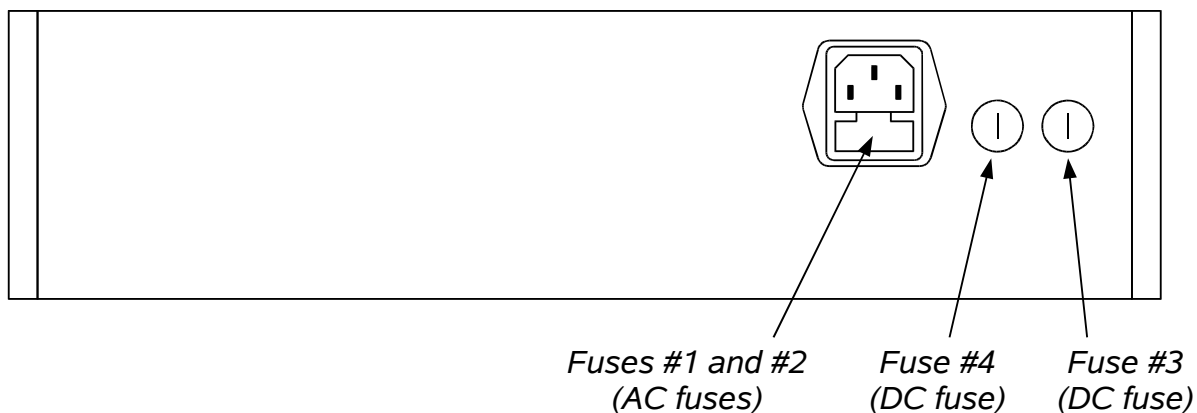

### AC FUSE REPLACEMENT

To physically access the AC fuses, the power cord must be detached from the rear panel of the instrument. The fuse drawer may then be extracted using a small flat-head screwdriver, as shown below:

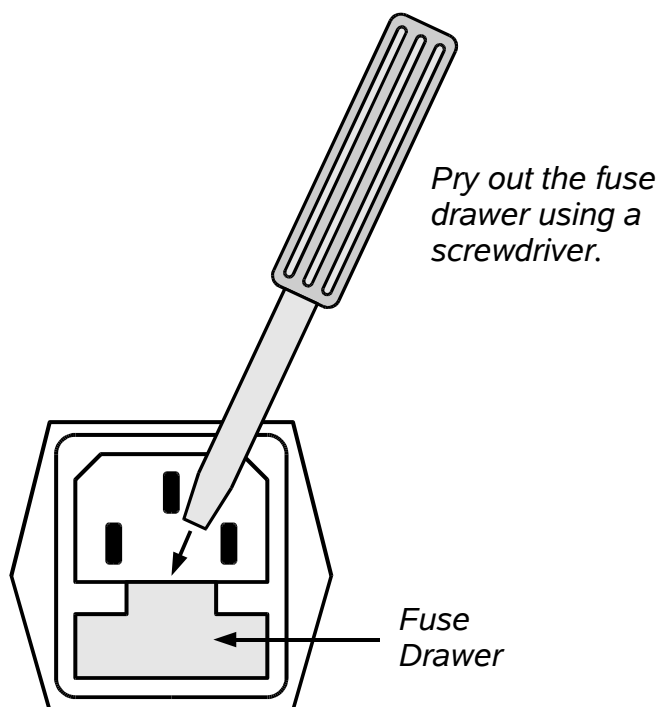

## DC FUSE REPLACEMENT

The DC fuses may be replaced by inserting the tip of a flat-head screwdriver into the fuse holder slot, and rotating the slot counter-clockwise. The fuse and its carrier will then pop out.

## FUSE RATINGS

The following table lists the required fuses:

Fuses	Nominal Mains Voltage	Rating	Case Size	Manufacturer's Part Number (Wickmann)	Distributor's Part Number (Digi-Key)
#1, #2 (AC)	115 V	1.6A, 250V, Time-Delay	5×20 mm	1951160000	WK5053-ND
	230 V	0.8A, 250V, Time-Delay	5×20 mm	1950800000	WK5046-ND
#3 (DC)	N/A	1.0A, 250V, Time-Delay	5×20 mm	1951100000	WK5048-ND
#4 (DC)	N/A	3.15A, 250V, Time-Delay	5×20 mm	1951315000	WK5124-ND

The fuse manufacturer is Wickmann (<http://www.wickmann.com/>).

Replacement fuses may be easily obtained from Digi-Key (<http://www.digikey.com/>) and other distributors.

## FRONT PANEL CONTROLS

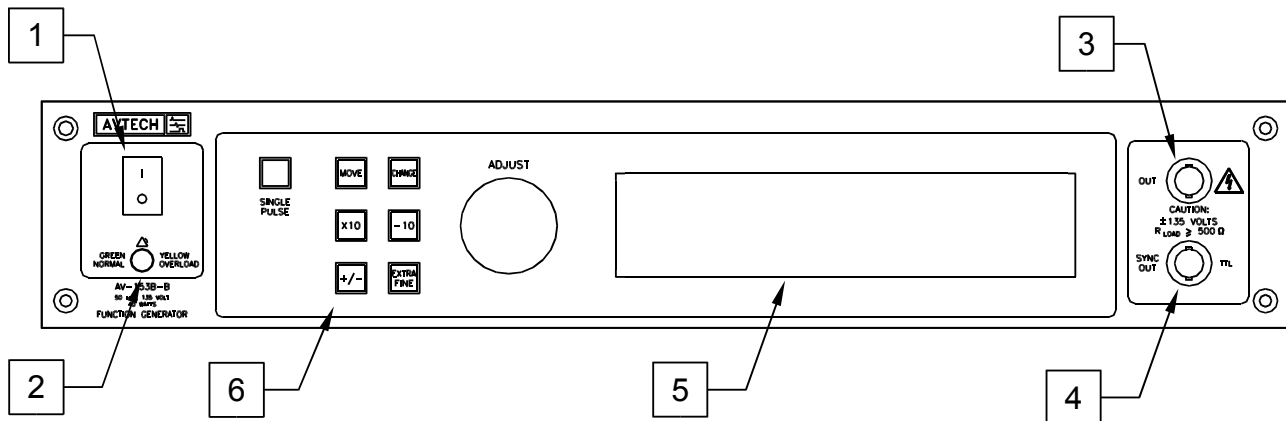

1. POWER Switch. This is the main power switch. When turning the instrument on, there may be a delay of several seconds before the instrument appears to respond.
2. OVERLOAD Indicator. When the instrument is powered, this indicator is normally green, indicating normal operation. If this indicator is yellow, an internal automatic overload protection circuit has been tripped. If the unit is overloaded (by operating at an exceedingly high duty cycle or by operating into a very low impedance), the protective circuit will disable the output of the instrument and turn the indicator light yellow. The light will stay yellow (i.e. output disabled) for about 5 seconds after which the instrument will attempt to re-enable the output (i.e. light green) for about 1 second. If the overload condition persists, the output will be disabled again (i.e. light yellow) for another 5 seconds. If the overload condition has been removed, the instrument will resume normal operation.

This overload indicator may flash yellow briefly at start-up. This is not a cause for concern.

Note that the output stage will safely withstand a short-circuited load condition.

3. OUT Connector. This BNC connector provides the main output signal, into load impedances of  $> 500\Omega$ .

 **Caution:** Voltages as high as  $\pm 135\text{V}$  may be present on the center conductor of this output connector. Avoid touching this conductor. Connect to this connector using standard coaxial cable, to ensure that the center conductor is not exposed.

4. SYNC OUT. This connector supplies a SYNC output that can be used to trigger other equipment, particularly oscilloscopes. This signal has an approximate amplitude of  $+3\text{ Volts}$  to  $R_L > 1\text{ k}\Omega$  with a pulse width of approximately  $100\text{ ns}$ .
5. LIQUID CRYSTAL DISPLAY (LCD). This LCD is used in conjunction with the keypad to change the instrument settings. Normally, the main menu is displayed, which lists the key adjustable parameters and their current values. The

“Programming Manual for -B Instruments” describes the menus and submenus in detail.

## 6. KEYPAD.

Control Name	Function
MOVE	This moves the arrow pointer on the display.
CHANGE	This is used to enter the submenu, or to select the operating mode, pointed to by the arrow pointer.
× 10	If one of the adjustable numeric parameters is displayed, this increases the setting by a factor of ten.
÷ 10	If one of the adjustable numeric parameters is displayed, this decreases the setting by a factor of ten.
+/-	If one of the adjustable numeric parameters is displayed, and this parameter can be both positive or negative, this changes the sign of the parameter.
EXTRA FINE	This changes the step size of the ADJUST knob. In the extra-fine mode, the step size is twenty times finer than in the normal mode. This button switches between the two step sizes.
ADJUST	This large knob adjusts the value of any displayed numeric adjustable values, such as frequency, pulse width, etc. The adjust step size is set by the "EXTRA FINE" button.  When the main menu is displayed, this knob can be used to move the arrow pointer.

## REAR PANEL CONTROLS

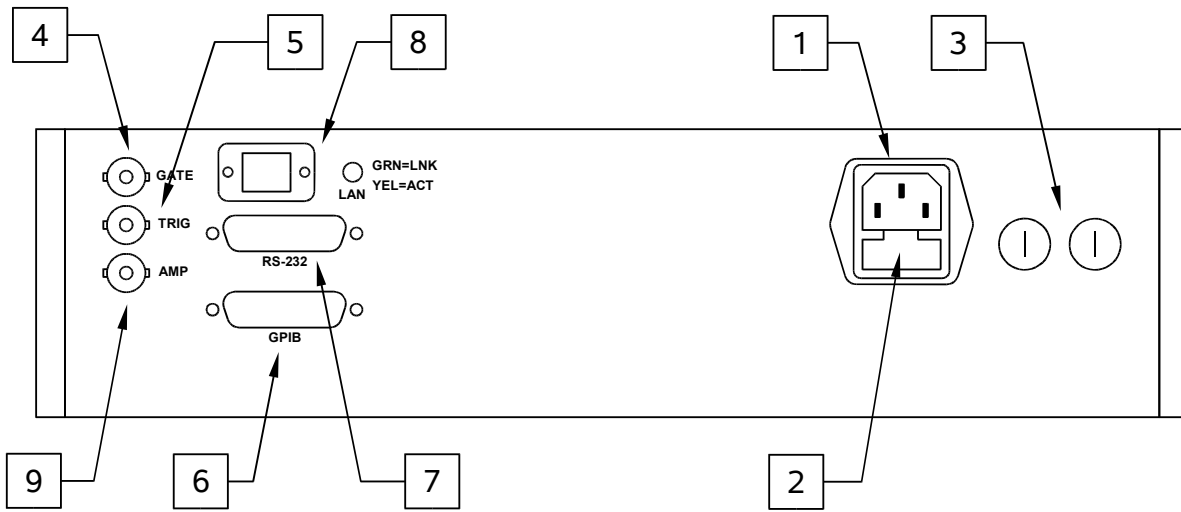

1. AC POWER INPUT. An IEC-320 C14 three-pronged recessed male socket is provided on the back panel for AC power connection to the instrument. One end of the detachable power cord that is supplied with the instrument plugs into this socket.
2. AC FUSE DRAWER. The two fuses that protect the AC input are located in this drawer. Please see the “FUSES” section of this manual for more information.
3. DC FUSES. These two fuses protect the internal DC power supplies. Please see the “FUSES” sections of this manual for more information.
4. GATE. This feature is not present on the AV-153B-B.
5. TRIG. When the AV-153B-B is set to operate in the amplifier mode, the externally-generated input signal is applied to this connector. The maximum input voltage is  $\pm 2V$ . The input impedance of this input is 1 k $\Omega$ . (Depending on the length of cable attached to this input, and the source driving it, it may be desirable to add a coaxial 50 Ohm terminator to this input to provide a proper transmission line termination. The Pasternack ([www.pasternack.com](http://www.pasternack.com)) PE6008-50 BNC feed-thru 50 Ohm terminator is suggested for this purpose.)
6. GPIB Connector. A standard GPIB cable can be attached to this connector to allow the instrument to be computer-controlled. See the “Programming Manual for -B Instruments” for more details on GPIB control.
7. RS-232 Connector. A standard serial cable with a 25-pin male connector can be attached to this connector to allow the instrument to be computer-controlled. See the “Programming Manual for -B Instruments” for more details on RS-232 control.
8. LAN Connector and Indicator. (Optional feature. Present on -TNT units only.) The -TNT option "Internet-enables" Avtech pulse generators by adding this standard

Ethernet port to the rear panel, in addition to the IEEE-488.2 GPIB and RS-232 ports normally found on "-B" units. Commands are sent using the standard Telnet protocol. The SCPI-compliant command set is the same as that used for GPIB and RS-232 control. The -TNT option uses the Dynamic Host Configuration Protocol (DHCP) to obtain its network address. A DHCP server must be present on the local network for the -TNT option to operate properly.

9. AMP Connector. This feature is not present on the AV-153B-B.



## GENERAL INFORMATION

### WAVESHAPE SELECTION

The front-panel “SHAPE” menu or the “sour:func” computer command can be used to set the output waveform to one of five possible modes:

- SINE – This mode generates a bipolar sinusoidal signal with 50% duty cycle.
- TRIANGLE – This mode generates a bipolar triangle-wave signal with 50% duty cycle.
- SQUARE – This mode generates a bipolar square-wave signal with 50% duty cycle.
- PULSE – This mode generates a unipolar pulse signal, with adjustable pulse width.
- AMPLIFY – This mode causes the instrument to amplify an externally-generated signal.

### SINE, TRIANGLE, AND SQUARE WAVE GENERATION

When set to the SINE, TRIANGLE, or SQUARE modes, the output frequency and peak amplitude are controlled from the front panel (or by computer command). The output signal in these modes is bipolar (i.e., the signal swings from a positive value to an approximately equal negative amplitude), and the duty cycle is nominally 50% (i.e., time that the signal is positive is equal in length to the time that the signal is negative.)

These waveforms are illustrated below:

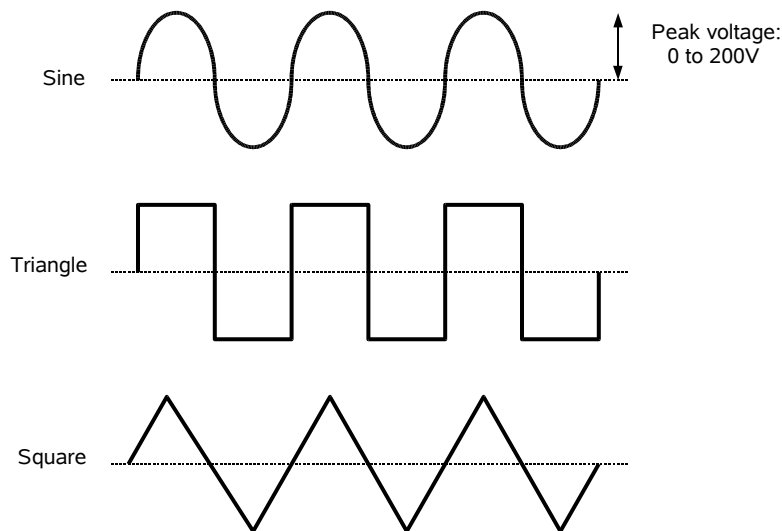

A SYNC output is provided on the front-panel. This provides a 100 ns, 3V signal for triggering oscilloscopes or other equipment. In these modes, the delay (or relative phase) between the main output and the SYNC output is not adjustable.

## PULSE GENERATION

The AV-153B-B can also act as a pulse generator, with variable delay between the SYNC output and the main output. In this mode, the pulse width may be varied over a wide range (5  $\mu$ s to 500 ms), and the amplitude may be varied from 0 to +135V. (Negative pulses can not be generated directly. However, they can be generated indirectly by adding a negative DC offset. See the offset discussion below.) The maximum duty cycle ( $100\% \times \text{Pulse Width} / \text{Period}$ ) is 80%.

The outputs in this mode are shown below, assuming that the delay is set to a positive value:

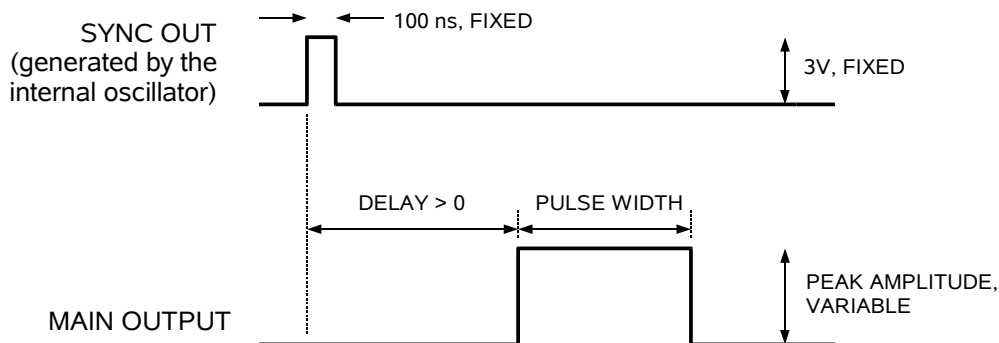

If the delay is negative, the order of the SYNC and OUT pulses is reversed:

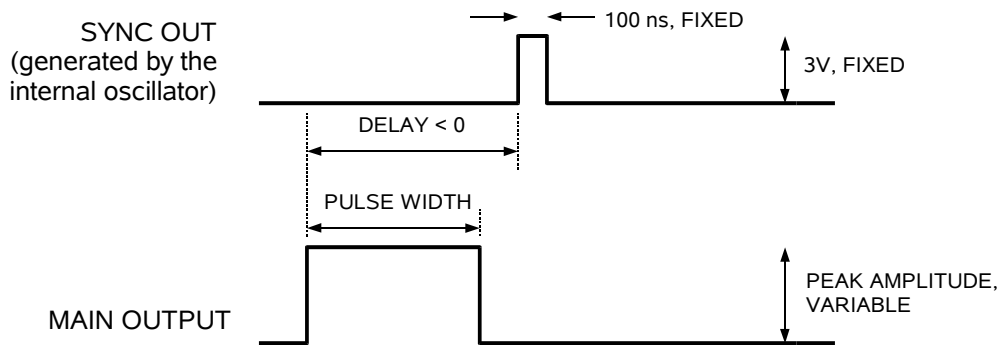

## AMPLIFY MODE

When the AMPLIFY mode is enabled, AV-153B-B may be used as a DC-50 kHz variable-gain linear amplifier. The maximum gain is  $135\text{V} \div 2\text{V} = 67.5$ . The maximum input signal is  $\pm 2\text{V}$ . The gain is adjusted by varying the amplitude setting, which corresponds to the output that would be obtained for a +2V input. (For instance, to obtain a gain of +50, set the amplitude to +100V. If a -0.8V signal is applied, for instance, the actual output would be -40V, not +100V.)

The required voltage input signal is applied at TRIG for this mode of operation.

This mode is illustrated below:

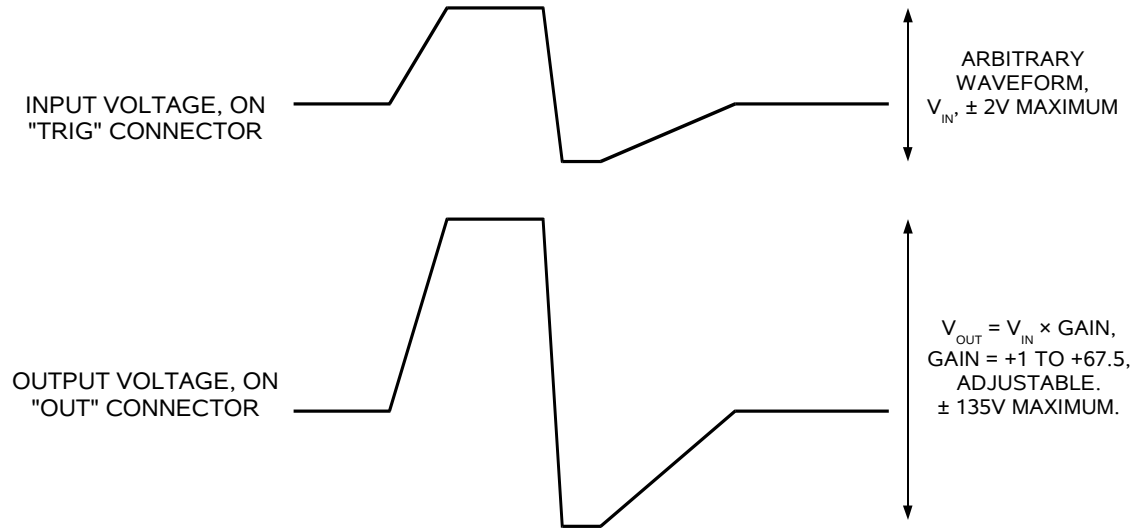

### DC OFFSET

In all modes, a DC offset may be added to the output signal. The DC offset can be set between -115V and +115V. The total output (amplitude + offset) can not exceed  $\pm 135V$ .

### CABLE LENGTHS

The length of cable used to connect the load to the output of the function generator should be less than 3 feet (1 meter), and ideally less than 18 inches (0.5 meters). At longer lengths, the transmission line reflections caused by the cabling will distort the output signal, particularly if the "square" waveform mode is used.

### -PANB BURST MODE OPTION

The -PANB option allows the generation of a burst of 1-500 cycles of sine, square, triangle, or pulse waveforms. This burst may be triggered by pressing a front-panel pushbutton, or by computer command.

 Beware that the instrument generates a burst output every time the pulse count (N) is changed (e.g., when the pulse:count command is sent, or when the pulse count is adjusted from the front panel).

### LOCAL MODE

The number of waveform cycle in each burst can be controlled from the front panel. The display normally shows “N=xxx” (xxx may range from 0 to 500), where N is the number of cycles in each burst.

When N=0, the instrument generates the output signal continuously – that is, the burst mode is disabled.

When N>0, the instrument is in burst mode. A burst may be triggered by pressing the “SINGLE PULSE” pushbutton.

A burst is also triggered any time that the value of the pulse count (N) is changed. For instance, when the ADJUST knob is rotated when the pulse count menu is displayed, a burst will be generated each time N increments or decrements. If this triggering is undesirable, set the amplitude to zero before adjusting the pulse count, and return the amplitude to the desired value after the pulse count is set properly.

### REMOTE MODE

When controlling the instrument from the GPIB or RS-232 ports, the burst mode is controlled using the “pulse:count” command.

Sending “pulse:count 0” disables the burst mode. That is, the instrument generates the output signal continuously.

Sending “pulse:count xxx”, where xxx is a number between 1 and 500, triggers a burst with xxx cycles of the output waveform.

The front-panel “SINGLE PULSE” pushbutton remains active in the remote mode. Pressing the “SINGLE PULSE” pushbutton after a “pulse:count” command will generate a burst, using the most recent pulse count setting.

## OPERATIONAL CHECK

This section describes a sequence to confirm the basic operation of the instrument. It should be performed after receiving the instrument. It is a useful learning exercise as well.

Before proceeding with this procedure, finish reading this instruction manual thoroughly. Then read the “Local Control” section of the “Programming Manual for -B Instruments” thoroughly. The “Local Control” section describes the front panel controls used in this operational check - in particular, the MOVE, CHANGE, and ADJUST controls.

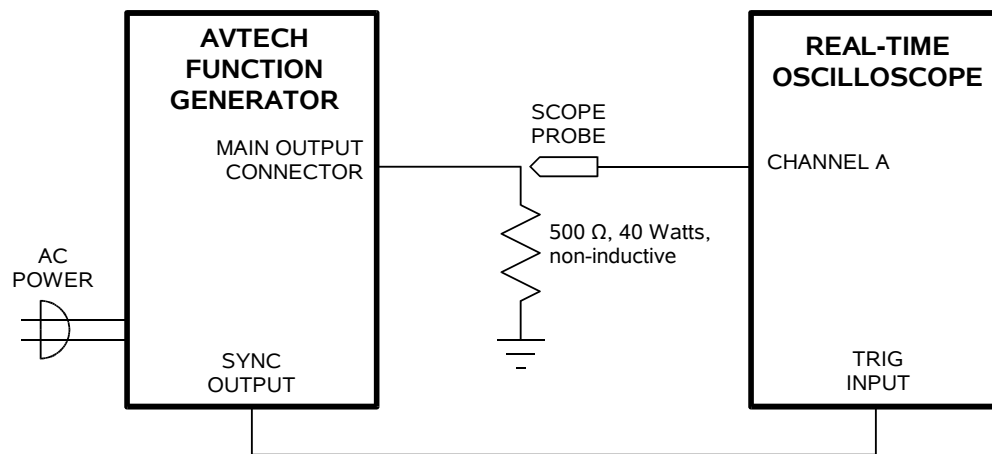

*Basic Test Arrangement*

1. Connect a non-inductive 500Ω, 40W test load between the OUT connector and ground. Note: wirewound resistors are very inductive. Avoid them. Factory tests are conducted using twenty fan-cooled 10 kΩ Ohm, 2W Ohmite OY-series resistors (model OY103K) connected in parallel. See [www.ohmite.com](http://www.ohmite.com) for information on OY resistors. These resistors may be purchased readily at [www.digikey.com](http://www.digikey.com). If desired, a higher-resistance, lower-power load may be used to simplify the test. The required load power rating for a given resistance is  $(135V)^2 / R_{LOAD}$ , where  $R_{LOAD}$  is in Ohms.

Confirm that the oscilloscope and the test load are rated for ±135 Volt operation.

2. Connect a cable from the SYNC connector to the TRIG input of an oscilloscope. Set the oscilloscope to trigger externally.
3. Connect an oscilloscope probe to the load. On the oscilloscope, set the vertical scale to 50 V/div, and the horizontal scale to 50 us/div.

4. Turn on the AV-153B-B. The main menu will appear on the LCD.
5. To set the AV-153B-B to trigger from the internal clock at a PRF of 10 kHz:
  - a) The arrow pointer should be pointing at the frequency menu item. If it is not, press the MOVE button until it is.
  - b) Press the CHANGE button. The frequency submenu will appear. Rotate the ADJUST knob until the frequency is set at 10 kHz.
  - c) Press CHANGE to return to the main menu.
6. To set the waveshape to a sinusoid:
  - a) Press the MOVE button until the arrow pointer is pointing at the shape menu item.
  - b) Press the CHANGE button. The delay submenu will appear.
  - c) Press MOVE until the arrow pointer is pointing at the "SINE" choice.
  - d) Press CHANGE to return to the main menu.
7. At this point, nothing should appear on the oscilloscope.
8. To enable the output:
  - a) Press the MOVE button until the arrow pointer is pointing at the output menu item.
  - b) Press the CHANGE button. The output submenu will appear.
  - c) Press MOVE until the arrow pointer is pointing at the "ON" choice.
  - d) Press CHANGE to return to the main menu.
9. To change the output amplitude:
  - a) Press the MOVE button until the arrow pointer is pointing at the amplitude menu item.
  - b) Press the CHANGE button. The amplitude submenu will appear. Rotate the ADJUST knob until the amplitude is set at +135V.
  - c) Observe the oscilloscope. You should see a 10 kHz, 135V peak (270V peak-to-peak) sine wave.

d) Press CHANGE to return to the main menu.

This completes the operational check.

If additional assistance is required:

Tel: (613) 226-5772

Fax: (613) 226-2802

Email: [info@avtechpulse.com](mailto:info@avtechpulse.com)

## PROGRAMMING YOUR PULSE GENERATOR

### KEY PROGRAMMING COMMANDS

The “Programming Manual for -B Instruments” describes in detail how to connect the pulse generator to your computer, and the programming commands themselves. A large number of commands are available; however, normally you will only need a few of these. Here is a basic sample sequence of commands that might be sent to the instrument after power-up, using the internal trigger source:

*rst	(resets the instrument)
sour:func sin	(selects a sine wave output)
frequency 1000 Hz	(sets the frequency to 1000 Hz)
output on	(turns on the output)
volt 50	(sets the amplitude to 50 V)
volt:low -100	(sets the offset to +10 V)

To generate a pulse output, use:

*rst	(resets the instrument)
sour:func pulse	(selects a unipolar pulse output)
frequency 1000 Hz	(sets the frequency to 1000 Hz)
pulse:width 10 us	(sets the pulse width to 10 us)
pulse:delay 1 us	(sets the delay to 1 us)
output on	(turns on the output)
volt 50	(sets the amplitude to 50 V)
volt:low -100	(sets the offset to -100 V)

To amplify an external signal, use:

*rst	(resets the instrument)
sour:func amp	(enables the amplifier mode)
output on	(turns on the output)
volt 135	(sets the gain to $135 / 2 = 67.5$ )
volt:low -100	(sets the offset to -100 V)

To generate a burst of sine wave cycles (for units with the -PANB option only), use:

*rst	(resets the instrument)
sour:func sin	(selects a sine wave output)
frequency 1000 Hz	(sets the frequency to 1000 Hz)
pulse:count 7	(disables continuous output mode – no burst though, because the amplitude is zero)



output on	(turns on the output)
volt 150	(sets the amplitude to 150 V)
pulse:count 7	(generates a burst of 7 sine wave cycles)

These commands will satisfy 90% of your programming needs.

## ALL PROGRAMMING COMMANDS

For more advanced programmers, a complete list of the available commands is given below. These commands are described in detail in the “Programming Manual for -B Instruments”. (Note: this manual also includes some commands that are not implemented in this instrument. They can be ignored.)

<u>Keyword</u>	<u>Parameter</u>	<u>Notes</u>
LOCAL		
OUTPut:		
:[STATe]	<boolean value>	
:PROTection		
:TRIPped?		[query only]
REMOTE		
[SOURce]:		
:FREQuency		
[:CW   FIXed]	<numeric value>	
:FUNcTion		
:[SHAPE]	AMPlify   PULSe   SINusoid   SQUare   TRIangle	
:PULSe		
:PERiod	<numeric value>	
:WIDTh	<numeric value>   IN	
:DELay	<numeric value>	
:VOLTage		
[:LEVe]		
[:IMMediate]		
[:AMPLitude]	<numeric value>	
:LOW	<numeric value>	
:PROTection		
:TRIPped?		[query only]
STATUS:		
:OPERation		
:[EVENT]?		[query only, always returns "0"]
:CONDition?		[query only, always returns "0"]
:ENABle	<numeric value>	[implemented but not useful]
:QUEStionable		
:[EVENT]?		[query only, always returns "0"]
:CONDition?		[query only, always returns "0"]
:ENABle	<numeric value>	[implemented but not useful]
SYSTEM:		
:COMMunicate		
:GPIB		
:ADDReSS	<numeric value>	
:SERial		
:CONTRol		
:RTS	ON   IBFull   RFR	

:[RECeive]		
:BAUD	1200   2400   4800   9600	
:BITS	7   8	
:ECHO	<boolean value>	
:PARity		
:[TYPE]	EVEN   ODD   NONE	
:SBITS	1   2	
:ERRor		
:[NEXT]?		[query only]
:COUNT?		[query only]
:VERSion?		[query only]
TRIGger:		
:SOURce	INTernal   EXTernal   MANual   HOLD   IMMEDIATE	
*CLS		[no query form]
*ESE	<numeric value>	
*ESR?		[query only]
*IDN?		[query only]
*OPC		
*SAV	0   1   2   3	[no query form]
*RCL	0   1   2   3	[no query form]
*RST		[no query form]
*SRE	<numeric value>	
*STB?		[query only]
*TST?		[query only]
*WAI		[no query form]

## OTHER INFORMATION

### APPLICATION NOTES

Application notes are available on the Avtech web site, at <http://www.avtechpulse.com/appnote>.

### MANUAL FEEDBACK

Please report any errors or omissions in this manual, or suggestions for improvement, to [info@avtechpulse.com](mailto:info@avtechpulse.com). Thanks!

## MECHANICAL INFORMATION

### TOP COVER REMOVAL

If necessary, the interior of the instrument may be accessed by removing the four Phillips screws on the top panel. With the four screws removed, the top cover may be slid back (and off).

Always disconnect the power cord before opening the instrument.

There are no user-adjustable internal circuits. For repairs other than fuse replacement, please contact Avtech (info@avtechpulse.com) to arrange for the instrument to be returned to the factory for repair.



Caution: High voltages are present inside the instrument during normal operation. Do not operate the instrument with the cover removed.

### RACK MOUNTING

A rack mounting kit is available. The -R5 rack mount kit may be installed after first removing the one Phillips screw on the side panel adjacent to the front handle.

### ELECTROMAGNETIC INTERFERENCE

To prevent electromagnetic interference with other equipment, all used outputs should be connected to shielded loads using shielded coaxial cables. Unused outputs should be terminated with shielded terminators or with shielded dust caps, to prevent unintentional electromagnetic radiation. All cords and cables should be less than 3m in length.

## MAINTENANCE

### REGULAR MAINTENANCE

This instrument does not require any regular maintenance.

On occasion, one or more of the four rear-panel fuses may require replacement. All fuses can be accessed from the rear panel. See the “FUSES” section for details.

### CLEANING

If desired, the interior of the instrument may be cleaned using compressed air to dislodge any accumulated dust. (See the “TOP COVER REMOVAL” section for instructions on accessing the interior.) No other cleaning is recommended.

# WIRING DIAGRAMS

## WIRING OF AC POWER

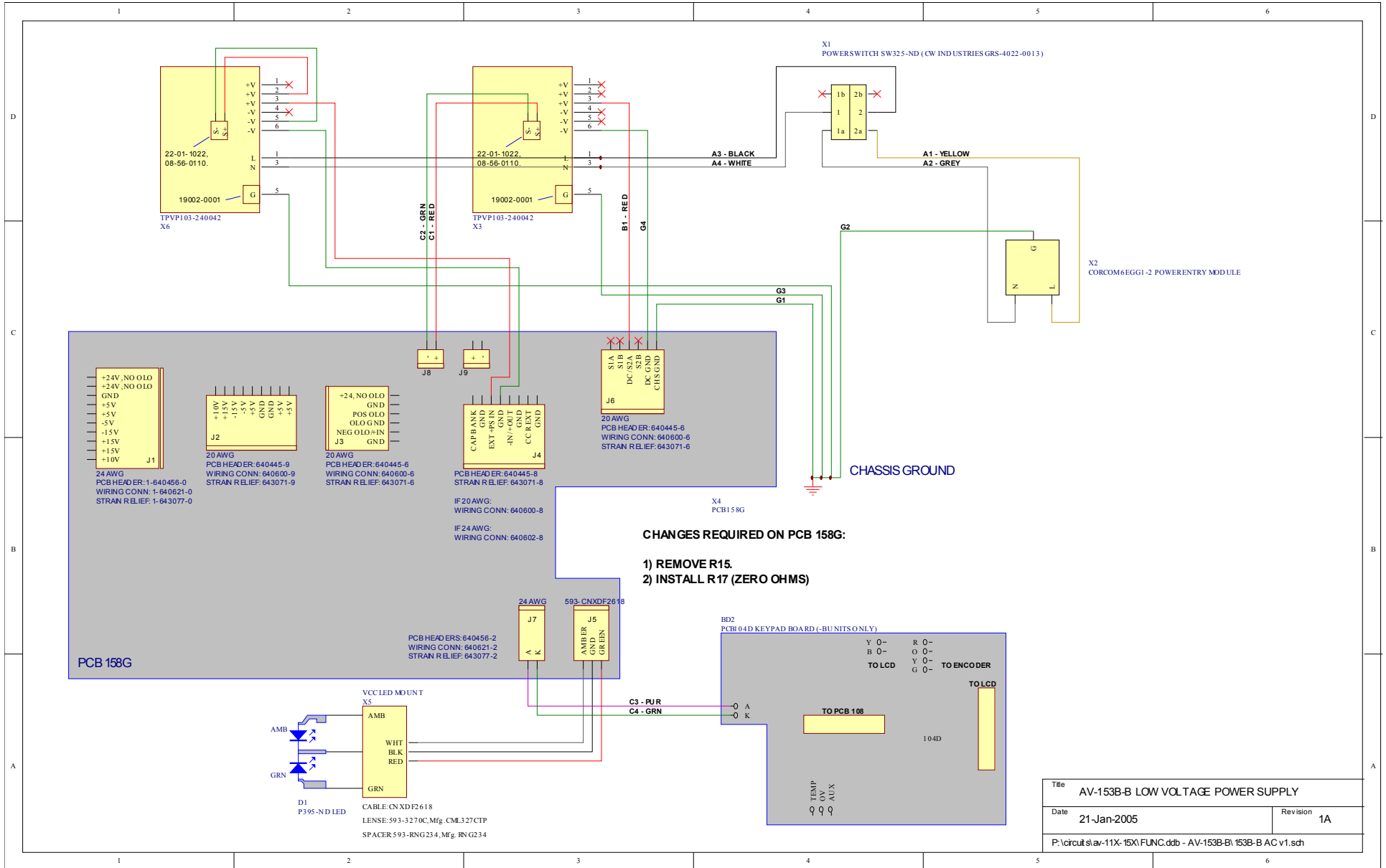

Title AV-153B-B LOW VOLTAGE POWER SUPPLY	
Date 21-Jan-2005	Revision 1A
P:\circuit\sl-ar-11X-15X\FUNC.ddb - AV-153B-B\153B-B AC v1.sch	

# PCB 158G - LOW VOLTAGE POWER SUPPLY, 1/3

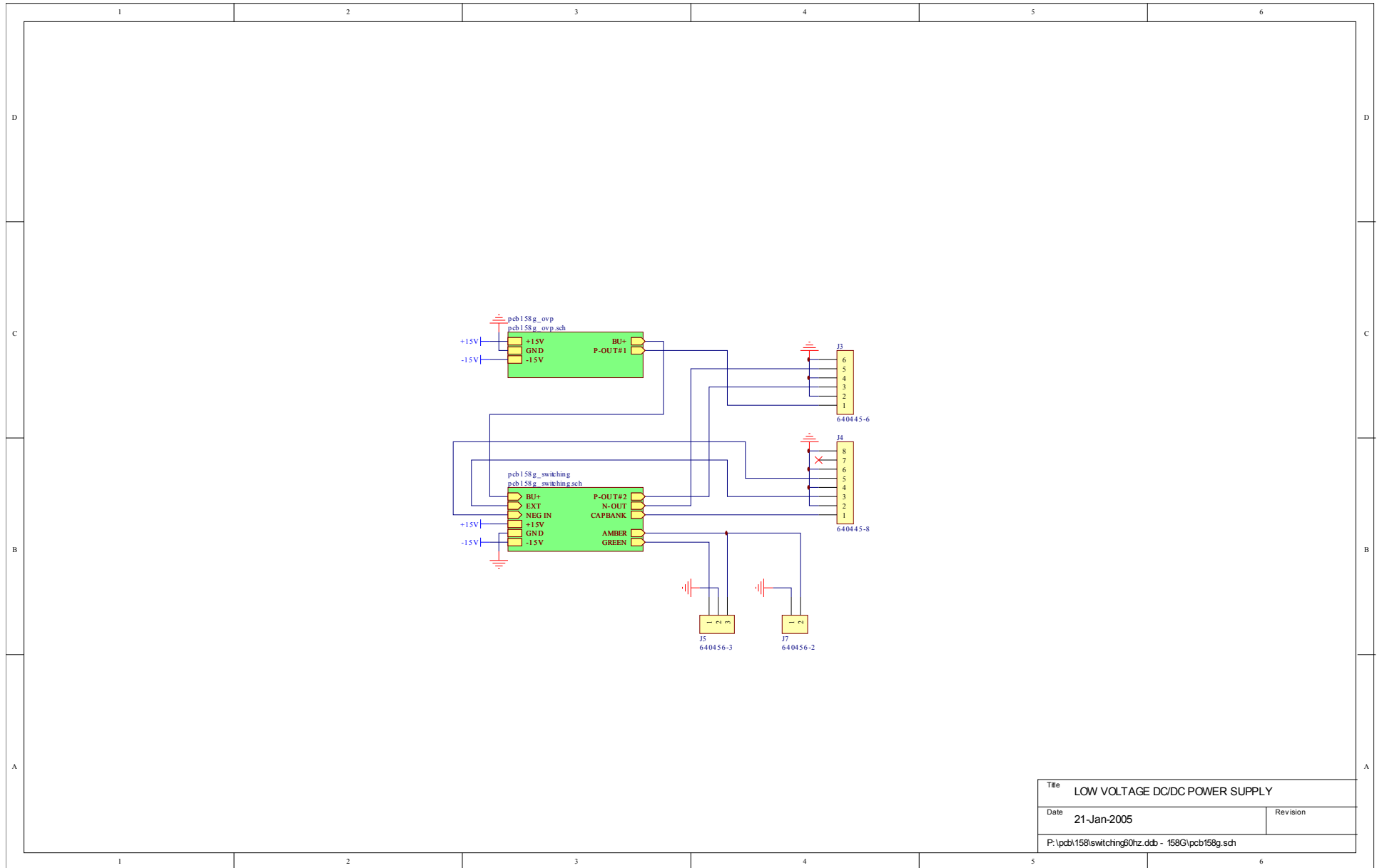

Title		LOW VOLTAGE DC/DC POWER SUPPLY
Date	21-Jan-2005	Revision
P:\pcb\158\switching60hz.ddb - 158G\pcb158g.sch		

# PCB 158G - LOW VOLTAGE POWER SUPPLY, 2/3

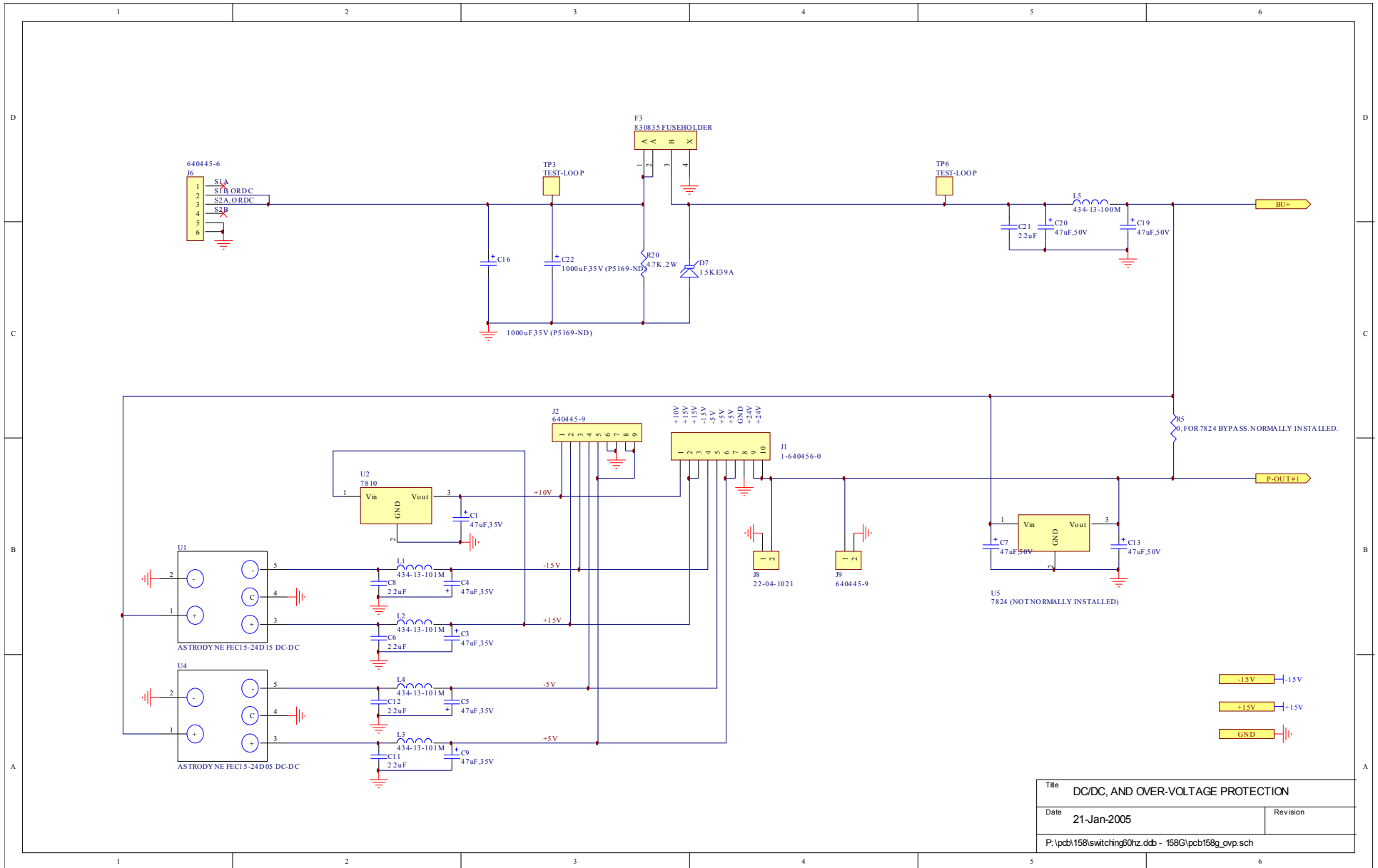



# PCB 158G - LOW VOLTAGE POWER SUPPLY, 3/3

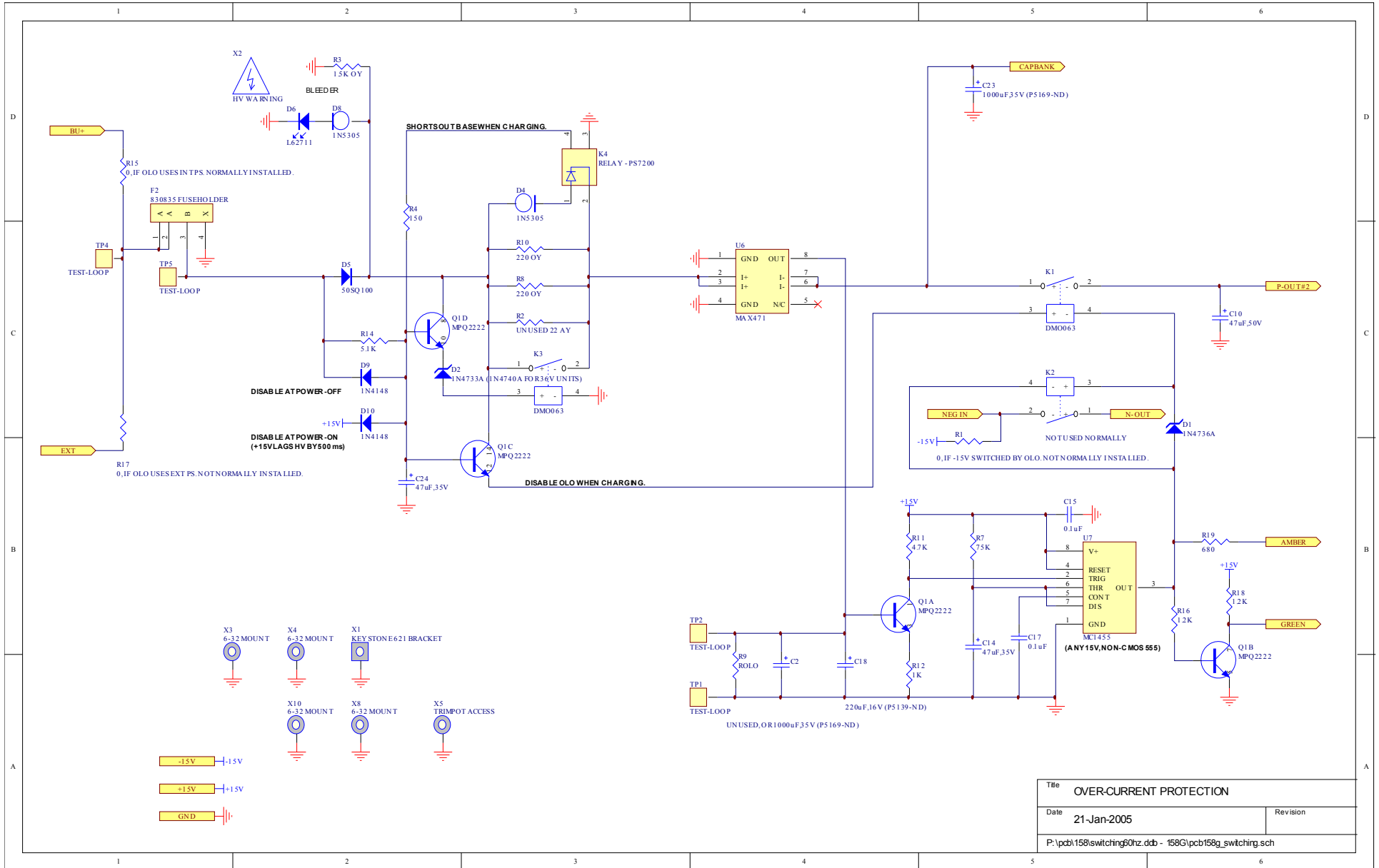





# PCB 104D - KEYPAD / DISPLAY BOARD, 1/3

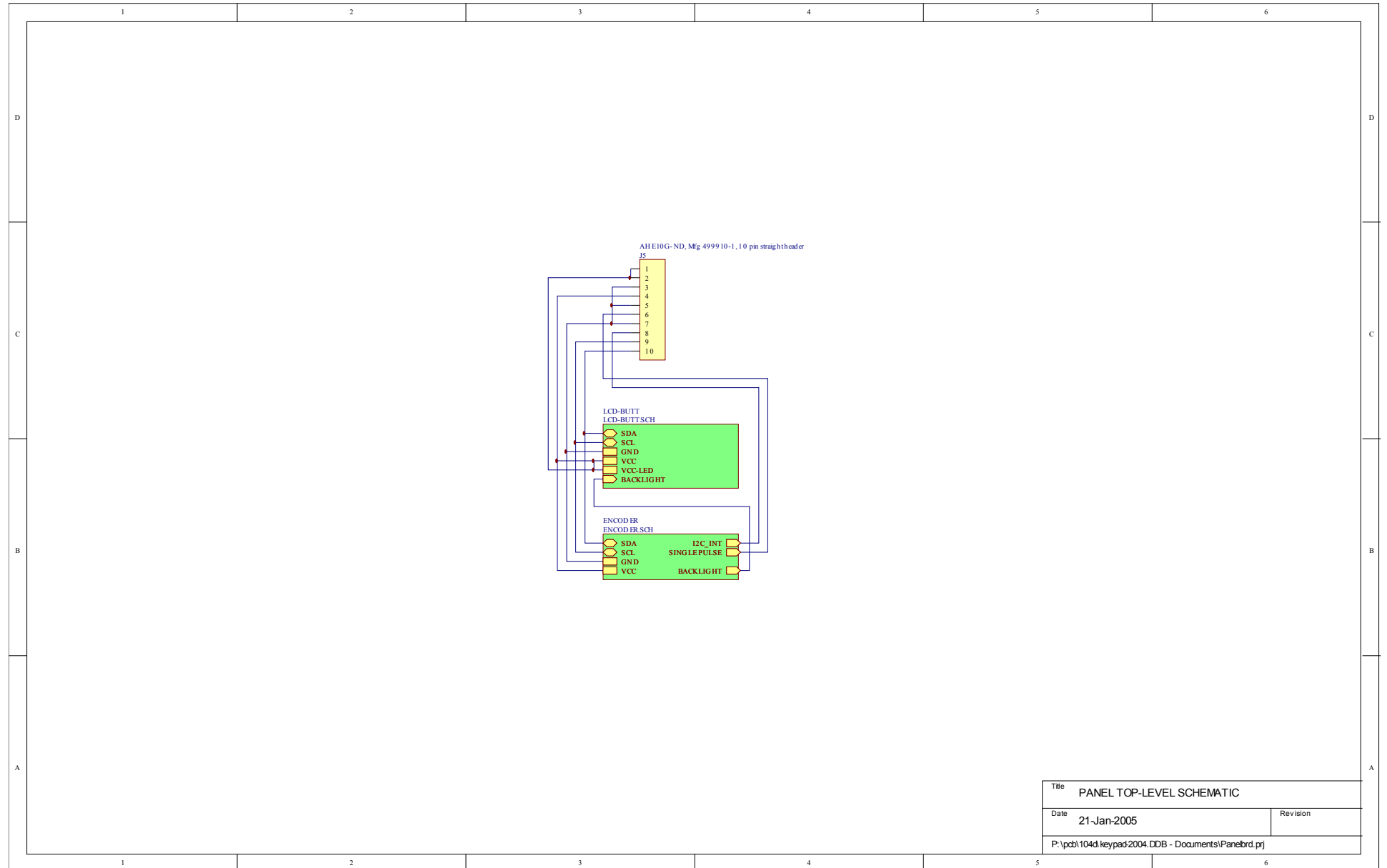

Title		PANEL TOP-LEVEL SCHEMATIC	
Date	21-Jan-2005	Revision	
P:\pcb\104d\keypad\2004.DDB - Documents\Panelbrd.prj			

# PCB 104D - KEYPAD / DISPLAY BOARD, 2/3

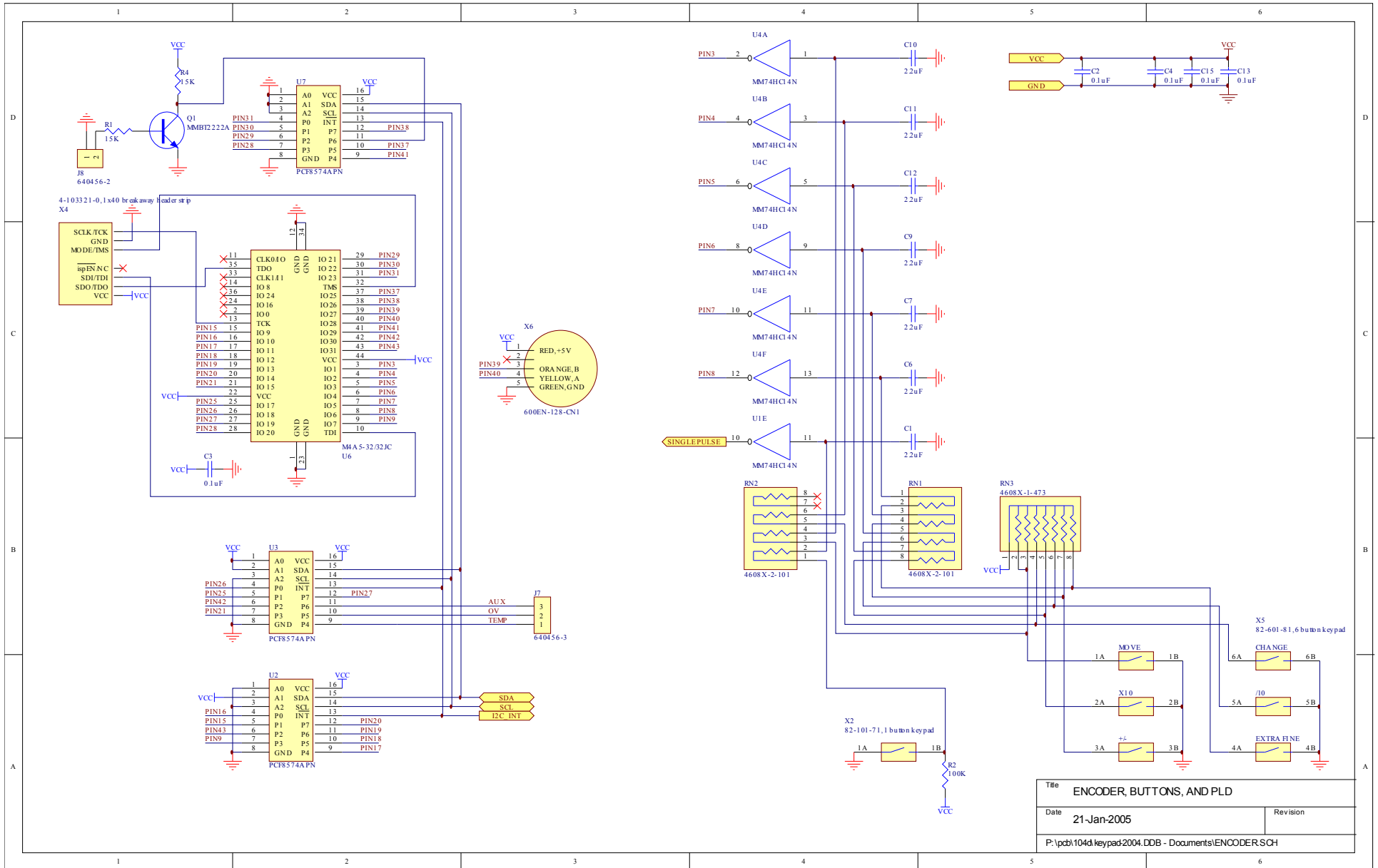

# PCB 104D - KEYPAD / DISPLAY BOARD, 3/3

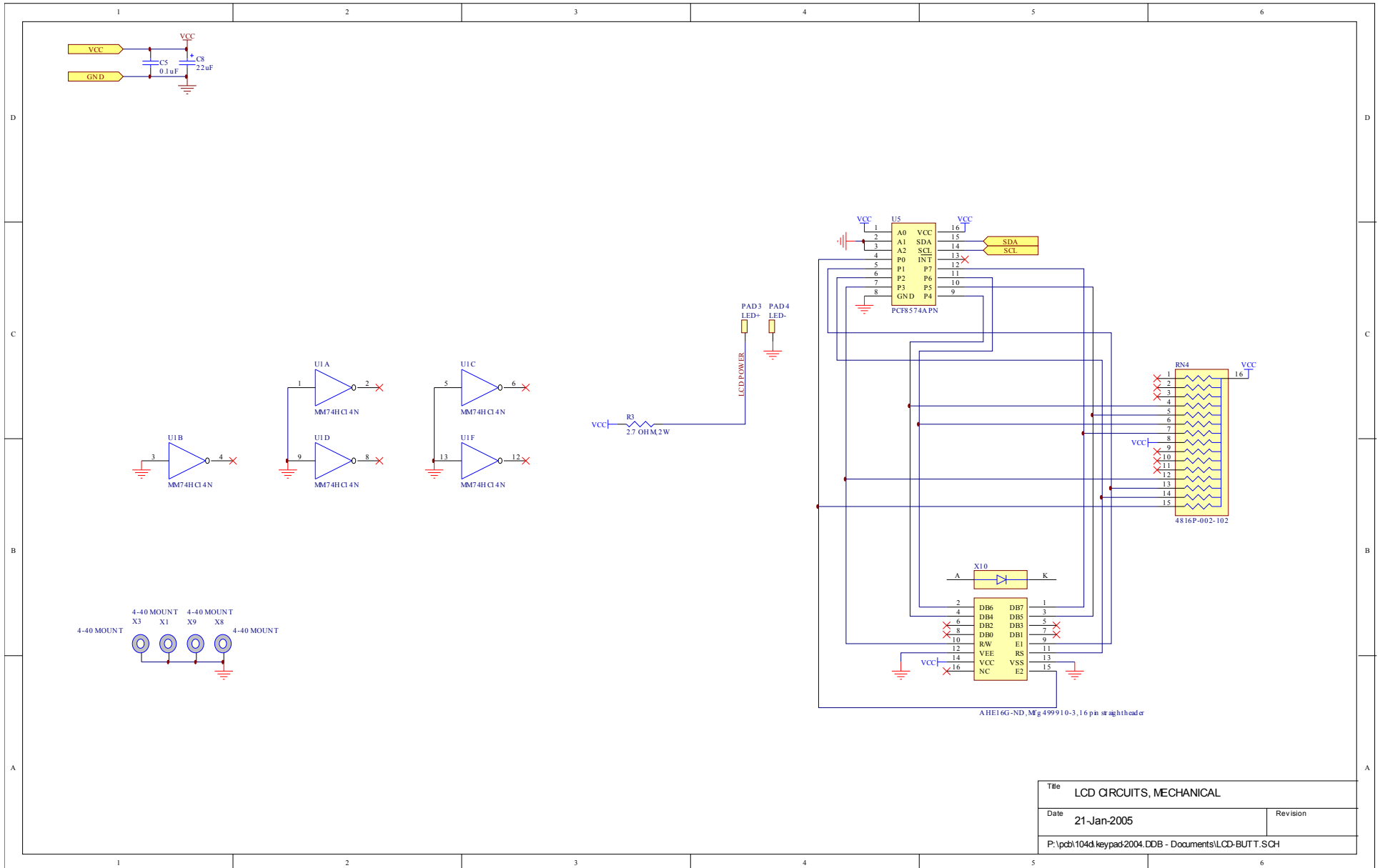

# WIRING OF TIMING BOARDS

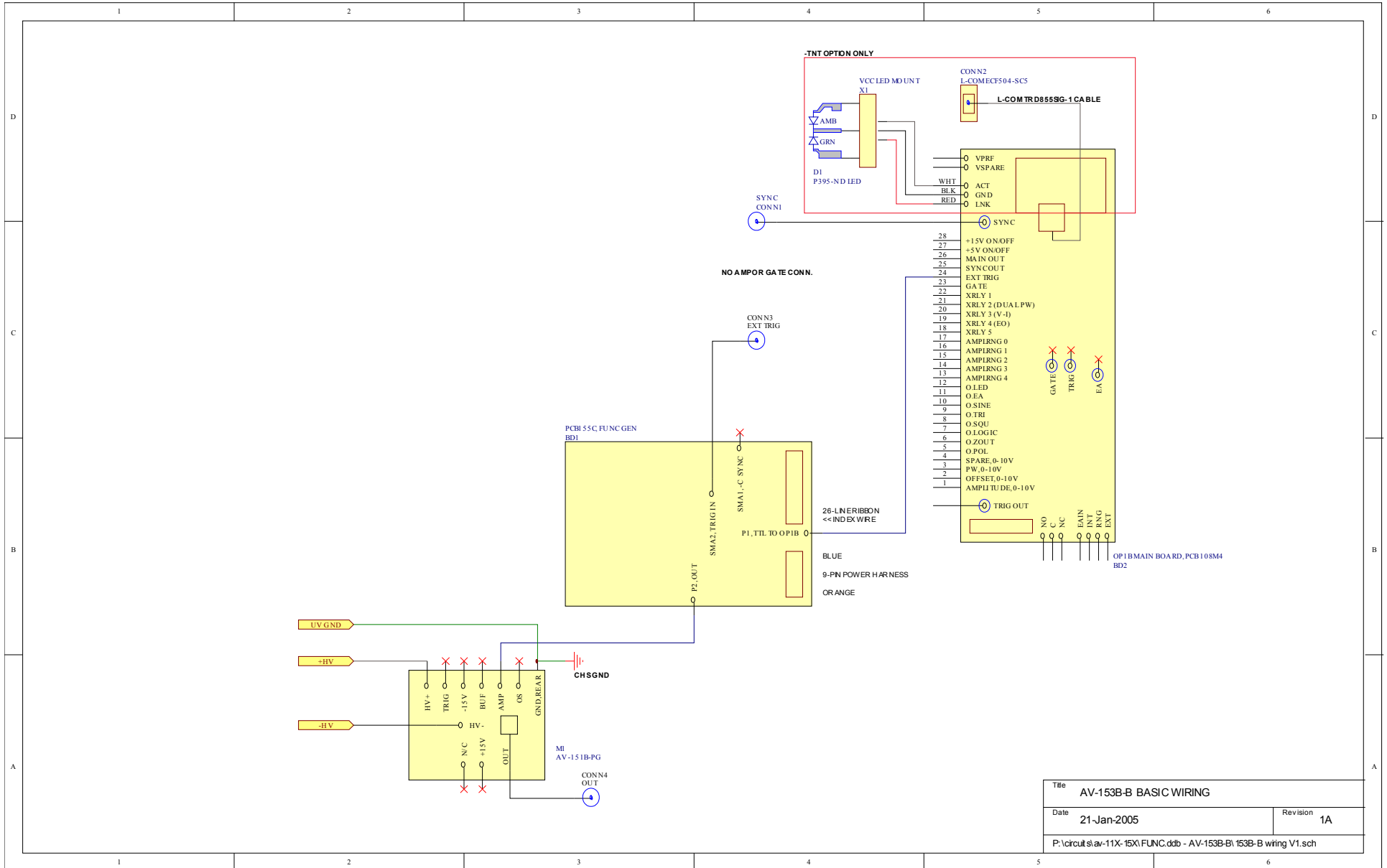

Title		AV-153B-B BASIC WIRING	
Date	21-Jan-2005	Revision	1A
P:\circuit\slav-11X-15X\FUNC.ddb - AV-153B-B\153B-B wiring V1.sch			

PERFORMANCE CHECK SHEET