



AVTECH ELECTROSYSTEMS LTD.

NANOSECOND WAVEFORM ELECTRONICS  
SINCE 1975

info@avtechpulse.com  
<http://www.avtechpulse.com/>

Tel: 888-670-8729 (USA & Canada)  
or +1-613-686-6675 (Worldwide)

BOX 5120, LCD MERIVALE  
OTTAWA, CANADA K2C3H5

## INSTRUCTIONS

MODEL AV-156E-B

10 mA to 5 A, 0 to +25 V, 10 us RISE TIME

DUAL CHANNEL

PULSED CONSTANT CURRENT GENERATOR

WITH IEEE 488.2 / RS-232 / ETHERNET CONTROL

SERIAL NUMBER: 14430

### WARRANTY

Avtech Electrosystems Ltd. warrants products of its manufacture to be free from defects in material and workmanship under conditions of normal use. If, within one year after delivery to the original owner, and after prepaid return by the original owner, this Avtech product is found to be defective, Avtech shall at its option repair or replace said defective item. This warranty does not apply to units which have been disassembled, modified or subjected to conditions exceeding the applicable specifications or ratings. This warranty is the extent of the obligation assumed by Avtech with respect to this product and no other warranty or guarantee is either expressed or implied.

### TECHNICAL SUPPORT

Phone: 888-670-8729 (USA & Canada)  
or +1-613-686-6675 (Worldwide)

E-mail: [info@avtechpulse.com](mailto:info@avtechpulse.com)  
World Wide Web: <http://www.avtechpulse.com>

## TABLE OF CONTENTS

<b>WARRANTY.....</b>	<b>2</b>
<b>TECHNICAL SUPPORT.....</b>	<b>2</b>
<b>TABLE OF CONTENTS.....</b>	<b>3</b>
<b>INTRODUCTION.....</b>	<b>5</b>
MODEL NUMBER HISTORY.....	5
<b>SPECIFICATIONS.....</b>	<b>6</b>
<b>REGULATORY NOTES.....</b>	<b>7</b>
FCC PART 18.....	7
EC DECLARATION OF CONFORMITY.....	7
DIRECTIVE 2011/65/EU (RoHS).....	8
DIRECTIVE 2002/96/EC (WEEE).....	8
FIRMWARE LICENSING.....	9
<b>INSTALLATION.....</b>	<b>10</b>
VISUAL CHECK.....	10
POWER RATINGS.....	10
CONNECTION TO THE POWER SUPPLY.....	10
PROTECTION FROM ELECTRIC SHOCK.....	11
ENVIRONMENTAL CONDITIONS.....	12
<b>FUSES.....</b>	<b>13</b>
AC FUSE REPLACEMENT.....	13
DC FUSE REPLACEMENT.....	14
FUSE RATINGS.....	14
<b>FRONT PANEL CONTROLS.....</b>	<b>15</b>
<b>REAR PANEL CONTROLS.....</b>	<b>17</b>
<b>GENERAL INFORMATION.....</b>	<b>19</b>
BASIC PULSE CONTROL.....	19
MONITOR CIRCUIT.....	20
TRIGGER MODES.....	20
GATING MODES.....	21
<b>LOAD PROTECTION.....</b>	<b>22</b>
LENZ'S LAW AND INDUCTIVE VOLTAGE SPIKES.....	22
OSCILLATIONS ON THE OUTPUT.....	22
OUTPUT ON/OFF.....	22
ATTACHING AND DETACHING LOADS.....	22

- OPEN AND SHORT CIRCUITS.....23
- OPERATIONAL CHECK.....24**
- CALIBRATION.....27**
  - TIMING CALIBRATION.....27
  - AMPLITUDE CALIBRATION.....27
  - CURRENT MONITOR CALIBRATION.....27
- PROGRAMMING YOUR PULSE GENERATOR.....29**
  - KEY PROGRAMMING COMMANDS.....29
  - ALL PROGRAMMING COMMANDS.....29
- MECHANICAL INFORMATION.....32**
  - TOP COVER REMOVAL.....32
  - RACK MOUNTING.....32
  - ELECTROMAGNETIC INTERFERENCE.....32
- MAINTENANCE.....33**
  - REGULAR MAINTENANCE.....33
  - CLEANING.....33
  - TRIGGER DAMAGE.....33
- WIRING DIAGRAMS.....34**
  - WIRING OF AC POWER.....34
  - WIRING OF DC POWER.....35
  - PCB 158R4 - LOW VOLTAGE POWER SUPPLY.....36
  - PCB 174B - DUAL PW PCB.....37
  - PCB 116D - CURRENT MONITOR BOARD.....38
  - PCB 226B - SELF-CALIBRATION.....39
  - PCB 104H - KEYPAD / DISPLAY BOARD.....40
  - MAIN SIGNAL WIRING.....41
- PERFORMANCE CHECK SHEET.....42**

## INTRODUCTION

The Model AV-156E-B pulsed constant current generator is capable of producing two channels of rectangular pulses with amplitudes as high as 5 Amperes into load voltages up to 25V, with < 10 us rise and fall times. The internal trigger source can be used to trigger the instrument at frequencies between 1 and 100 Hz. An external TTL trigger pulse, a front-panel pushbutton, and a computer can also be used to trigger the instrument. The maximum duty cycle is 10%.

This instrument has two output channels. The pulses on one channel may be delayed up to  $\pm 1000$  ms with respect to the pulses on the other channel.

The Model AV-156E-B pulse generator is a current pulser. The current amplitude is largely independent of the load voltage. For proper operation, the load voltage ( $V_{LOAD} = I_{LOAD} \times R_{LOAD}$ ) must lie in the range of 0 to +25V.

The AV-156E-B features front panel keyboard and adjust knob control of the output pulse parameters along with a four line by 40-character backlit LCD display of the output amplitude, pulse width, pulse repetition frequency, and delay. The instrument includes memory to store up to four complete instrument setups. The operator may use the front panel or the computer interface to store a complete "snapshot" of all key instrument settings, and recall this setup at a later time.

This instrument is intended for use in research, development, test and calibration laboratories by qualified personnel.

## MODEL NUMBER HISTORY

Models AV-156E-B and AV-156A-C-P-OP1B-ISIA are equivalent. These model numbers may be used interchangeably. The AV-156A-C-P-OP1B-ISIA was originally developed as a special-order model. It was later added as a standard product in the Avtech catalog, and renamed the "AV-156E-B".

## SPECIFICATIONS

Model:	AV-156E-B
Amplitude:	0.01 - 5.0 A
Number of output channels:	Two, with independent control of amplitude and pulse width.
Pulse width (FWHM):	1 to 100 ms
Max. pulse repetition freq:	100 Hz
Max. duty cycle:	10%
Rise & fall time <sup>1</sup> (20%-80%):	< 10 us
Load configuration:	Referenced to ground.
Polarity:	Positive - sources current.
Output current regulation:	< 2 % load voltage change from 0 Volts to maximum rated voltage
Load voltage range:	0 to +25V
Overshoot <sup>4</sup> :	< 10 %
Jitter:	< $\pm 200$ ps $\pm 0.03\%$ of sync delay (Ext trig in to pulse out)
Trigger required:	External trigger mode: TTL, PW > 50 ns
Sync delay: (Sync out to pulse out)	Channel 1: 0 to 1.0 seconds Channel 2: 0 (fixed)
Sync output:	+3 Volts, 100 ns, will drive 50 Ohm loads
Amplitude accuracy <sup>1,5</sup> :	$\pm 3$ mA $\pm 3\%$
Frequency accuracy <sup>5</sup> :	$\pm 3\%$
Pulse width accuracy <sup>1,5</sup> :	$\pm 1$ us $\pm 3\%$
Sync delay accuracy <sup>1,5</sup> :	$\pm 1$ us $\pm 3\%$
Gate input:	Active high or low, switchable. Suppresses triggering when active.
Monitor output:	Back-panel BNC connector provides a coincident replica of the output current.
Connectors, main output:	BNC, front-panel <sup>6</sup>
Connectors, other:	Sync output: BNC, front-panel. Gate, Ext Trig, Monitor: BNC, rear-panel
GPIB and RS-232 control:	Standard feature. See page See <a href="http://www.avtechpulse.com/gpib">http://www.avtechpulse.com/gpib</a> for details.
LabView Drivers:	Check <a href="http://www.avtechpulse.com/labview">http://www.avtechpulse.com/labview</a> for availability and downloads
Ethernet port, for remote control using VXI-11.3, ssh, telnet, & web:	Included. Recommended as a modern alternative to GPIB / RS-232. See <a href="http://www.avtechpulse.com/options/vxi">http://www.avtechpulse.com/options/vxi</a> for details.
Power requirements:	100 - 240 Volts, 50 - 60 Hz
Dimensions: (H x W x D)	100 mm x 430 mm x 425 mm (3.9" x 17" x 16.8")
Chassis material:	cast aluminum frame & handles, blue vinyl on aluminum cover plates
Temperature range:	+5°C to +40°C

1) Valid when driving a load impedance that is between zero Ohms and the impedance given by (Maximum Compliance Voltage) / (Maximum Rated Current). For load impedances higher than this value, de-rate the rise and fall times proportionally.

2) To specify the high compliance voltage option, add the suffix -HC to the model number.

3) To specify the voltage-to-current amplifier mode option, add the suffix -VI to the model number.

4) Valid for amplitudes greater than 5% of the full-scale value, into non-inductive loads.

5) At room temperature after 10 minute warmup, when operating into a resistive load.

6) To add a duplicate main output connector on the rear panel, add the suffix -RP to the model number.

## REGULATORY NOTES

### FCC PART 18

This device complies with part 18 of the FCC rules for non-consumer industrial, scientific and medical (ISM) equipment.

This instrument is enclosed in a rugged metal chassis and uses a filtered power entry module (where applicable). The main output signal is provided on a shielded connector that is intended to be used with shielded coaxial cabling and a shielded load. Under these conditions, the interference potential of this instrument is low.

If interference is observed, check that appropriate well-shielded cabling is used on the output connectors. Contact Avtech ([info@avtechpulse.com](mailto:info@avtechpulse.com)) for advice if you are unsure of the most appropriate cabling. Also, check that your load is adequately shielded. It may be necessary to enclose the load in a metal enclosure.

If any of the connectors on the instrument are unused, they should be covered with shielded metal “dust caps” to reduce the interference potential.

This instrument does not normally require regular maintenance to minimize interference potential. However, if loose hardware or connectors are noted, they should be tightened. Contact Avtech ([info@avtechpulse.com](mailto:info@avtechpulse.com)) if you require assistance.

### EC DECLARATION OF CONFORMITY



We                      Avtech Electrosystems Ltd.  
                             P.O. Box 5120, LCD Merivale  
                             Ottawa, Ontario  
                             Canada K2C 3H5

declare that this pulse generator meets the intent of Directive 2014/30/EU for Electromagnetic Compatibility. Compliance pertains to the following specifications as listed in the official Journal of the European Communities:

EN 50081-1 Emission

EN 50082-1 Immunity

and that this pulse generator meets the intent of the Low Voltage Directive 2014/35/EU. Compliance pertains to the following specifications as listed in the official Journal of the European Communities:

EN 61010-1:2010+A1:2019, Safety requirements for electrical equipment for measurement, control, and laboratory use

#### DIRECTIVE 2011/65/EU (RoHS)

We Avtech Electrosystems Ltd.  
P.O. Box 5120, LCD Merivale  
Ottawa, Ontario  
Canada K2C 3H5

declare that, to the best of our knowledge, all electrical and electronic equipment (EEE) sold by the company are in compliance with Directive 2011/65/EU of the European Parliament and of the Council of 8 June 2011 on the restriction of the use of certain hazardous substances in electrical and electronic equipment (also known as “RoHS Recast”). In addition, this declaration of conformity is issued under the sole responsibility of Avtech Electrosystems Ltd. Specifically, products manufactured do not contain the substances listed in the table below in concentrations greater than the listed maximum value.

<i>Material/Substance</i>	<i>Threshold level</i>
Lead (Pb)	< 1000 ppm (0.1% by mass)
Mercury (Hg)	< 1000 ppm (0.1% by mass)
Hexavalent Chromium (Cr6+)	< 1000 ppm (0.1% by mass)
Polybrominated Biphenyls (PBB)	< 1000 ppm (0.1% by mass)
Polybrominated Diphenyl ethers (PBDE)	< 1000 ppm (0.1% by mass)
Cadmium (Cd)	< 100 ppm (0.01% by mass)
Bis(2-ethylhexyl) phthalate (DEHP)	< 1000 ppm (0.1% by mass)
Butyl benzyl phthalate (BBP)	< 1000 ppm (0.1% by mass)
Dibutyl phthalate (DBP)	< 1000 ppm (0.1% by mass)
Diisobutyl phthalate (DIBP)	< 1000 ppm (0.1% by mass)

#### DIRECTIVE 2002/96/EC (WEEE)

European customers who have purchased this equipment directly from Avtech will have completed a “WEEE Responsibility Agreement” form, accepting responsibility for WEEE compliance (as mandated in Directive 2002/96/EC of the European Union and local laws) on behalf of the customer, as provided for under Article 9 of Directive 2002/96/EC.



Customers who have purchased Avtech equipment through local representatives should consult with the representative to determine who has responsibility for WEEE compliance. Normally, such responsibilities will lie with the representative, unless other arrangements (under Article 9) have been made.

Requirements for WEEE compliance may include registration of products with local governments, reporting of recycling activities to local governments, and financing of recycling activities.

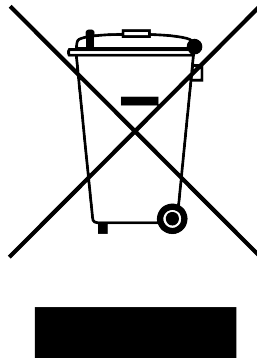

### FIRMWARE LICENSING

Instruments with firmware versions 5.00 or higher use open-source software internally. Some of this software requires that the source code be made available to the user as a condition of its licensing. This source code is available upon request (contact [info@avtechpulse.com](mailto:info@avtechpulse.com)).

Earlier firmware versions do not contain any open source software.

## INSTALLATION

### VISUAL CHECK

After unpacking the instrument, examine to ensure that it has not been damaged in shipment. Visually inspect all connectors, knobs, liquid crystal displays (LCDs), and the handles. Confirm that a power cord, a GPIB cable, and two instrumentation manuals (this manual and the “Programming Manual for -B Instruments”) are with the instrument. If the instrument has been damaged, file a claim immediately with the company that transported the instrument.

### POWER RATINGS

This instrument is intended to operate from 100 - 240 V, 50 - 60 Hz.

The maximum power consumption is 115 Watts. Please see the “FUSES” section for information about the appropriate AC and DC fuses.

This instrument is an “Installation Category II” instrument, intended for operation from a normal single-phase supply.

### CONNECTION TO THE POWER SUPPLY

An IEC-320 three-pronged recessed male socket is provided on the back panel for AC power connection to the instrument. One end of the detachable power cord that is supplied with the instrument plugs into this socket. The other end of the detachable power cord plugs into the local mains supply. Use only the cable supplied with the instrument. The mains supply must be earthed, and the cord used to connect the instrument to the mains supply must provide an earth connection. (The supplied cord does this.)

 Warning: Failure to use a grounded outlet may result in injury or death due to electric shock. This product uses a power cord with a ground connection. It must be connected to a properly grounded outlet. The instrument chassis is connected to the ground wire in the power cord.

The table below describes the power cord that is normally supplied with this instrument, depending on the destination region:

Destination Region	Description	Option	Manufacturer	Part Number
United Kingdom, Hong Kong, Singapore, Malaysia	BS 1363, 230V, 50 Hz	-AC00	Qualtek	370001-E01
Australia, New Zealand	AS 3112:2000, 230-240V, 50 Hz	-AC01	Qualtek	374003-A01
Continental Europe, Korea, Indonesia, Russia	European CEE 7/7 "Schuko" 230V, 50 Hz	-AC02	Qualtek	364002-D01
North America, Taiwan	NEMA 5-15, 120V, 60 Hz	-AC03	Qualtek	312007-01
Switzerland	SEV 1011, 230V, 50 Hz	-AC06	Qualtek	378001-E01
South Africa, India	SABS 164-1, 220-250V, 50 Hz	-AC17	Volex	2131H 10 C3
Japan	JIS 8303, 100V, 50-60 Hz	-AC18	Qualtek	397002-01
Israel	SI 32, 220V, 50 Hz	-AC19	Qualtek	398001-01
China	GB 1002-1 / 2099-1, 220V, 50 Hz	-AC22	Qualtek	399012-01

## PROTECTION FROM ELECTRIC SHOCK

 Operators of this instrument must be protected from electric shock at all times. The owner must ensure that operators are prevented access and/or are insulated from every connection point. In some cases, connections must be exposed to potential human contact. Operators must be trained to protect themselves from the risk of electric shock. This instrument is intended for use by qualified personnel who recognize shock hazards and are familiar with safety precautions required to avoid possibly injury. In particular, operators should:

1. Keep exposed high-voltage wiring to an absolute minimum.
2. Wherever possible, use shielded connectors and cabling.
3. Connect and disconnect loads and cables only when the instrument is turned off.
4. Keep in mind that all cables, connectors, oscilloscope probes, and loads must have an appropriate voltage rating.
5. Do not attempt any repairs on the instrument, beyond the fuse replacement procedures described in this manual. Contact Avtech technical support (see page 2 for contact information) if the instrument requires servicing. Service is to be performed solely by qualified service personnel.

## ENVIRONMENTAL CONDITIONS

This instrument is intended for use under the following conditions:

1. indoor use;
2. altitude up to 2 000 m;
3. temperature 5 °C to 40 °C;
4. maximum relative humidity 80 % for temperatures up to 31 °C decreasing linearly to 50 % relative humidity at 40 °C;
5. Mains supply voltage fluctuations up to  $\pm 10$  % of the nominal voltage;
6. no pollution or only dry, non-conductive pollution.

## FUSES

This instrument contains four fuses. All are accessible from the rear-panel. Two protect the AC prime power input, and two protect the internal DC power supplies. The locations of the fuses on the rear panel are shown in the figure below:

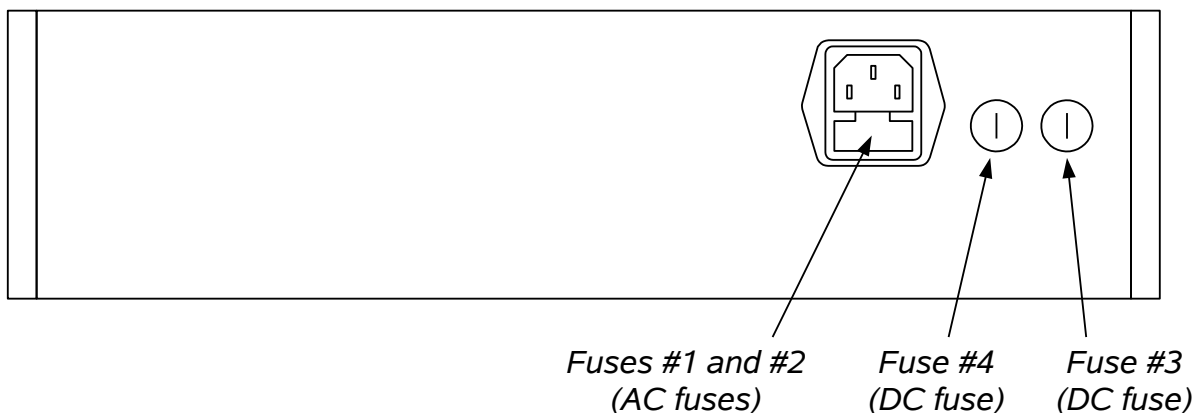

### AC FUSE REPLACEMENT

To physically access the AC fuses, the power cord must be detached from the rear panel of the instrument. The fuse drawer may then be extracted using a small flat-head screwdriver, as shown below:

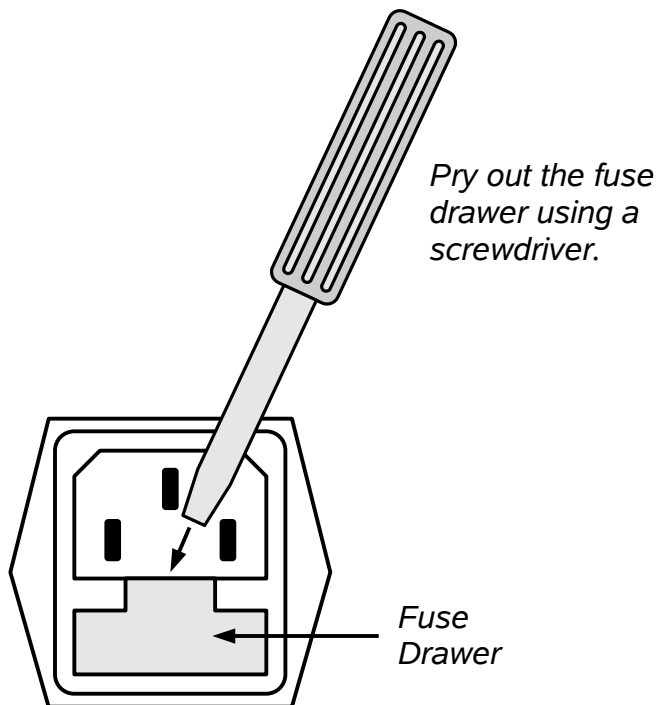

## DC FUSE REPLACEMENT

The DC fuses may be replaced by inserting the tip of a flat-head screwdriver into the fuse holder slot, and rotating the slot counter-clockwise. The fuse and its carrier will then pop out.

## FUSE RATINGS

The following table lists the required fuses:

Fuses	Nominal Mains Voltage	Rating	Case Size	Recommended Replacement Part	
				Littelfuse Part Number	Digi-Key Stock Number
#1, #2 (AC)	115 V	1.0A, 250V, Time-Delay	5×20 mm	0218001.HXP	F2419-ND
	230 V	0.5A, 250V, Time-Delay	5×20 mm	0218.500HXP	F2416-ND
#3 (DC)	N/A	1.0A, 250V, Time-Delay	5×20 mm	0218001.HXP	F2419-ND
#4 (DC)	N/A	2.0A, 250V, Time-Delay	5×20 mm	0218002.HXP	F2420-ND

The recommended fuse manufacturer is Littelfuse (<http://www.littelfuse.com>).

Replacement fuses may be easily obtained from Digi-Key (<http://www.digikey.com>) and other distributors.

## FRONT PANEL CONTROLS

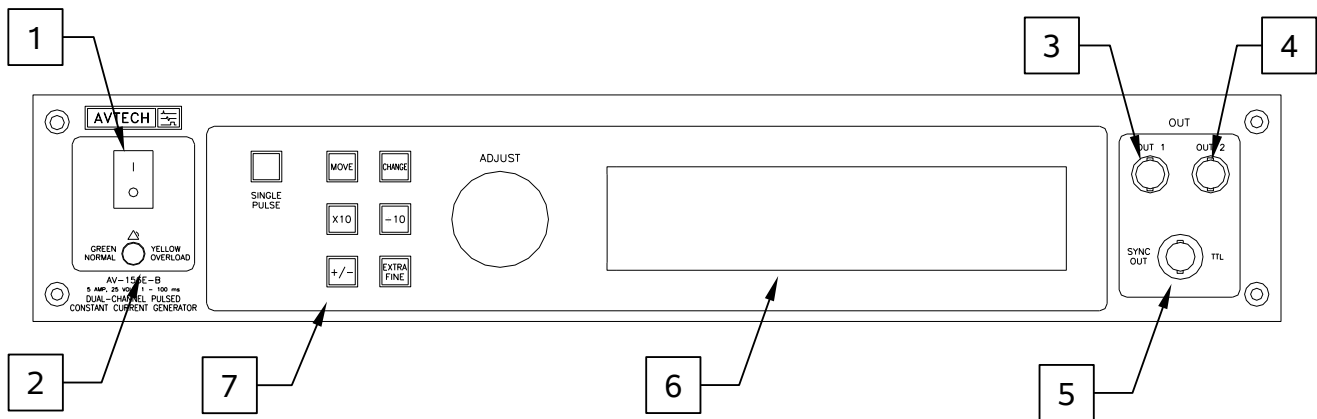

1. POWER Switch. This is the main power switch. When turning the instrument on, there is normally a delay of 10 seconds before anything is shown on the main display, as the internal operating system boots up.
2. OVERLOAD Indicator. When the instrument is powered, this indicator is normally green, indicating normal operation. If this indicator is yellow, an internal automatic overload protection circuit has been tripped. If the unit is overloaded (by operating at an exceedingly high duty cycle or by operating into a very low impedance), the protective circuit will disable the output of the instrument and turn the indicator light yellow. The light will stay yellow (i.e. output disabled) for about 5 seconds after which the instrument will attempt to re-enable the output (i.e. light green) for about 1 second. If the overload condition persists, the output will be disabled again (i.e. light yellow) for another 5 seconds. If the overload condition has been removed, the instrument will resume normal operation.

This overload indicator may flash yellow briefly at start-up. This is not a cause for concern.

3. OUT 1 CONNECTOR. This BNC connector provides the Channel 1 output signal.
4. OUT 2 CONNECTOR. This BNC connector provides the Channel 2 output signal.
5. SYNC OUT. This connector supplies a SYNC output that can be used to trigger other equipment, particularly oscilloscopes. This pulse is coincident with pulses on Channel 2. The sync output has an approximate amplitude of +3 Volts to  $R_L > 1\text{ k}\Omega$  with a pulse width of approximately 100 ns.
6. LIQUID CRYSTAL DISPLAY (LCD). This LCD is used in conjunction with the keypad to change the instrument settings. Normally, the main menu is displayed, which lists the key adjustable parameters and their current values. The "Programming Manual for -B Instruments" describes the menus and submenus in detail.

7. KEYPAD.

Control Name	Function
MOVE	This moves the arrow pointer on the display.
CHANGE	This is used to enter the submenu, or to select the operating mode, pointed to by the arrow pointer.
×10	If one of the adjustable numeric parameters is displayed, this increases the setting by a factor of ten.
÷10	If one of the adjustable numeric parameters is displayed, this decreases the setting by a factor of ten.
+/-	If one of the adjustable numeric parameters is displayed, and this parameter can be both positive or negative, this changes the sign of the parameter.
EXTRA FINE	This changes the step size of the ADJUST knob. In the extra-fine mode, the step size is twenty times finer than in the normal mode. This button switches between the two step sizes.
ADJUST	This large knob adjusts the value of any displayed numeric adjustable values, such as frequency, pulse width, etc. The adjust step size is set by the "EXTRA FINE" button.  When the main menu is displayed, this knob can be used to move the arrow pointer.



## REAR PANEL CONTROLS

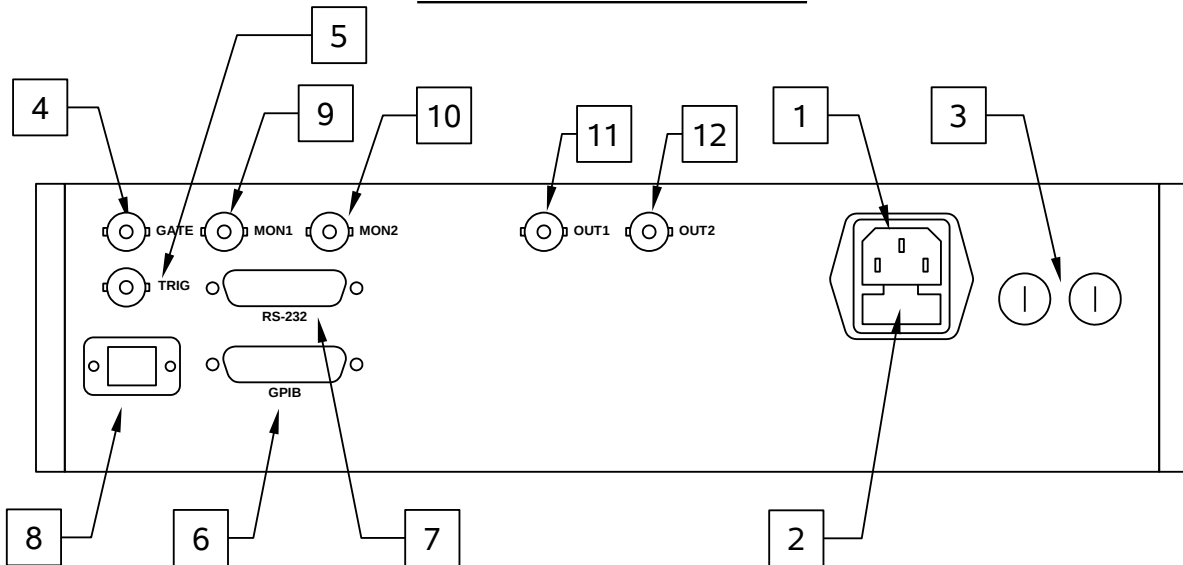

*Note: some connectors may be in different positions than shown above, depending on the exact combination of options ordered.*

1. AC POWER INPUT. An IEC-320 C14 three-pronged recessed male socket is provided on the back panel for AC power connection to the instrument. One end of the detachable power cord that is supplied with the instrument plugs into this socket.
2. AC FUSE DRAWER. The two fuses that protect the AC input are located in this drawer. Please see the “FUSES” section of this manual for more information.
3. DC FUSES. These two fuses protect the internal DC power supplies. Please see the “FUSES” sections of this manual for more information.
4. GATE. This TTL-level (0 and +5V) logic input can be used to gate the triggering of the instrument. This input can be either active high or active low, depending on the front panel settings or programming commands. (The instrument triggers normally when this input is unconnected). When set to active high mode, this input is pulled-down to ground by a 1 k $\Omega$  resistor. When set to active low mode, this input is pulled-up to +5V by a 1 k $\Omega$  resistor.
5. TRIG. This TTL-level (0 and +5V) logic input can be used to trigger the instrument, if the instrument is set to triggering externally. The instrument triggers on the rising edge of this input. The input impedance of this input is 1 k $\Omega$ . (Depending on the length of cable attached to this input, and the source driving it, it may be desirable to add a coaxial 50 Ohm terminator to this input to provide a proper transmission line termination. The Pasternack ([www.pasternack.com](http://www.pasternack.com)) PE6008-50 BNC feed-thru 50 Ohm terminator is suggested for this purpose.)
6. GPIB Connector. A standard GPIB cable can be attached to this connector to allow the instrument to be computer-controlled. See the “Programming Manual for -B

Instruments” for more details on GPIB control.

7. RS-232 Connector. A standard serial cable with a 25-pin male connector can be attached to this connector to allow the instrument to be computer-controlled. A user name (“admin”) and a password (“default”, as shipped from the factory) are required when logging into a serial terminal session. The internal controller attempts to auto-sense the parity setting. It may be necessary to send a few return characters before attempting a login in order to provide enough data to allow this auto-sensing to work. (A standard Linux “agetty” process is used to implement serial control internally.) See the “Programming Manual for -B Instruments” for more details on RS-232 control.
8. Network Connector. This Ethernet connector allows the instrument to be remotely controlled using the VXI-11.3, ssh (secure shell), telnet, and http (web) protocols. See the “Programming Manual for -B Instruments” for more details.
9. MON1. This is a current monitor output. This output provides a voltage waveform that is proportional to the current waveform on the Channel 1 output. The monitor relationship is:  $V_{MON} = I_{OUT} \times 1\Omega$ , for a load of  $> 1\text{ k}\Omega$ . (The monitor output can also drive a  $50\Omega$  load, but the output voltage will be reduced by a factor of two. This output is short-circuit protected.) This connector may be in a slightly different location, depending on the options ordered.
10. MON2. This is a current monitor output. This output provides a voltage waveform that is proportional to the current waveform on the Channel 2 output. The monitor relationship is:  $V_{MON} = I_{OUT} \times 1\Omega$ , for a load of  $> 1\text{ k}\Omega$ . (The monitor output can also drive a  $50\Omega$  load, but the output voltage will be reduced by a factor of two. This output is short-circuit protected.) This connector may be in a slightly different location, depending on the options ordered.
11. OUT 1 CONNECTOR. (Optional. Present on -RP units only). This BNC connector provides the Channel 1 output signal. The front panel and rear panel “OUT 1” connectors are wired to the same location internally, and may be used interchangeably.
12. OUT 2 CONNECTOR. (Optional. Present on -RP units only). This BNC connector provides the Channel 2 output signal. The front panel and rear panel “OUT 2” connectors are wired to the same location internally, and may be used interchangeably.

## GENERAL INFORMATION

### BASIC PULSE CONTROL

This instrument can be triggered by several sources - its own internal clock, an external TTL trigger signal, the front-panel "SINGLE PULSE" pushbutton, or by a computer-generated command. In any case, five output channels respond to the trigger: OUT1, OUT2, SYNC, MON1, and MON2. OUT1 and OUT2 are the signals that are applied to the devices under test. Their amplitudes and pulse widths are variable. The SYNC pulse is a fixed-width TTL-level reference pulse used to trigger oscilloscopes or other measurement systems, and is coincident with the OUT2 pulse. The MON1 and MON2 outputs are voltage waveforms that are proportional to the current waveforms on OUT1 and OUT2, respectively.  $V_{MON1} = I_{OUT1} \times 1\Omega$  and  $V_{MON2} = I_{OUT2} \times 1\Omega$  for monitor loads of  $> 1\text{ k}\Omega$ .

When the delay is set to a positive value the OUT2 and SYNC pulses precede the channel 1 pulse. This order is reversed for negative delays.

These pulses are illustrated below for a positive delay:

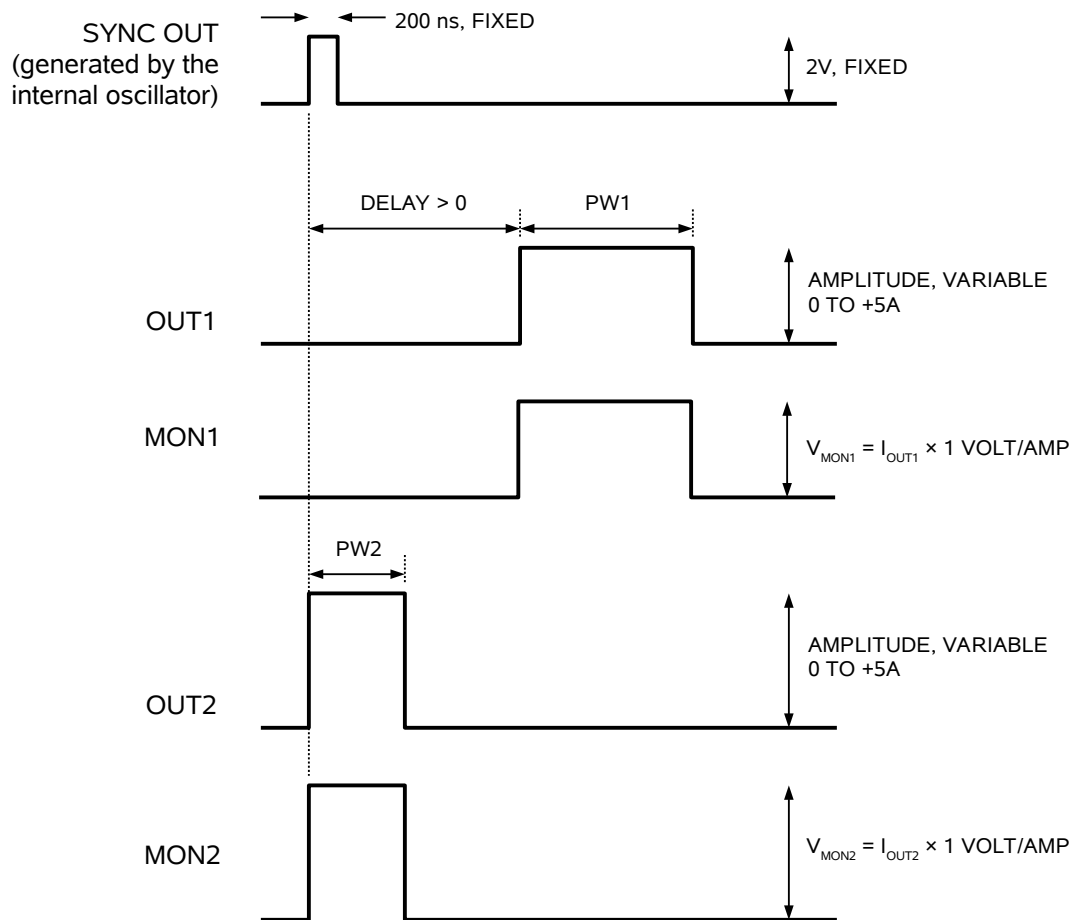

*Basic Output Pulses for Delay > 0*

The order of the output pulses is reversed for negative delays:

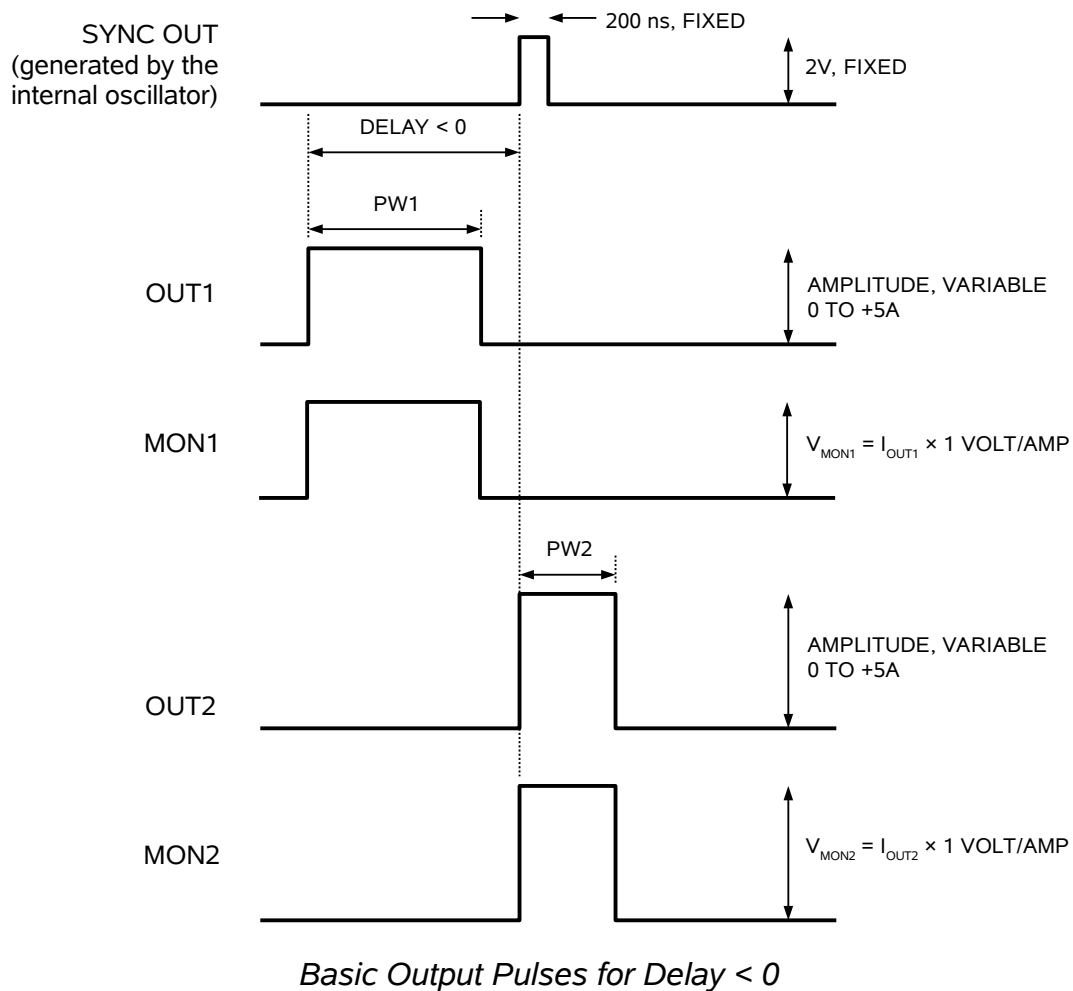

The delay, pulse width, and frequency (when in the internal mode), of the OUT pulse can be varied with front panel controls or via the GPIB or RS-232 computer interfaces.

### MONITOR CIRCUIT

As noted in the previous section, current monitor outputs are available. The current monitor output also measures amplitude of the most recent pulse, in amperes, and displays it on the front panel LCD.

### TRIGGER MODES

This instrument has four front-panel trigger modes:

- Internal Trigger: the instrument controls the trigger frequency, and generates the clock internally.

- External Trigger: the instrument is triggered by an external TTL-level clock on the back-panel TRIG connector.
- Manual Trigger: the instrument is triggered by the front-panel “SINGLE PULSE” pushbutton.
- Hold Trigger: the instrument is set to not trigger at all.

These modes can be selected using the front panel trigger menu, or by using the appropriate programming commands. (See the “Programming Manual for -B Instruments” for more details.)

When being controlled by a computer, there is a fifth trigger mode:

- Immediate Trigger: generates a single trigger event. This is the computer-control equivalent of pressing the front-panel “SINGLE PULSE” pushbutton.

### GATING MODES

Triggering can be suppressed by a TTL-level signal on the rear-panel GATE connector. The instrument can be set to stop triggering when this input high or low, using the front-panel gate menu or the appropriate programming commands.

This gate signal acts synchronously - i.e., when gated, the output will complete the full pulse width if the output is high, and then stop triggering. No pulses are truncated in this mode.

### AVOID EXCESS POWER DISSIPATION

To prolong the life of the output stages of the instrument, the internal power dissipation should be minimized whenever practical. The power dissipated in each of the two output stages can be calculated using:

$$P_{DISS} = (36 \text{ Volts} - V_{LOAD}) \times I_{PEAK} \times \text{Duty Cycle}$$

To minimize power dissipation, keep the current amplitude and duty cycle as low as practical. Operation into larger load resistance is preferred over operation into a low load resistance, since  $V_{LOAD} = I_{PEAK} \times R_{LOAD}$ .

## LOAD PROTECTION

### LENZ'S LAW AND INDUCTIVE VOLTAGE SPIKES

This instrument is designed to pulse resistive and diode loads and will exhibit a large output spike when used to drive a load with significant inductance (as predicted by LENZ'S LAW). For this reason the load should be connected to the output using low inductance leads (as short as possible and as heavy a gauge as possible).

The voltage developed across an inductance  $L$  (in Henries), when the current is changing at a rate given by  $di_{LOAD}/dt$  (in Amps/sec), is:  $V_{SPIKE} = L \times di_{LOAD}/dt$ .

### OSCILLATIONS ON THE OUTPUT

If oscillations are observed on the output, it is probably because the load is too inductive for the instrument to operate properly. This can normally be corrected by adding a small resistance (i.e., 0.5 or 1.0 Ohms) in series with the load.

### OUTPUT ON/OFF

The main outputs may be switched on and off using the front-panel controls or via programming commands. When the output is set "OFF", the main outputs are short-circuited to ground with a relay, and the trigger source is removed from the output stage.

### ATTACHING AND DETACHING LOADS

To avoid damaging the loads connected to main outputs, the loads should only be connected to or removed from the instrument when:

- the instrument is off
- the instrument is on, but the outputs are turned off (i.e. the LCD display reads "OUTPUT OFF")

Do not connect loads when the instrument is on and the outputs are turned on. This can cause mild sparking.

### CHANGING PARAMETERS WHEN A LOAD IS ATTACHED

If your load is easily damaged, the outputs should be turned off when changing the trigger source, frequency, pulse width, or other pulse parameters. This protects the loads from possible short transient effects.

## OPEN AND SHORT CIRCUITS

The AV-156E-B will operate properly into a short circuit to ground. (However, if the “short circuit” has significant parasitic inductance, some oscillations may be observed. Please see the “Oscillations on the Output” section above for details.)

Operation into an open circuit will not damage the instrument in any way, although the monitor circuit may not give the correct reading (which should be zero).

## OPERATIONAL CHECK

This section describes a sequence to confirm the basic operation of the instrument. It should be performed after receiving the instrument. It is a useful learning exercise as well.

Before proceeding with this procedure, finish reading this instruction manual thoroughly. Then read the “Local Control” section of the “Programming Manual for -B Instruments” thoroughly. The “Local Control” section describes the front panel controls used in this operational check - in particular, the MOVE, CHANGE, and ADJUST controls.

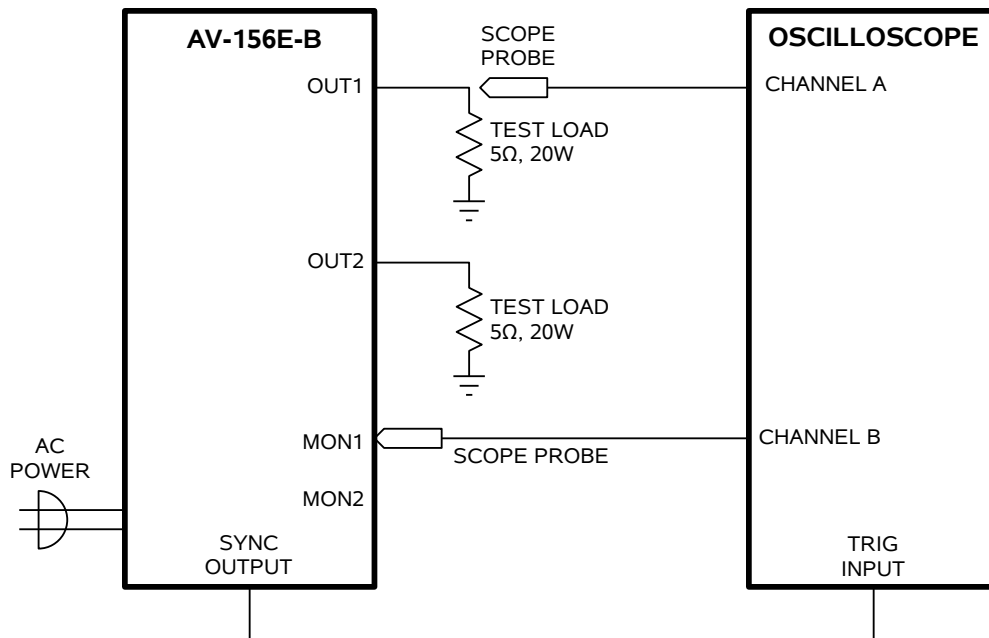

*Basic Test Arrangement*

1. Connect a 20W, 5Ω test load between the OUT1 connector and ground.
2. Connect a 20W, 5Ω test load between the OUT2 connector and ground.
3. Connect a cable from the SYNC OUT connector to the TRIG input of an oscilloscope. Set the oscilloscope to trigger externally.
4. Connect one oscilloscope probe (channel A) to the OUT1 load. Connect the other probe to the MON1 output (on the rear panel). On the oscilloscope, set the channel A vertical scale to 10 V/div, the channel B vertical scale to 2 V/div, and the horizontal scale to 1 ms/div.
5. Turn on the AV-156E-B. The instrument will execute a warm-up sequence for 45 seconds, during which time the internal capacitor banks are charged. Wait for this sequence to complete. After this delay, the main menu will appear on the LCD.



6. To set the AV-156E-B to trigger from the internal clock at a PRF of 30 Hz:
  - a) The arrow pointer should be pointing at the frequency menu item. If it is not, press the MOVE button until it is.
  - b) Press the CHANGE button. The frequency submenu will appear. Rotate the ADJUST knob until the frequency is set at 30 Hz.
  - c) The arrow pointer should be pointing at the “Internal” choice. If it is not, press MOVE until it is.
  - d) Press CHANGE to return to the main menu.
7. To set the delay to 2 ms:
  - a) Press the MOVE button until the arrow pointer is pointing at the delay menu item.
  - b) Press the CHANGE button. The delay submenu will appear. Rotate the ADJUST knob until the delay is set at 2 ms.
  - c) Press CHANGE to return to the main menu.
8. To set the OUT1 pulse width to 1.5 ms:
  - a) Press the MOVE button until the arrow pointer is pointing at the “PW1” menu item.
  - b) Press the CHANGE button. The pulse width submenu will appear. Rotate the ADJUST knob until the pulse width is set at 1.5 ms.
  - c) The arrow pointer should be pointing at the “Normal” choice. If it is not, press MOVE until it is.
  - d) Press CHANGE to return to the main menu.
9. To set the OUT2 pulse width to 2 ms:
  - a) Press the MOVE button until the arrow pointer is pointing at the “PW2” menu item.
  - b) Press the CHANGE button. The pulse width submenu will appear. Rotate the ADJUST knob until the pulse width is set at 2 ms.
  - c) The arrow pointer should be pointing at the “Normal” choice. If it is not, press MOVE until it is.
  - d) Press CHANGE to return to the main menu.
10. At this point, nothing should appear on the oscilloscope.

11. To enable the output:

- a) Press the MOVE button until the arrow pointer is pointing at the output menu item.
- b) Press the CHANGE button. The output submenu will appear.
- c) Press MOVE until the arrow pointer is pointing at the "ON" choice.
- d) Press CHANGE to return to the main menu.

12. To change the OUT1 output amplitude:

- a) Press the MOVE button until the arrow pointer is pointing at the AMP1 menu item.
- b) Press the CHANGE button. The amplitude submenu will appear. Rotate the ADJUST knob until the amplitude is set at 5A.
- c) Observe the oscilloscope. You should see 1.5 ms wide, 25V pulses (i.e.,  $5A \times 5\Omega = 25V$ ) on the probe connected to the OUT1 main output. The other probe, connected to the MON1 monitor output, should show 1.5ms, 5V pulses (i.e.  $5A \times 1V/A$ ).
- d) Press CHANGE to return to the main menu.

13. Try varying the pulse width, by repeating step (8). As you rotate the ADJUST knob, the pulse width on the oscilloscope will change. It should agree with the displayed value. Stay below 10% duty cycle.

14. Move the oscilloscope probes from OUT1 and MON1 to OUT2 and MON2, respectively, and repeat steps 12 and 13 using the AMP2 and PW2 menus to change the second channel output.

15. This completes the operational check.

## CALIBRATION

### TIMING CALIBRATION

The frequency, pulse width and delay of this instrument can be re-calibrated automatically (using an internal crystal timing reference) or manually (using external measurement systems).

The instrument contains a timebase self-calibration circuit. This will run an automatic timing self-calibration on every 5<sup>th</sup> power-up. It can also be triggered manually by running the new "cal?" command, or by selecting the "Setup menu > Self Cal" menu item. This self-calibration will take 6-12 minutes typically.

The self-calibration interval can be adjusted using the "cal:freq" command. To disable automatic self-calibration on power-up, send "cal:freq 0". To force a self-calibration on every power-up, send "cal:freq 1". To force a self-calibration on every 8<sup>th</sup> power-up, send "cal:freq 8". To check the current setting, send "cal:freq?".

A self-calibration should always be performed after the instrument has been moved or shipped.

Manual timebase calibration is discussed in detail in Avtech Technical Brief 4, "How Can I Calibrate the Timebase of my Avtech Pulse Generator?", on the web at <http://www.avtechpulse.com/appnote/techbrief4>.

### AMPLITUDE CALIBRATION

The amplitude can be re-calibrated manually, if required.

Amplitude calibration is discussed in detail in Avtech Technical Brief 5, "How Can I Calibrate the Amplitude and Offset of my Avtech Pulse Generator?", on the web at <http://www.avtechpulse.com/appnote/techbrief5>.

### CURRENT MONITOR CALIBRATION

If it is found that the current monitor readings (as displayed on the front-panel) do not agree exact with measured values of amplitude (i.e., by examining the output on an oscilloscope), the monitor calibration can be updated using software commands.

The following procedure is suggested:

- 1) Connect a precision resistive load to the output. (As an example, suppose 4.0Ω is used.)

- 2) Connect the pulse generator to a computer using the GPIB or RS232 ports.
- 3) Turn on the pulse generator, and set the time controls (frequency, delay, pulse width) to typical values.
- 4) Turn on the outputs.
- 5) Set the output amplitude to 240 mA.
- 6) Observe the voltage across the load. (Continuing the 4.0 $\Omega$  example, suppose that 1.00V is observed.) From this, calculate the measured current (250 mA).
- 7) Send one of the following commands to the instrument via the computer interface:

diag:mon:cal1 0.250A      (if channel 1 is being checked)  
diag:mon:cal2 0.250A      (if channel 2 is being checked)

The internal software compares the supplied measured value to the monitor reading, and adjusts the internal calibration data to null out any differences.

- 8) Observe the voltage across the load again. The monitor reading should now agree with the measured value.
- 9) Set the output amplitude to 5.0 A.
- 10) Observe the voltage across the load. (Continuing the 4.0 $\Omega$  example, suppose that 21V is observed.) From this, calculate the measured current (5.25 A).
- 11) Send one of the following commands to the instrument via the computer interface:

diag:mon:cal1 5.25A      (if channel 1 is being checked)  
diag:mon:cal2 5.25A      (if channel 2 is being checked)

The internal software compares the supplied measured value to the monitor reading, and adjusts the internal calibration data to null out any differences.

- 12) Observe the voltage across the load again. The monitor reading should now agree with the measured value.

The current monitor should be calibrated at 240 mA and 5 A, for channels 1 and 2.

Note that this procedure affects the current monitor readings shown on the front-panel display (or read using the "measure:amplitude?" commands) only. It does not change the waveforms present on the rear-panel monitor connectors.

## PROGRAMMING YOUR PULSE GENERATOR

### KEY PROGRAMMING COMMANDS

The “Programming Manual for -B Instruments” describes in detail how to connect the pulse generator to your computer, and the programming commands themselves. A large number of commands are available; however, normally you will only need a few of these. Here is a basic sample sequence of commands that might be sent to the instrument after power-up, using the internal trigger source:

*rst	(resets the instrument)
trigger:source internal	(selects internal triggering)
frequency 10 Hz	(sets the frequency to 10 Hz)
pulse:width1 1 ms	(sets the channel 1 pulse width to 1 ms)
pulse:width2 3 ms	(sets the channel 1 pulse width to 3 ms)
pulse:delay 10 ms	(sets the inter-channel delay to 10 ms)
output on	(turns on the output for both channels)
source:current1 500 mA	(sets the channel 1 current amplitude to 0.5 amperes)
source:current2 5 A	(sets the channel 2 current amplitude to 5 amperes)
measure:amplitude1?	(this returns the current amplitude, in amperes, as measured by the monitor circuit on channel 1)
measure:amplitude2?	(this returns the current amplitude, in amperes, as measured by the monitor circuit on channel 2)

For triggering a single event, this sequence would be more appropriate:

*rst	(resets the instrument)
trigger:source hold	(turns off all triggering)
pulse:width1 1 ms	(sets the channel 1 pulse width to 1 ms)
pulse:width2 3 ms	(sets the channel 1 pulse width to 3 ms)
pulse:delay 10 ms	(sets the inter-channel delay to 10 ms)
output on	(turns on the output for both channels)
source:current1 500 mA	(sets the channel 1 current amplitude to 0.5 amperes)
source:current2 5 A	(sets the channel 2 current amplitude to 5 amperes)
trigger:source immediate	(generates a single non-repetitive trigger event)
trigger:source hold	(turns off all triggering)
output off	(turns off both outputs)

These commands will satisfy 90% of your programming needs.

### ALL PROGRAMMING COMMANDS

For more advanced programmers, a complete list of the available commands is given below. These commands are described in detail in the “Programming Manual for -B Instruments”. (Note: this manual also includes some commands that are not implemented in this instrument. They can be ignored.)

Note that the pulse width, amplitude, and monitor-related commands should be suffixed with the channel number, as illustrated in the previous section. If the suffix is not included, channel 1 will be assumed. The remaining commands will generate an error if a channel suffix is attached, since their effects are common to both channels.

<u>Keyword</u>	<u>Parameter</u>	<u>Notes</u>
CALibration:		
:[ALL]		
:FREQuency		
MEASure:		
:AMPLitude?		[query only]
OUTPut:		
:[STATe]	<boolean value>	
:PROTection		
:TRIPped?		[query only]
[SOURce]:		
:FREQuency		
[:CW   FIXed]	<numeric value>	
[SOURce]:		
:CURRent		
[:LEVel]		
[:IMMediate]		
[:AMPLitude]	<numeric value>   EXTernal	
:PROTection		
:TRIPped?		[query only]
[SOURce]:		
:PULSe		
:PERiod	<numeric value>	
:WIDTh	<numeric value>	
:DCYCLE	<numeric value>	
:HOLD	WIDTh   DCYCLE	
:DELay	<numeric value>	
:GATE		
:LEVel	High   Low	
STATUS:		
:OPERation		
:[EVENT]?		[query only, always returns "0"]
:CONDition?		[query only, always returns "0"]
:ENABle	<numeric value>	[implemented but not useful]
:QUEStionable		
:[EVENT]?		[query only, always returns "0"]
:CONDition?		[query only, always returns "0"]
:ENABle	<numeric value>	[implemented but not useful]
SYSTem:		
:COMMunicate		
:GPIB		
:ADDRess	<numeric value>	
:SERial		
:CONTRol		
:RTS	ON   IBFull   RFR	
:[RECeive]		
:BAUD	1200   2400   4800   9600   19200   38400   57600   115200	
:ERRor		
:[NEXT]?		[query only]
:COUNT?		[query only]
:VERSion?		[query only]

TRIGger:	INTernal   EXTernal   MANual   HOLD   IMMEDIATE	
:SOURce		[no query form]
*CLS	<numeric value>	
*ESE		[query only]
*ESR?		[query only]
*IDN?		
*OPC		
*SAV	0   1   2   3	[no query form]
*RCL	0   1   2   3	[no query form]
*RST		[no query form]
*SRE	<numeric value>	
*STB?		[query only]
*TST?		[query only]
*WAI		[no query form]

## MECHANICAL INFORMATION

### TOP COVER REMOVAL

If necessary, the interior of the instrument may be accessed by removing the four Phillips screws on the top panel. With the four screws removed, the top cover may be slid back (and off).

There are no user-adjustable internal circuits. For repairs other than fuse replacement, please contact Avtech (info@avtechpulse.com) to arrange for the instrument to be returned to the factory for repair. Service is to be performed solely by qualified service personnel.

 Caution: High voltages are present inside the instrument during normal operation. Do not operate the instrument with the cover removed.

 Caution: Significant stored charge is present in the instrument. Before removing the top cover, unplug the instrument and allow it to sit unpowered for 30 minutes. Do not service the instrument if any internal LEDs (indicators) are still lit.

### RACK MOUNTING

A rack mounting kit is available. The -R5 rack mount kit may be installed after first removing the one Phillips screw on the side panel adjacent to the front handle.

### ELECTROMAGNETIC INTERFERENCE

To prevent electromagnetic interference with other equipment, all used outputs should be connected to shielded loads using shielded coaxial cables. Unused outputs should be terminated with shielded coaxial terminators or with shielded coaxial dust caps, to prevent unintentional electromagnetic radiation. All cords and cables should be less than 3m in length.



## MAINTENANCE

### REGULAR MAINTENANCE

This instrument does not require any regular maintenance.

On occasion, one or more of the four rear-panel fuses may require replacement. All fuses can be accessed from the rear panel. See the “FUSES” section for details.

### CLEANING

If desired, the interior of the instrument may be cleaned using compressed air to dislodge any accumulated dust. (See the “TOP COVER REMOVAL” section for instructions on accessing the interior.) No other cleaning is recommended.

### TRIGGER DAMAGE

The rear-panel TRIG input, used in the external trigger mode, is protected by a diode clamping circuit. However, the protection circuit is not foolproof, and it is possible for a grossly excessive signal to damage the trigger circuitry on the main timing control board (the 4×10 inch board on the right side of the instrument).

The IC that is most likely to fail under these conditions is installed in a socket. It is a standard TTL IC in a 16-pin plastic DIP package, model 74F151 or equivalent.

If you suspect that this IC has been damaged, turn off the power and replace this IC. It may be replaced by a 74F151, 74LS151, 74ALS151, or 74HCT151.

# WIRING DIAGRAMS

## WIRING OF AC POWER

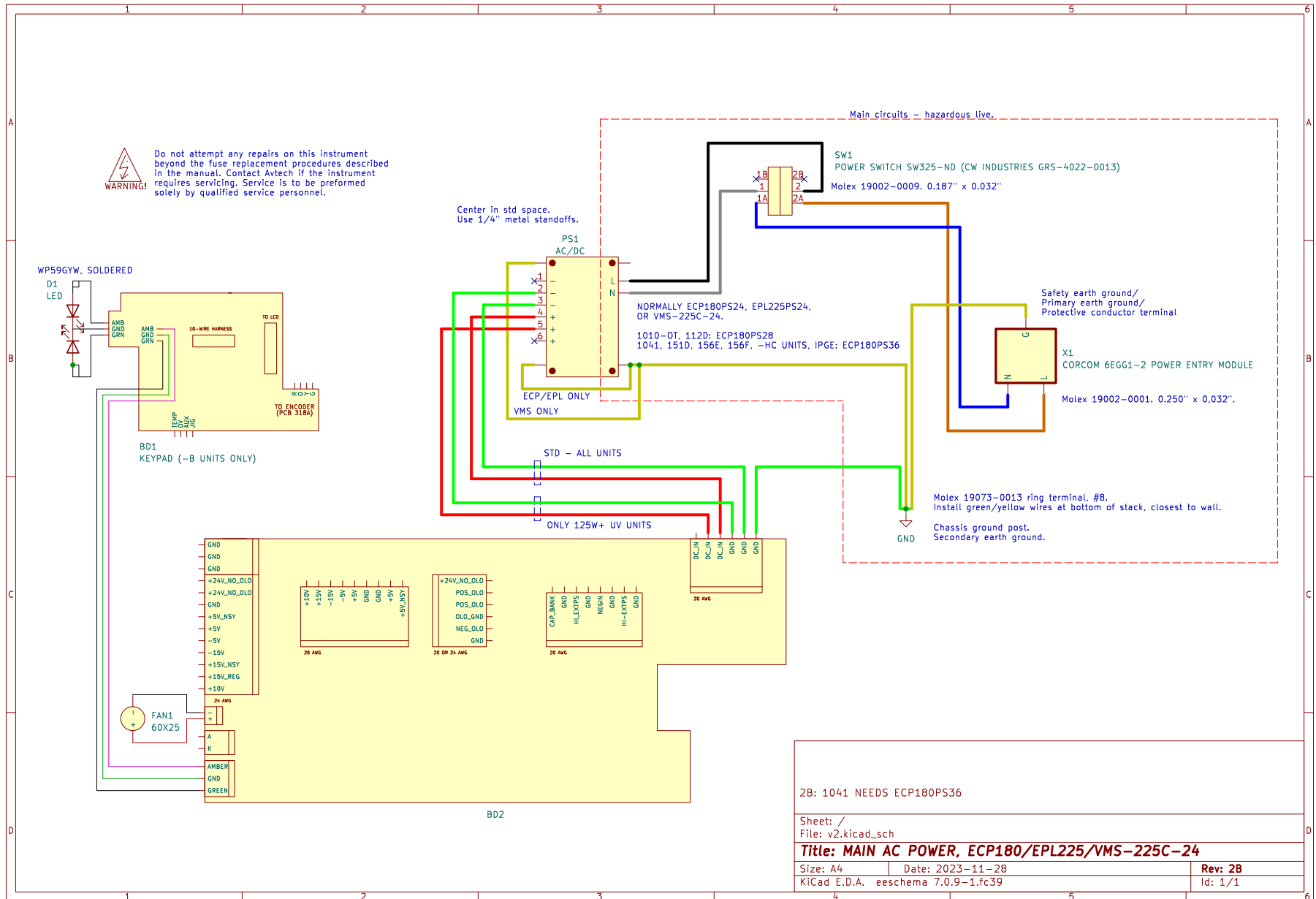

# WIRING OF DC POWER

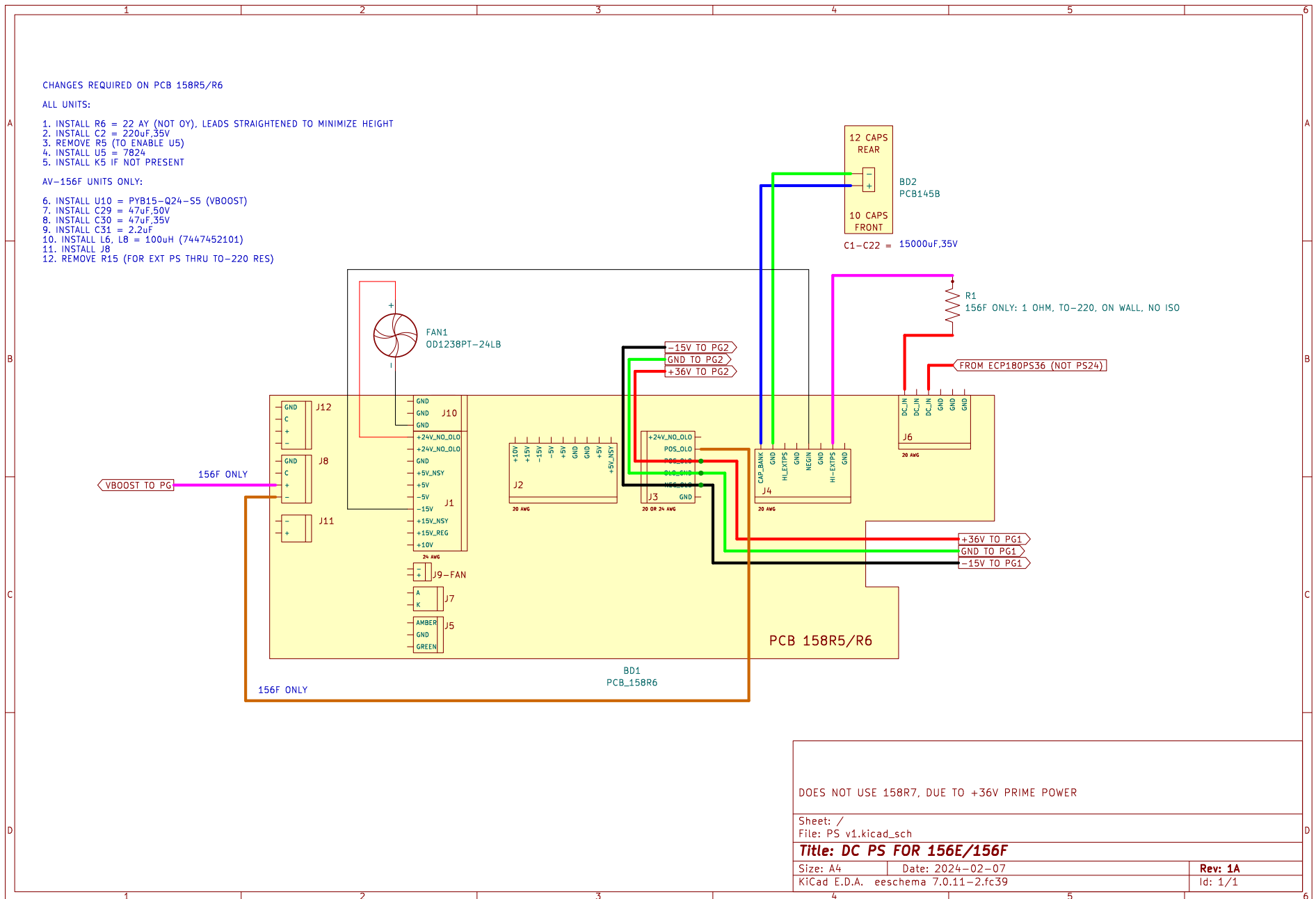

# PCB 158R4 - LOW VOLTAGE POWER SUPPLY

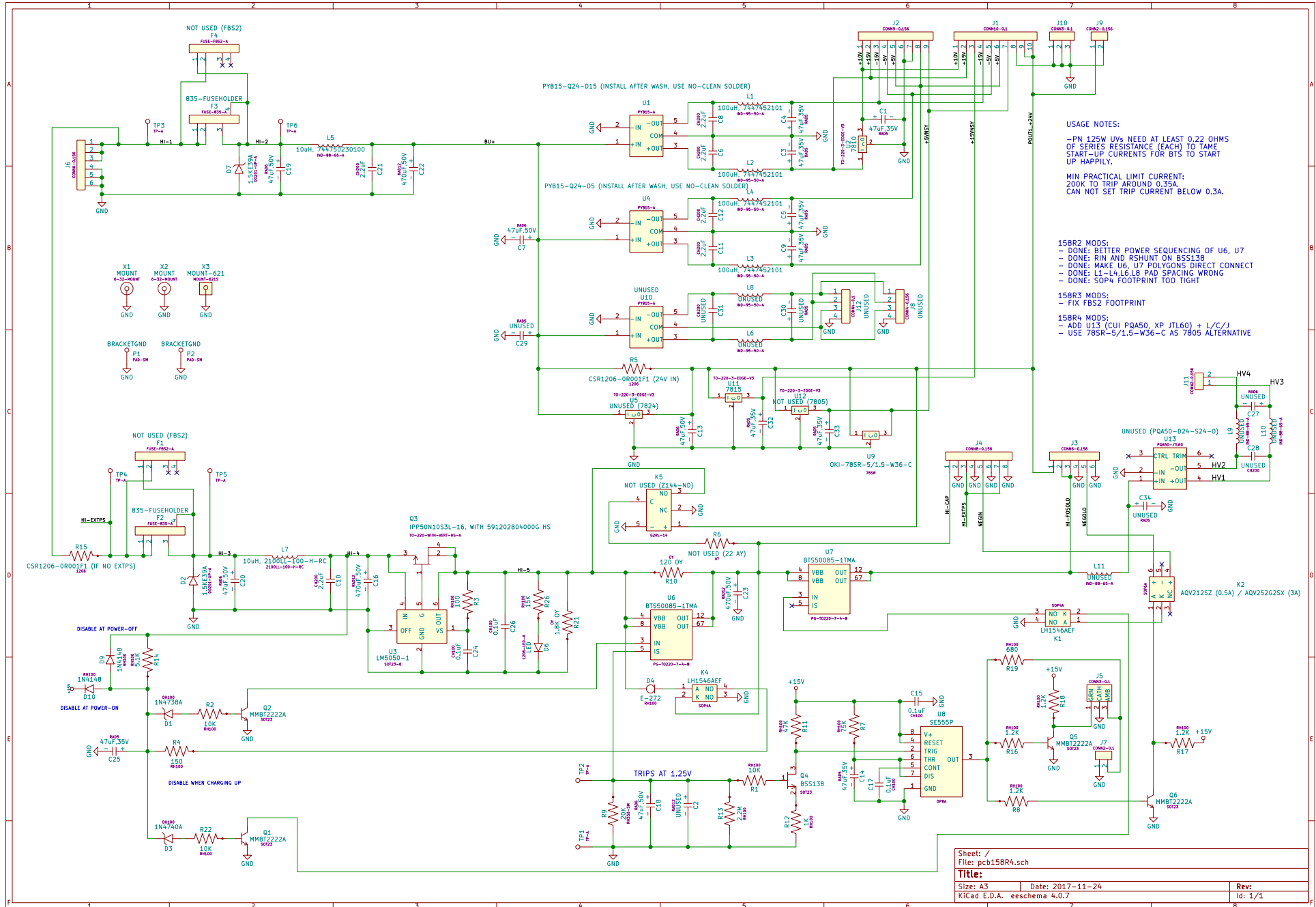

# PCB 174B - DUAL PW PCB

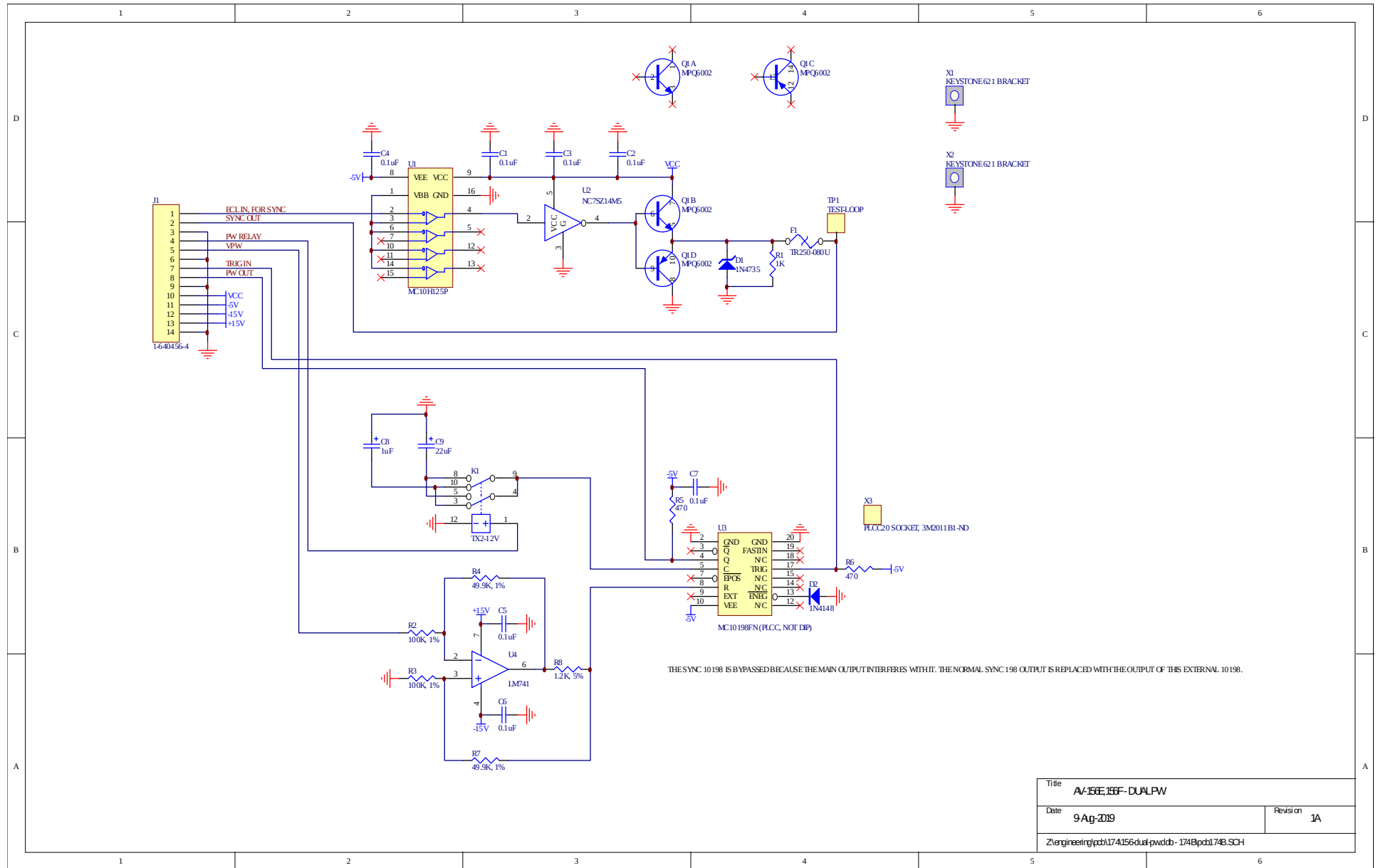

Title		A-156E,15F- DUALPW
Date	9 Aug 2019	Revision 1A
Z:\engineering\pcb\174156\dual\pwddb-174B\pcb174B.SCH		

# PCB 116D - CURRENT MONITOR BOARD

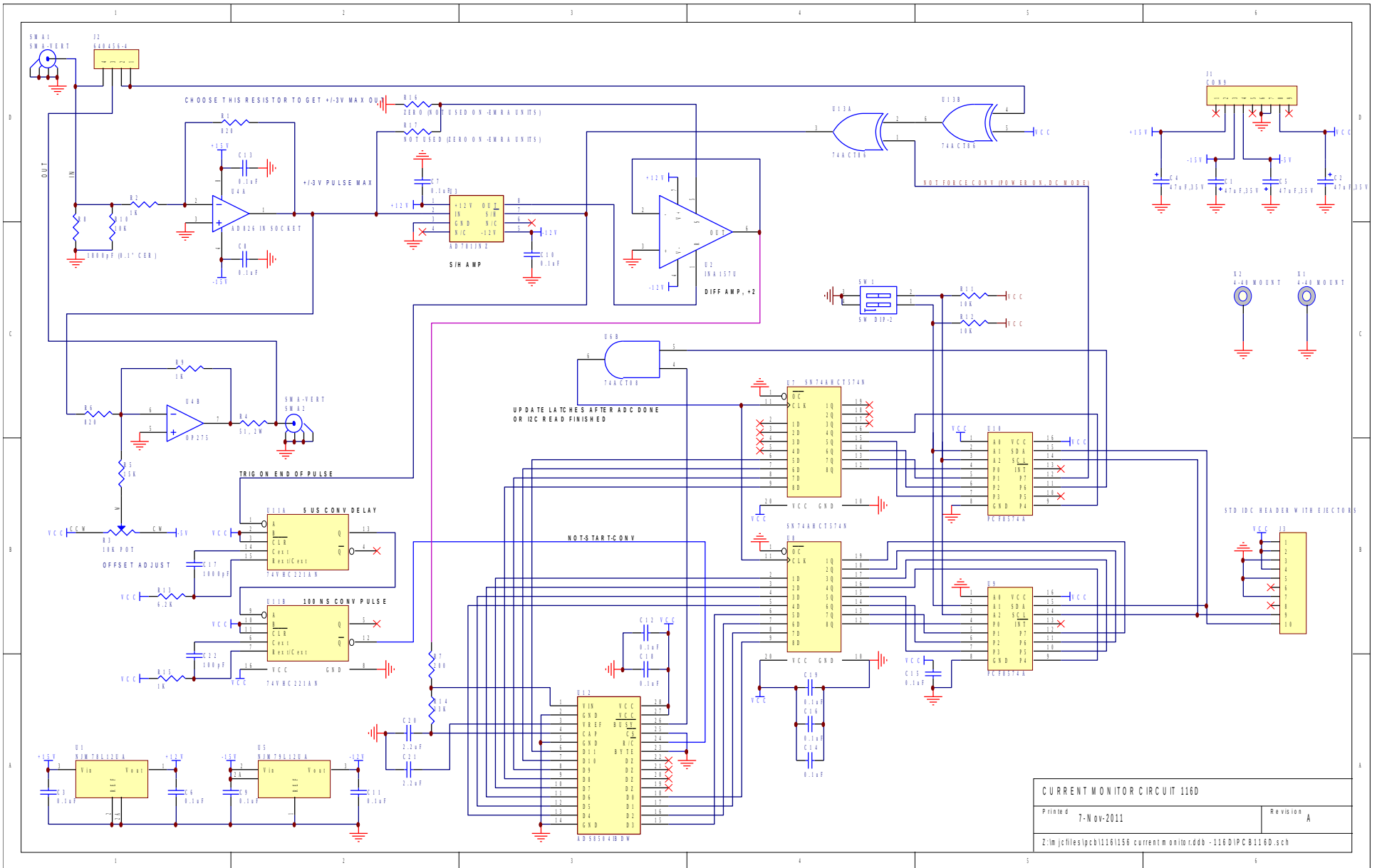

# PCB 226B - SELF-CALIBRATION

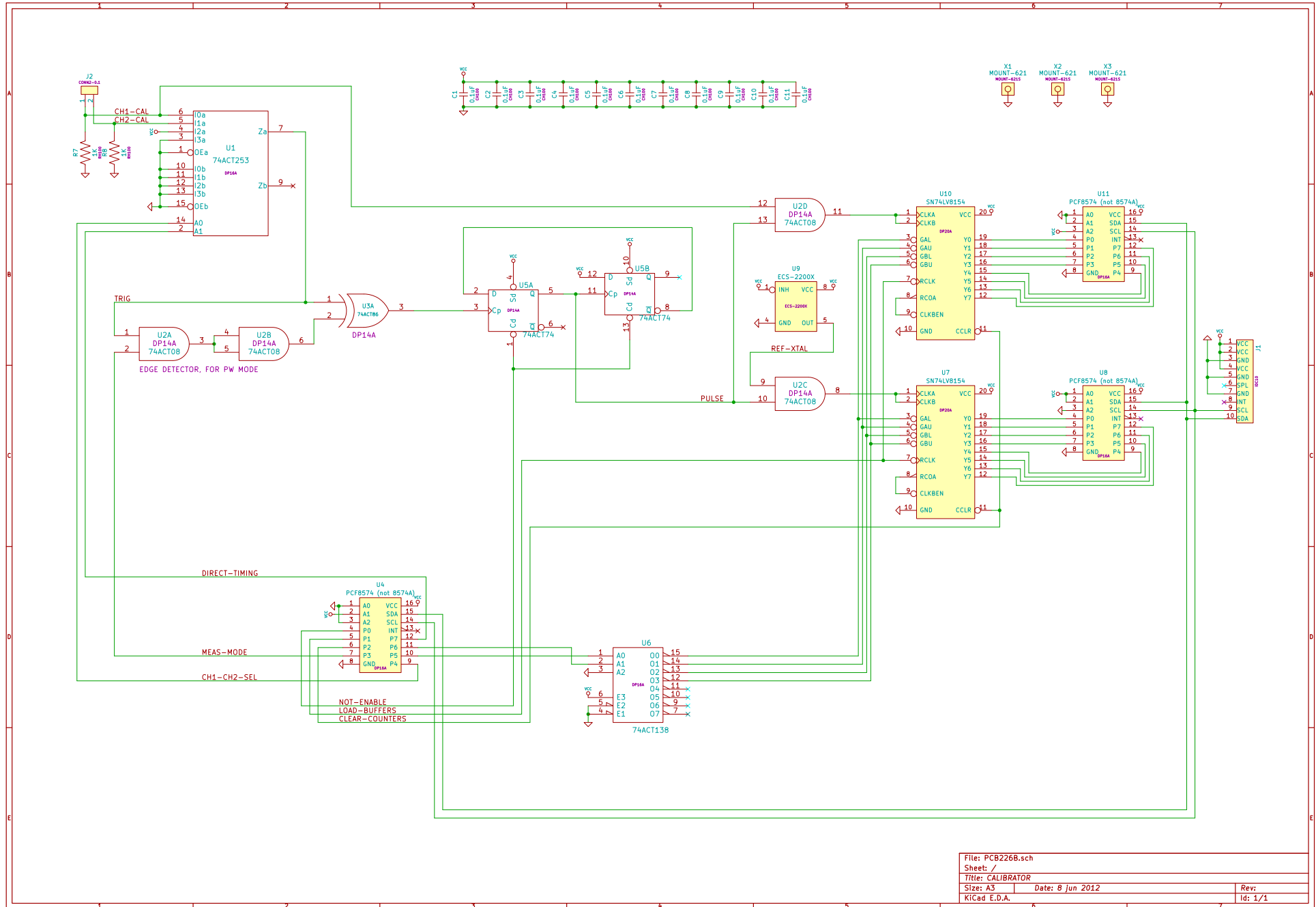

# PCB 104H - KEYPAD / DISPLAY BOARD

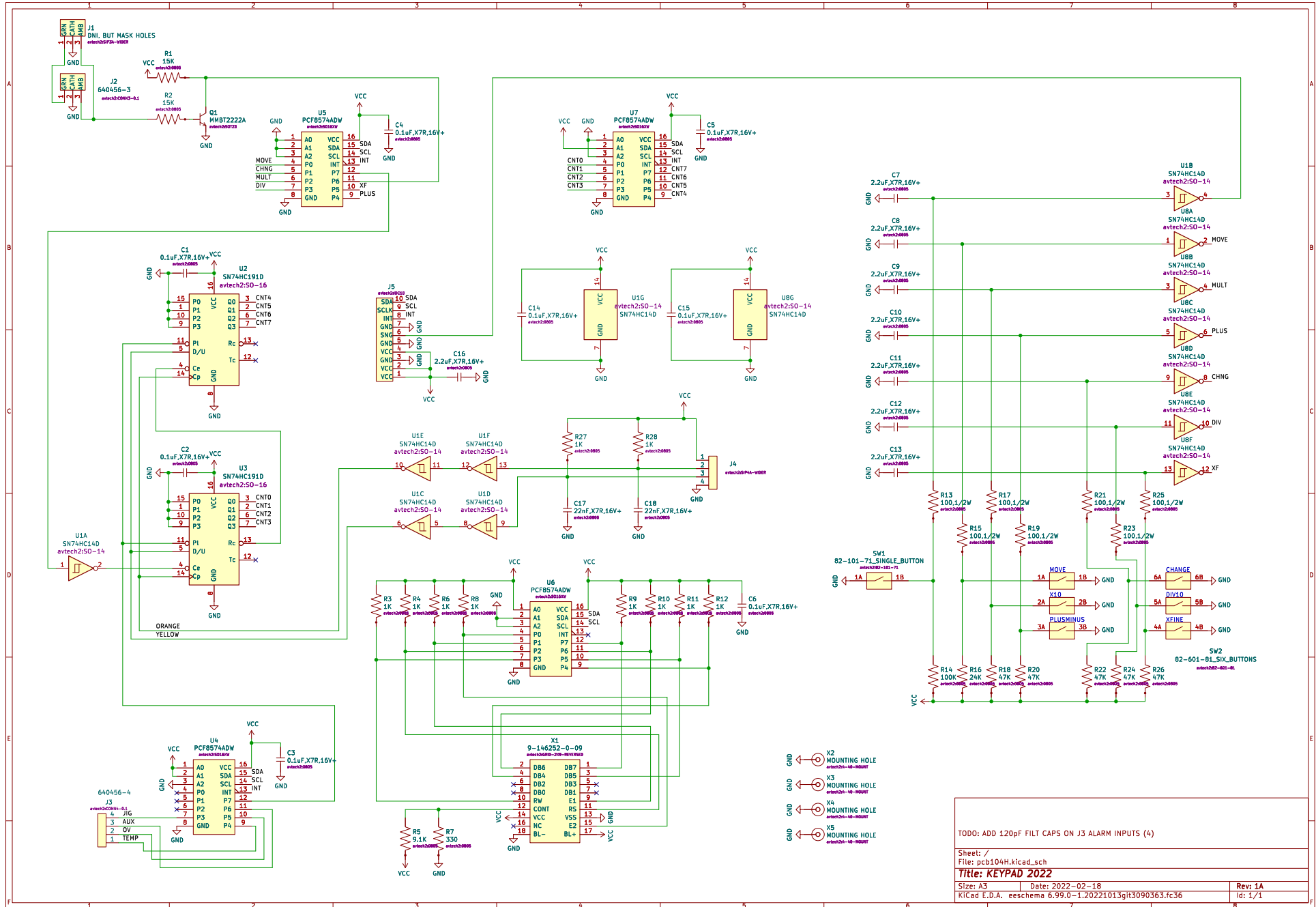





PERFORMANCE CHECK SHEET