



AVTECH ELECTROSYSTEMS LTD.

NANOSECOND WAVEFORM ELECTRONICS
SINCE 1975

info@avtechpulse.com
<http://www.avtechpulse.com/>

Tel: 888-670-8729 (USA & Canada)
or +1-613-686-6675 (Worldwide)

BOX 5120, LCD MERIVALE
OTTAWA, CANADA K2C3H5

INSTRUCTIONS

MODEL AVOZ-A3-B

100 VOLT / 100 AMP, PULSED VOLTAGE

LASER DIODE DRIVER

WITH IEEE 488.2 AND RS-232 CONTROL

SERIAL NUMBER: 14307

WARRANTY

Avtech Electrosystems Ltd. warrants products of its manufacture to be free from defects in material and workmanship under conditions of normal use. If, within one year after delivery to the original owner, and after prepaid return by the original owner, this Avtech product is found to be defective, Avtech shall at its option repair or replace said defective item. This warranty does not apply to units which have been disassembled, modified or subjected to conditions exceeding the applicable specifications or ratings. This warranty is the extent of the obligation assumed by Avtech with respect to this product and no other warranty or guarantee is either expressed or implied.

TECHNICAL SUPPORT

Phone: 888-670-8729 (USA & Canada)
or +1-613-686-6675 (Worldwide)

E-mail: info@avtechpulse.com
World Wide Web: <http://www.avtechpulse.com>

TABLE OF CONTENTS

WARRANTY.....2

TECHNICAL SUPPORT.....2

TABLE OF CONTENTS.....3

INTRODUCTION.....5

SPECIFICATIONS.....6

REGULATORY NOTES.....8

 FCC PART 18.....8

 EC DECLARATION OF CONFORMITY.....8

 DIRECTIVE 2011/65/EU (RoHS).....9

 DIRECTIVE 2002/96/EC (WEEE).....9

 FIRMWARE LICENSING.....10

INSTALLATION.....11

 VISUAL CHECK.....11

 POWER RATINGS.....11

 CONNECTION TO THE POWER SUPPLY.....11

 PROTECTION FROM ELECTRIC SHOCK.....12

 ENVIRONMENTAL CONDITIONS.....13

 LABVIEW DRIVERS.....13

FUSES.....14

 AC FUSE REPLACEMENT.....14

 DC FUSE REPLACEMENT.....15

 FUSE RATINGS.....15

FRONT PANEL CONTROLS.....16

REAR PANEL CONTROLS.....18

GENERAL INFORMATION - PULSE GENERATOR TIMING.....20

 BASIC PULSE CONTROL.....20

 TRIGGER MODES.....21

 GATING MODES.....21

GENERAL INFORMATION - OPERATING INTO A LOAD.....23

 AMPLITUDE CONTROL.....23

 SELECTING THE SERIES RESISTANCE.....23

 OUTPUT CONNECTIONS.....23

 USING THE SUPPLIED TEST LOAD (AV-CTL1-ENC).....24

TEST ARRANGEMENT.....	25
LENZ'S LAW AND INDUCTIVE VOLTAGE SPIKES.....	27
ATTACHING AND DETACHING LOADS.....	27
MEASURING OUTPUT CURRENT.....	27
START-UP CHECK-LIST FOR LOCAL CONTROL.....	29
CALIBRATION ADJUSTMENTS - SOFTWARE PROCEDURES.....	31
ADJUSTING AMPLITUDE ACCURACY.....	31
PROGRAMMING YOUR PULSE GENERATOR.....	32
KEY PROGRAMMING COMMANDS.....	32
ALL PROGRAMMING COMMANDS.....	33
MECHANICAL INFORMATION.....	35
TOP COVER REMOVAL.....	35
RACK MOUNTING.....	35
ELECTROMAGNETIC INTERFERENCE.....	35
MAINTENANCE.....	36
REGULAR MAINTENANCE.....	36
CLEANING.....	36
TRIGGER DAMAGE.....	36
WIRING DIAGRAMS.....	37
WIRING OF AC POWER.....	37
PCB 158R7 - LOW VOLTAGE POWER SUPPLY.....	38
PCB 284C - HIGH VOLTAGE DC POWER SUPPLY.....	39
PCB 156D - POLARITY CONTROL PCB (-PN UNITS).....	40
PCB 104H - KEYPAD / DISPLAY BOARD.....	41
MAIN WIRING.....	42
PERFORMANCE CHECK SHEET.....	43

INTRODUCTION

The Model AVOZ-A3-B pulse generator is designed for pulsing laser diode and other low impedance loads with rectangular pulses as high as 100V into $1\ \Omega$ (i.e. 100 Amps) with $< 35\ \text{ns}$ rise times. The current and voltage polarities depend on the model number:

- P units: up to +100 V amplitude (0 to +100 Amps)
- N units: up to -100 V amplitude (0 to -100 Amps)
- PN units: up to $\pm 100\ \text{V}$ amplitude (0 to $\pm 100\ \text{Amps}$)

The pulse repetition frequency can vary from 1 Hz to 20 kHz, and pulse widths can vary from 50 ns to 2 μs . The maximum duty cycle is 0.1%, and the maximum average output power is 10 Watts.

The Model AVOZ-A3-B pulse generator is a voltage pulser. The current amplitude is determined by Ohm's Law. That is, the current is the output voltage divided by the load resistance. The load resistance should be approximately $1\ \Omega$ to attain a peak current of 100 A.

The loads can be connected to the pulse generator using the convenient AV-CLZ1-60 transmission line cable assembly, which has a $1\ \Omega$ characteristic impedance (Z_0), and is terminated with a DB-37 male connector. A sample connectorized test load is provided.

The AVOZ-A3-B can be controlled from the front panel, or via a computer connected to the IEEE 488.2-compliant GPIB port, or the RS-232 serial port.

This instrument is intended for use in research, development, test and calibration laboratories by qualified personnel.

SPECIFICATIONS

Model ¹ :	AVOZ-A3-B
Amplitude, voltage ^{2,3,11} :	< 5V to 100V
Maximum current:	100A
Minimum load impedance ⁴ :	1 Ω
Pulse width (FWHM):	50 ns – 2 μ s
Rise, fall times (20%-80%) ⁹ :	\leq 35 ns
Maximum PRF:	20 kHz
Duty cycle: (max)	0.1%
Output impedance:	\leq 0.05 Ω
Average output power:	10 W max.
Droop:	\leq 5%, at maximum pulse width and maximum amplitude
Polarity ⁵ :	Positive or negative or dual polarity (specify)
GPIO & RS-232 control ¹ :	Standard on -B units.
LabView drivers:	Check http://www.avtechpulse.com/labview for availability and downloads
Ethernet port, for remote control using VXI-11.3, ssh, telnet, & web:	Included. Recommended as a modern alternative to GPIO / RS-232. See http://www.avtechpulse.com/options/vxi for details.
Settings resolution:	The resolution of the timing parameters (pulse width, delay, period) varies, but is always better than 0.15% of (set value + 20 ns). The amplitude resolution is < 0.1% of the maximum amplitude.
Settings accuracy:	Typically \pm 3% (plus \pm 1V or \pm 2 ns) after 10 minute warmup, at low duty cycles ¹² . For high-accuracy applications requiring traceable calibration, verify the output parameters with a calibrated oscilloscope ¹³ .
Propagation delay:	\leq 100 ns (Ext trig in to pulse out)
Jitter:	$\leq \pm$ 35ps \pm 0.015% RMS (sync out to pulse out)
Trigger modes:	Internal trigger, external trigger (TTL-level pulse, > 10 ns, 1 k Ω input impedance), front-panel "Single Pulse" pushbutton, or single pulse trigger via computer command.
Variable delay:	Sync to main out: 0 to 1.0 seconds, for all trigger modes (including external trigger).
Sync output:	> +3 Volts, > 50 ns, will drive 50 Ohm loads
Gate input:	Synchronous or asynchronous, active high or low, switchable. Suppresses triggering when active.
Included output cable:	Detachable high-current transmission line cable assembly.
Part number: length, Z ₀ :	AV-CLZ1-60 (see http://www.avtechpulse.com/transmission/av-clz1) 1 Ω , 60 cm
Output connection:	End of cable: DB-37 male. Pins 1-19 = signal, pins 20-37 = ground.
Supplied test load ⁶ :	AV-CTL1-ENC
Other signal connectors:	Trig, Gate, Sync: BNC
Power required:	100 - 240 Volts, 50 - 60 Hz
Dimensions (H x W x D):	100 x 430 x 375 mm (3.9" x 17" x 14.8")
Chassis material:	Anodized aluminum, with blue plastic trim
Optional rack-mount kit:	Add -R5 suffix.
Temperature range:	+5°C to +40°C

- 1) -B suffix indicates IEEE-488.2 GPIO and RS-232 control of pulse amplitude, pulse width, delay and PRF. (See <http://www.avtechpulse.com/gpio>).
- 2) For remote analog electronic control (0 to + 10V) of the amplitude, suffix model number with -EA. Electronic control units also include standard front-panel controls. Not available for the AVOZ-B4-B.
- 3) For operation at voltage amplitudes of less than 10% of the full-scale voltage, better results may be obtained by setting the amplitude near full-scale and increasing the load impedance accordingly.
- 4) Required to limit output current. For applications where additional resistance must be added in series with the device under test, Avtech recommends connecting multiple Ohmite OY-series (<http://www.ohmite.com>) ceramic composition resistors in parallel to create a high-power, low-inductance effective resistance.
- 5) Indicate desired polarity by suffixing model number with -P or -N (i.e. positive or negative) or -PN for dual polarity option.
- 6) The supplied test load is for low-duty-cycle basic operational tests only. The power rating of the load is 5 Watts. It is not capable of supporting the instrument's full maximum average output power. See <http://www.avtechpulse.com/accessories/> for details about the AV-CTL series of test loads.
- 7) The AVOZ-B4-B requires a user-supplied 0 to 110V DC power supply that is capable of supplying the maximum average power output of the instrument (i.e., 400 Watts worst-case). The polarity of the power supply must be the same as that of the AVOZ-B4-B. The Xantrex (<http://www.xantrex.com/>) XHR 150-7 is one example of a suitable power supply.
- 8) Multi-Contact (<http://www.multi-contact.com> or <http://www.multi-contact-usa.com>) ID/S6AR-N-B4S series, or similar. For mating cables, specify the -AK3 option, which includes two 1m cables (1 red, 1 black) with 6mm safety sockets, and two 6mm safety plug to M6 stud adapters (1 red, 1 black).
- 9) Measured when the load resistance is equal to the minimum rated load impedance.
- 10) Typically < 10 ns measured at rear-panel output connector. The supplied AV-CLZ11-60 cable, if used, will degrade the rise and fall times to < 15 ns, approximately.
- 11) The maximum and actual amplitudes will fall by up to 25% for pulse widths less than 3 times the specified rise/fall time, due to the "rounding" of the pulse.

- 12) The amplitude may decrease ~10% relative to the programmed setting if the instrument is operating at or near the maximum specified duty cycle.
- 13) These instruments are provided with a basic calibration checksheet, showing a selection of measured output parameters. These measurements are performed with equipment that is calibrated on a regular basis by a third-party ISO/IEC 17025:2005 accredited calibration laboratory. However, Avtech itself does not claim any accreditation. For applications requiring traceable performance, use a calibrated measurement system rather than relying on the accuracy of the pulse generator settings.

REGULATORY NOTES

FCC PART 18

This device complies with part 18 of the FCC rules for non-consumer industrial, scientific and medical (ISM) equipment.

This instrument is enclosed in a rugged metal chassis and uses a filtered power entry module (where applicable). The main output signal is provided on a shielded connector that is intended to be used with shielded coaxial cabling and a shielded load. Under these conditions, the interference potential of this instrument is low.

If interference is observed, check that appropriate well-shielded cabling is used on the output connectors. Contact Avtech (info@avtechpulse.com) for advice if you are unsure of the most appropriate cabling. Also, check that your load is adequately shielded. It may be necessary to enclose the load in a metal enclosure.

If any of the connectors on the instrument are unused, they should be covered with shielded metal "dust caps" to reduce the interference potential.

This instrument does not normally require regular maintenance to minimize interference potential. However, if loose hardware or connectors are noted, they should be tightened. Contact Avtech (info@avtechpulse.com) if you require assistance.

EC DECLARATION OF CONFORMITY



We Avtech Electrosystems Ltd.
 P.O. Box 5120, LCD Merivale
 Ottawa, Ontario
 Canada K2C 3H5

declare that this pulse generator meets the intent of Directive 2004/108/EG for Electromagnetic Compatibility. Compliance pertains to the following specifications as listed in the official Journal of the European Communities:

EN 50081-1 Emission

EN 50082-1 Immunity

and that this pulse generator meets the intent of the Low Voltage Directive 2006/95/EC. Compliance pertains to the following specifications as listed in the official Journal of the European Communities:

EN 61010-1:2001 Safety requirements for electrical equipment for measurement, control, and laboratory use

DIRECTIVE 2011/65/EU (RoHS)

We Avtech Electrosystems Ltd.
P.O. Box 5120, LCD Merivale
Ottawa, Ontario
Canada K2C 3H5

declare that, to the best of our knowledge, all electrical and electronic equipment (EEE) sold by the company are in compliance with Directive 2011/65/EU of the European Parliament and of the Council of 8 June 2011 on the restriction of the use of certain hazardous substances in electrical and electronic equipment (also known as “RoHS Recast”). In addition, this declaration of conformity is issued under the sole responsibility of Avtech Electrosystems Ltd. Specifically, products manufactured do not contain the substances listed in the table below in concentrations greater than the listed maximum value.

<i>Material/Substance</i>	<i>Threshold level</i>
Lead (Pb)	< 1000 ppm (0.1% by mass)
Mercury (Hg)	< 1000 ppm (0.1% by mass)
Hexavalent Chromium (Cr6+)	< 1000 ppm (0.1% by mass)
Polybrominated Biphenyls (PBB)	< 1000 ppm (0.1% by mass)
Polybrominated Diphenyl ethers (PBDE)	< 1000 ppm (0.1% by mass)
Cadmium (Cd)	< 100 ppm (0.01% by mass)
Bis(2-ethylhexyl) phthalate (DEHP)	< 1000 ppm (0.1% by mass)
Butyl benzyl phthalate (BBP)	< 1000 ppm (0.1% by mass)
Dibutyl phthalate (DBP)	< 1000 ppm (0.1% by mass)
Diisobutyl phthalate (DIBP)	< 1000 ppm (0.1% by mass)

DIRECTIVE 2002/96/EC (WEEE)

European customers who have purchased this equipment directly from Avtech will have completed a “WEEE Responsibility Agreement” form, accepting responsibility for WEEE compliance (as mandated in Directive 2002/96/EC of the European Union and local

laws) on behalf of the customer, as provided for under Article 9 of Directive 2002/96/EC.

Customers who have purchased Avtech equipment through local representatives should consult with the representative to determine who has responsibility for WEEE compliance. Normally, such responsibilities will lie with the representative, unless other arrangements (under Article 9) have been made.

Requirements for WEEE compliance may include registration of products with local governments, reporting of recycling activities to local governments, and financing of recycling activities.

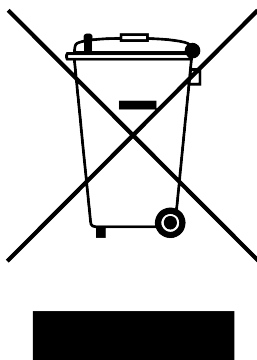

FIRMWARE LICENSING

Instruments with firmware versions 5.00 or higher use open-source software internally. Some of this software requires that the source code be made available to the user as a condition of its licensing. This source code is available upon request (contact info@avtechpulse.com).

Earlier firmware versions do not contain any open source software.

INSTALLATION

VISUAL CHECK

After unpacking the instrument, examine to ensure that it has not been damaged in shipment. Visually inspect all connectors, knobs, liquid crystal displays (LCDs), and the handles. If the instrument has been damaged, file a claim immediately with the company that transported the instrument.

Confirm that the following items are present:

- The mainframe (i.e., the main instrument chassis)
- A power cord
- A GPIB cable
- An AV-CTL1-ENC test load
- An AV-CLZ1-60 transmission line cable assembly
- Two instrumentation manuals (this manual and the “Programming Manual for -B Instruments”) are with the instrument.

POWER RATINGS

This instrument is intended to operate from 100 - 240 V, 50 - 60 Hz.

The maximum power consumption is 74 Watts. Please see the “FUSES” section for information about the appropriate AC and DC fuses.

This instrument is an “Installation Category II” instrument, intended for operation from a normal single-phase supply.

CONNECTION TO THE POWER SUPPLY

An IEC-320 three-pronged recessed male socket is provided on the back panel for AC power connection to the instrument. One end of the detachable power cord that is supplied with the instrument plugs into this socket. The other end of the detachable power cord plugs into the local mains supply. Use only the cable supplied with the instrument. The mains supply must be earthed, and the cord used to connect the instrument to the mains supply must provide an earth connection. (The supplied cord does this.)

 Warning: Failure to use a grounded outlet may result in injury or death due to electric shock. This product uses a power cord with a ground connection. It must be connected to a properly grounded outlet. The instrument chassis is connected to the ground wire in the power cord.

The table below describes the power cord that is normally supplied with this instrument, depending on the destination region:

Destination Region	Description	Option	Manufacturer	Part Number
United Kingdom, Hong Kong, Singapore, Malaysia	BS 1363, 230V, 50 Hz	-AC00	Qualtek	370001-E01
Australia, New Zealand	AS 3112:2000, 230-240V, 50 Hz	-AC01	Qualtek	374003-A01
Continental Europe, Korea, Indonesia, Russia	European CEE 7/7 "Schuko" 230V, 50 Hz	-AC02	Qualtek	364002-D01
North America, Taiwan	NEMA 5-15, 120V, 60 Hz	-AC03	Qualtek	312007-01
Switzerland	SEV 1011, 230V, 50 Hz	-AC06	Qualtek	378001-E01
South Africa, India	SABS 164-1, 220-250V, 50 Hz	-AC17	Volex	2131H 10 C3
Japan	JIS 8303, 100V, 50-60 Hz	-AC18	Qualtek	397002-01
Israel	SI 32, 220V, 50 Hz	-AC19	Qualtek	398001-01
China	GB 1002-1 / 2099-1, 220V, 50 Hz	-AC22	Qualtek	399012-01

PROTECTION FROM ELECTRIC SHOCK

 Operators of this instrument must be protected from electric shock at all times. The owner must ensure that operators are prevented access and/or are insulated from every connection point. In some cases, connections must be exposed to potential human contact. Operators must be trained to protect themselves from the risk of electric shock. This instrument is intended for use by qualified personnel who recognize shock hazards and are familiar with safety precautions required to avoid possibly injury. In particular, operators should:

1. Keep exposed high-voltage wiring to an absolute minimum.
2. Wherever possible, use shielded connectors and cabling.
3. Connect and disconnect loads and cables only when the instrument is turned off.
4. Keep in mind that all cables, connectors, oscilloscope probes, and loads must have an appropriate voltage rating.

5. Do not attempt any repairs on the instrument, beyond the fuse replacement procedures described in this manual. Contact Avtech technical support (see page 2 for contact information) if the instrument requires servicing. Service is to be performed solely by qualified service personnel.

ENVIRONMENTAL CONDITIONS

This instrument is intended for use under the following conditions:

1. indoor use;
2. altitude up to 2 000 m;
3. temperature 5 °C to 40 °C;
4. maximum relative humidity 80 % for temperatures up to 31 °C decreasing linearly to 50 % relative humidity at 40 °C;
5. Mains supply voltage fluctuations up to ± 10 % of the nominal voltage;
6. no pollution or only dry, non-conductive pollution.

LABVIEW DRIVERS

A LabVIEW driver for this instrument is available for download on the Avtech web site, at <http://www.avtechpulse.com/labview>. A copy is also available in National Instruments' Instrument Driver Library at <http://www.natinst.com/>.

FUSES

This instrument contains four fuses. All are accessible from the rear-panel. Two protect the AC prime power input, and two protect the internal DC power supplies. The locations of the fuses on the rear panel are shown in the figure below:

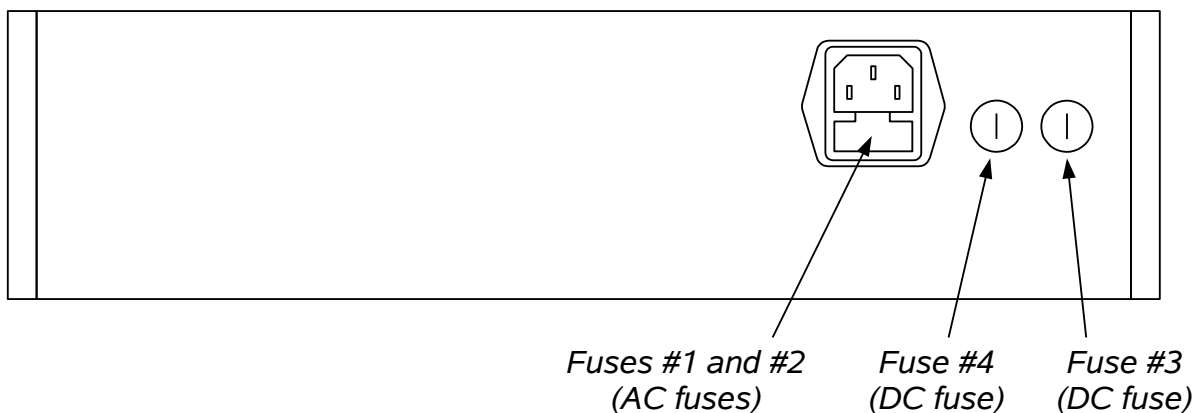

AC FUSE REPLACEMENT

To physically access the AC fuses, the power cord must be detached from the rear panel of the instrument. The fuse drawer may then be extracted using a small flat-head screwdriver, as shown below:

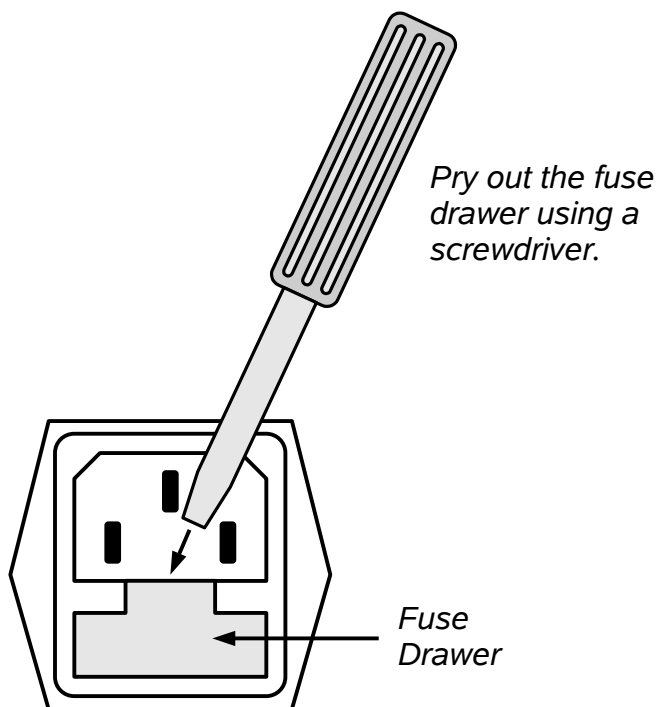

DC FUSE REPLACEMENT

The DC fuses may be replaced by inserting the tip of a flat-head screwdriver into the fuse holder slot, and rotating the slot counter-clockwise. The fuse and its carrier will then pop out.

FUSE RATINGS

The following table lists the required fuses:

Fuses	Nominal Mains Voltage	Rating	Case Size	Recommended Replacement Part	
				Littelfuse Part Number	Digi-Key Stock Number
#1, #2 (AC)	100-240V	0.5A, 250V, Time-Delay	5×20 mm	0218.500HXP	F2416-ND
#3 (DC)	N/A	0.8A, 250V, Time-Delay	5×20 mm	0218.800HXP	F2418-ND
#4 (DC)	N/A	1.6A, 250V, Time-Delay	5×20 mm	021801.6HXP	F2424-ND

The recommended fuse manufacturer is Littelfuse (<http://www.littelfuse.com>).

Replacement fuses may be easily obtained from Digi-Key (<http://www.digikey.com>) and other distributors.

FRONT PANEL CONTROLS

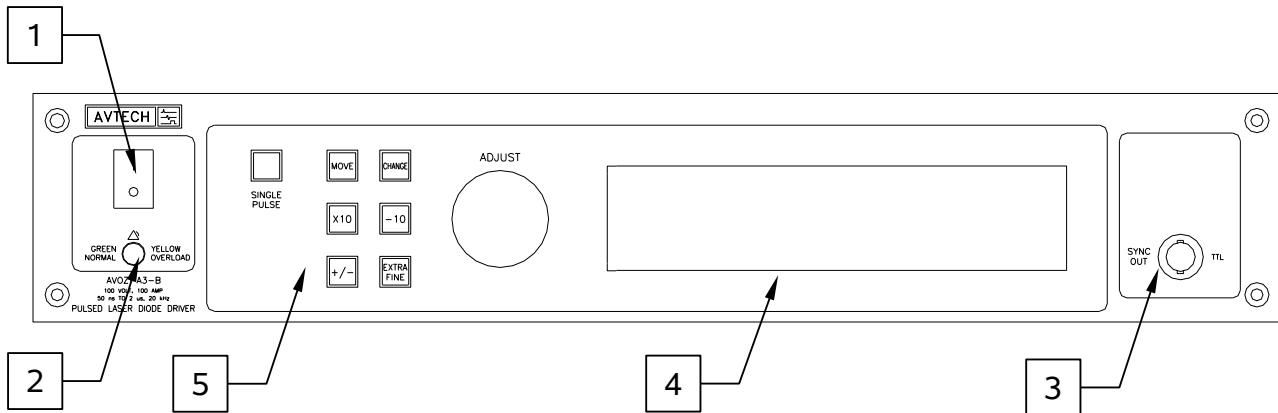

1. **POWER Switch**. This is the main power switch. When turning the instrument on, there is normally a delay of 10 seconds before anything is shown on the main display, as the internal operating system boots up.
2. **OVERLOAD Indicator**. When the instrument is powered, this indicator is normally green, indicating normal operation. If this indicator is yellow, an internal automatic overload protection circuit has been tripped. If the unit is overloaded (by operating at an exceedingly high duty cycle or by operating into a very low impedance), the protective circuit will disable the output of the instrument and turn the indicator light yellow. The light will stay yellow (i.e. output disabled) for about 5 seconds after which the instrument will attempt to re-enable the output (i.e. light green) for about 1 second. If the overload condition persists, the output will be disabled again (i.e. light yellow) for another 5 seconds. If the overload condition has been removed, the instrument will resume normal operation.

This overload indicator may flash yellow briefly at start-up. This is not a cause for concern.

3. **SYNC OUT**. This connector supplies a SYNC output that can be used to trigger other equipment, particularly oscilloscopes. This signal leads (or lags) the main output by a duration set by the "DELAY" controls and has an approximate amplitude of +3 Volts to $R_L > 50\Omega$ with a pulse width of approximately 100 ns.
4. **LIQUID CRYSTAL DISPLAY (LCD)**. This LCD is used in conjunction with the keypad to change the instrument settings. Normally, the main menu is displayed, which lists the key adjustable parameters and their current values. The "Programming Manual for -B Instruments" describes the menus and submenus in detail.

5. KEYPAD.

Control Name	Function
MOVE	This moves the arrow pointer on the display.
CHANGE	This is used to enter the submenu, or to select the operating mode, pointed to by the arrow pointer.
×10	If one of the adjustable numeric parameters is displayed, this increases the setting by a factor of ten.
÷10	If one of the adjustable numeric parameters is displayed, this decreases the setting by a factor of ten.
+/-	If one of the adjustable numeric parameters is displayed, and this parameter can be both positive or negative, this changes the sign of the parameter.
EXTRA FINE	This changes the step size of the ADJUST knob. In the extra-fine mode, the step size is twenty times finer than in the normal mode. This button switches between the two step sizes.
ADJUST	This large knob adjusts the value of any displayed numeric adjustable values, such as frequency, pulse width, etc. The adjust step size is set by the "EXTRA FINE" button. When the main menu is displayed, this knob can be used to move the arrow pointer.

REAR PANEL CONTROLS

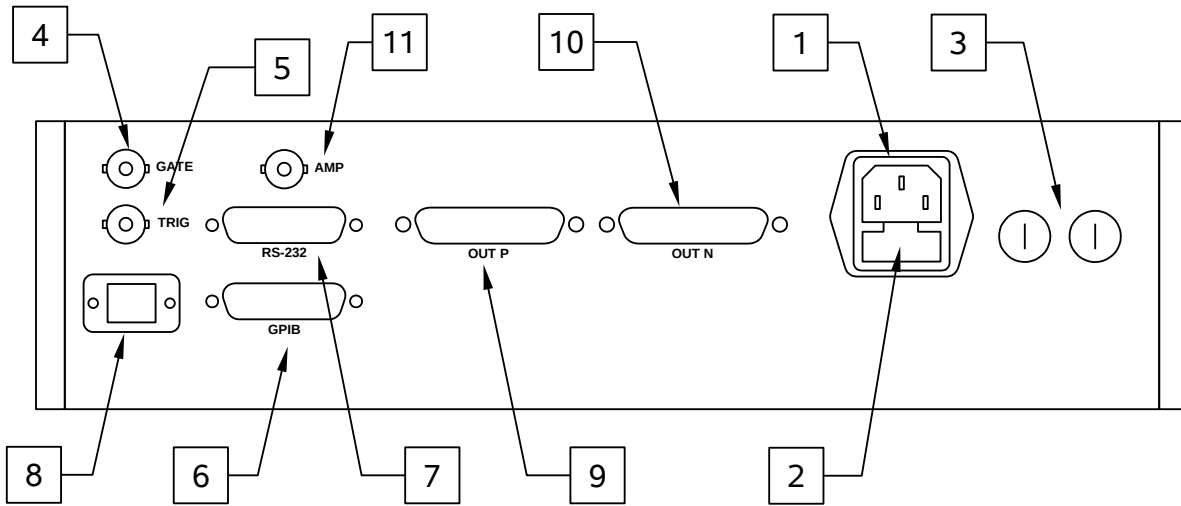

1. AC POWER INPUT. An IEC-320 C14 three-pronged recessed male socket is provided on the back panel for AC power connection to the instrument. One end of the detachable power cord that is supplied with the instrument plugs into this socket.
2. AC FUSE DRAWER. The two fuses that protect the AC input are located in this drawer. Please see the “FUSES” section of this manual for more information.
3. DC FUSES. These two fuses protect the internal DC power supplies. Please see the “FUSES” sections of this manual for more information.
4. GATE. This TTL-level (0 and +5V) logic input can be used to gate the triggering of the instrument. This input can be either active high or active low, depending on the front panel settings or programming commands. (The instrument triggers normally when this input is unconnected). When set to active high mode, this input is pulled-down to ground by a 1 k Ω resistor. When set to active low mode, this input is pulled-up to +5V by a 1 k Ω resistor.
5. TRIG. This TTL-level (0 and +5V) logic input can be used to trigger the instrument, if the instrument is set to triggering externally. The instrument triggers on the rising edge of this input. The input impedance of this input is 1 k Ω . (Depending on the length of cable attached to this input, and the source driving it, it may be desirable to add a coaxial 50 Ohm terminator to this input to provide a proper transmission line termination. The Pasternack (www.pasternack.com) PE6008-50 BNC feed-thru 50 Ohm terminator is suggested for this purpose.)
6. GPIB Connector. A standard GPIB cable can be attached to this connector to allow the instrument to be computer-controlled. See the “Programming Manual for -B Instruments” for more details on GPIB control.

7. RS-232 Connector. A standard serial cable with a 25-pin male connector can be attached to this connector to allow the instrument to be computer-controlled. A user name (“admin”) and a password (“default”, as shipped from the factory) are required when logging into a serial terminal session. The internal controller attempts to auto-sense the parity setting. It may be necessary to send a few return characters before attempting a login in order to provide enough data to allow this auto-sensing to work. (A standard Linux “agetty” process is used to implement serial control internally.) See the “Programming Manual for -B Instruments” for more details on RS-232 control.
8. Network Connector. This Ethernet connector allows the instrument to be remotely controlled using the VXI-11.3, ssh (secure shell), telnet, and http (web) protocols. See the “Programming Manual for -B Instruments” for more details.
9. OUT P. This is the main positive output, present on “-P” and “-PN” units. It is only active when the amplitude is set to a positive value. The AV-CLZ1-60 transmission line plugs into this DB-37 female connector. Pins 1-19 (the upper row) are connected to the signal out, and pins 20-37 (the lower row) are connected to ground.

 Caution: Voltages as high as 100V may be present on the pins 1-19 of this output connector. Avoid touching these conductors. Ensure that any cable, load, or system connecting to this connector shields the high-voltage areas from the user.

10. OUT N. This is the main negative output, present on “-N” and “-PN” units. It is only active when the amplitude is set to a negative value. The AV-CLZ1-60 transmission line plugs into this DB-37 female connector. Pins 1-19 (the upper row) are connected to the signal out, and pins 20-37 (the lower row) are connected to ground.

 Caution: Voltages as high as 100V may be present on the pins 1-19 of this output connector. Avoid touching these conductors. Ensure that any cable, load, or system connecting to this connector shields the high-voltage areas from the user.

11. AMP Connector. (Optional feature. Present on -EA units only.) The output amplitude can be set to track the voltage on this input. Zero Volts in corresponds to zero amplitude output, and +10V in corresponds to maximum amplitude out. This mode is activated by selecting "Ext Control" on the front-panel amplitude menu, or with the "source:voltage external" command.

GENERAL INFORMATION - PULSE GENERATOR TIMING

BASIC PULSE CONTROL

This instrument can be triggered by its own internal clock or by an external TTL trigger signal. In either case, two output channels respond to the trigger: OUT and SYNC. The OUT channel is the signal that is applied to the device under test. Its amplitude and pulse width are variable. The SYNC pulse is a fixed-width TTL-level reference pulse used to trigger oscilloscopes or other measurement systems. When the delay is set to a positive value the SYNC pulse precedes the OUT pulse.

In the diagrams below, positive amplitude is assumed. (For “-N” units, the output waveforms are inverted in polarity.)

These pulses are illustrated below for a positive delay, and internal triggering:

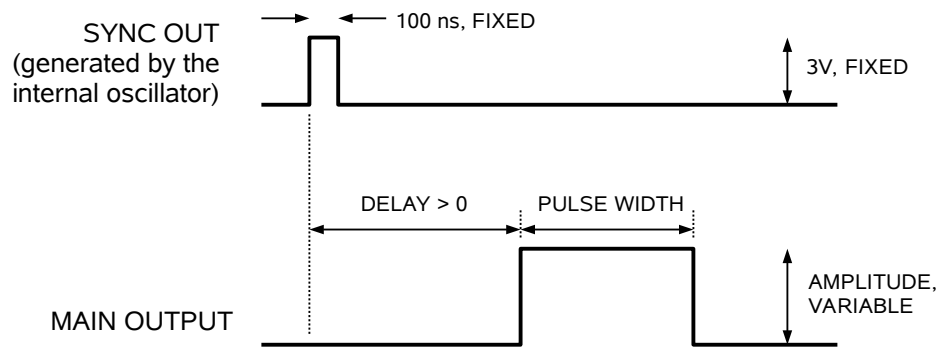

Basic Output Pulses for Delay > 0

The order of the output pulses is reversed for negative delays:

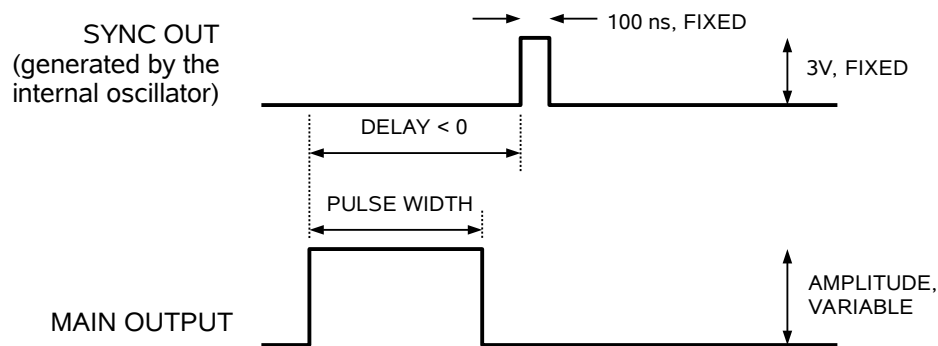

Basic Output Pulses for Delay < 0

When the triggering is set to external mode, a TTL-level pulse on the TRIG input will trigger the pulse generator, as shown below:

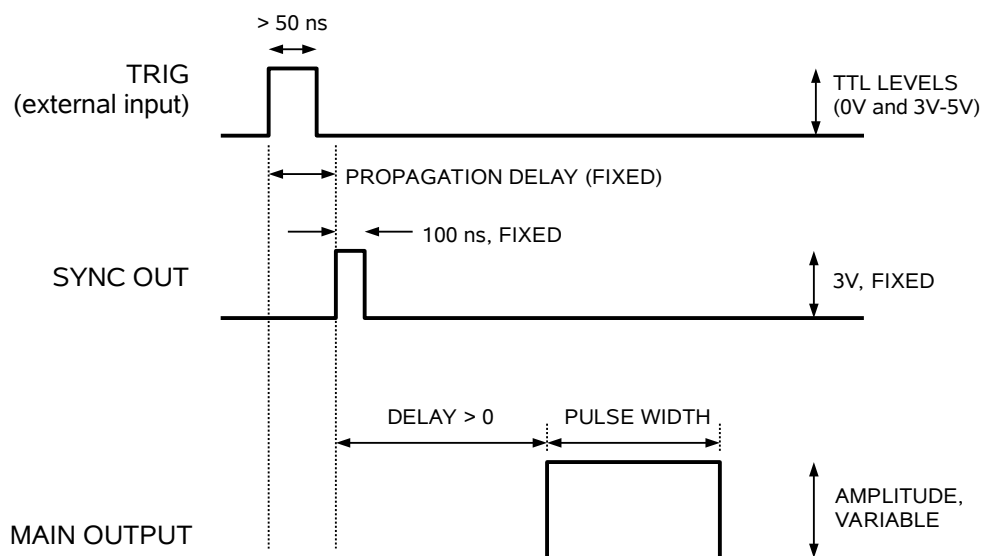

As before, if the delay is negative, the order of the SYNC and OUT pulses is reversed.

TRIGGER MODES

This instrument has four trigger modes:

- Internal Trigger: the instrument controls the trigger frequency, and generates the clock internally.
- External Trigger: the instrument is triggered by an external TTL-level clock on the back-panel TRIG connector.
- Manual Trigger: the instrument is triggered by the front-panel “SINGLE PULSE” pushbutton.
- Hold Trigger: the instrument is set to not trigger at all.

These modes can be selected using the front panel trigger menu, or by using the appropriate programming commands. (See the “Programming Manual for -B Instruments” for more details.)

GATING MODES

Triggering can be suppressed by a TTL-level signal on the rear-panel GATE connector. The instrument can be set to stop triggering when this input high or low, using the front-panel gate menu or the appropriate programming commands. This input can also be set to act synchronously or asynchronously. When set to asynchronous mode, the GATE will disable the output immediately. Output pulses may be truncated. When set to

synchronous mode, the output will complete the full pulse width if the output is high, and then stop triggering. No pulses are truncated in this mode.

GENERAL INFORMATION - OPERATING INTO A LOAD

AMPLITUDE CONTROL

The Model AVOZ-A3-B pulse generator is a voltage pulser. The current amplitude is determined by Ohm's Law. That is, the current is the output voltage divided by the load resistance. More specifically:

$$I_{OUT} = (V_{SETTING} - V_{DIODE}) / R,$$

where $V_{SETTING}$ is the set amplitude, V_{DIODE} is the diode voltage, and R is the series resistance (including any series resistance in the diode itself). R is normally 1 Ω ; it should not be smaller than this. Avtech recommends connecting multiple Ohmite OX or OY-series or RCD RSF2B resistors in parallel to create a high-power, low-inductance effective resistance.

SELECTING THE SERIES RESISTANCE

The best waveforms will be obtained if the amplitude is set between 20% and 100% of the maximum rating (i.e., 20V to 100V), and if the load resistance R is chosen to be between 1.0 and 1.6 Ohms.

It should never be less than 1.0 Ω , or the instrument may be damaged.

For applications requiring less than the maximum possible current, best results may be obtained if R is approximately 1.6 Ω , because this slight increase in the load resistance will result in a faster transition times. However, the load resistance should not be increased beyond 1.6 Ω , or the transmission line mismatch between the output transmission line (which has a characteristic impedance of $Z_0 = 1 \Omega$) and the load may introduce significant ringing.

If the resistance of the device under test (DUT) is significantly higher than 1.6 Ω , resistance should be added in parallel with the DUT so that the total equivalent resistance is 1.6 Ω .

OUTPUT CONNECTIONS

The main output is provided on a rear-panel DB-37 female connector. Pins 1-19 of this connector (the upper row) are connected to the signal out, and pins 20-37 (the lower row) are connected to ground.

An AV-CLZ1-60 transmission line is supplied with the instrument. One end plugs into the rear-panel connector. The other end is terminated with a DB-37 male connector. Pins 1-19 of this connector (the upper row) are connected to the signal out, and pins 20-37 (the lower row) are connected to ground. The cable is reversible - either end can be plugged into the rear panel. This cable can be ordered separately, as model AV-

CLZ1-60. (Lengths longer than 60 cm are also available - see <http://www.avtechpulse.com/transmission/av-clz1> for details.)

The user may connect a load to the end of the AV-CLZ1-60 transmission line using a load that has a DB-37 female connector. To construct your own connectorized load, consider using a Norcomp 172-037-201-001 DB-37 female connector with solder cup pins. This is readily available from Digi-Key (<http://www.digikey.com>, stock number 137F-ND). Care must be taken to construct the connectorized test load to conform to local safety standards. High voltages (up to 100V, approximately) will be present on the load during normal operation. Pins 1-19 should be connected together to provide the signal output, and pins 20-37 should be connected together to provide the ground.

It may be simpler to modify the supplied test load. The supplied test load has this connector pre-installed, and a safety enclosure is provided. This test load is described in the next section.

 Caution: Voltages as high as 100V may be present on the pins 1-19 of the output connector. Avoid touching these conductors. Ensure that any cable, load, or system connecting to this connector shields the high-voltage areas from the user.

USING THE SUPPLIED TEST LOAD (AV-CTL1-ENC)

The supplied test load consists of a DB-37 female connector mounted on the lid of a small aluminum box chassis. Inside the chassis, an 8 mm by 50 mm circuit board is sandwiched between the two rows of solder cups on the rear of the connector. Four Ohmite OY-series 3.9 Ohm resistors are connected in parallel between the two rows of solder cups. This provides a total resistance of $3.9 \Omega / 4 \approx 1.0 \Omega$.

Two unused SMA connectors are provided for making connections through the chassis wall, if desired. A 5/16" hole, plugged with a screw is also provided. The screw may be removed to provide an access hole to the interior of the chassis.

Due to the presence of high voltages on the output (up to 100V, approximately), the lid should be installed on the aluminum chassis so that users can not physically touch the load.

The test load has a maximum power dissipation rating of 5 Watts. Take care not exceed this!

This test load can be ordered separately, as model AV-CTL1-ENC. It can also be ordered with no resistors installed, as model AV-CTLX-ENC.

The basic mechanical connection scheme for the AV-CTL1-ENC is shown below:

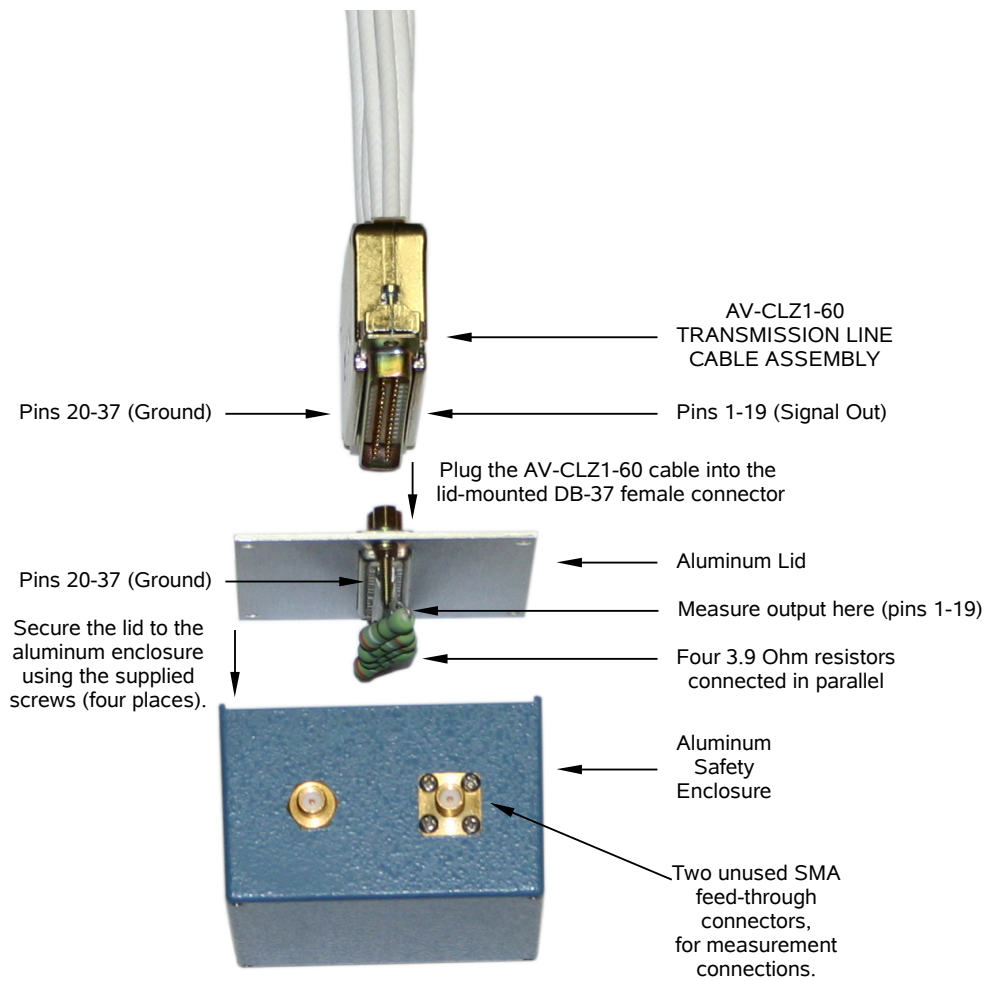

TEST ARRANGEMENT

The basic test arrangement is shown below:

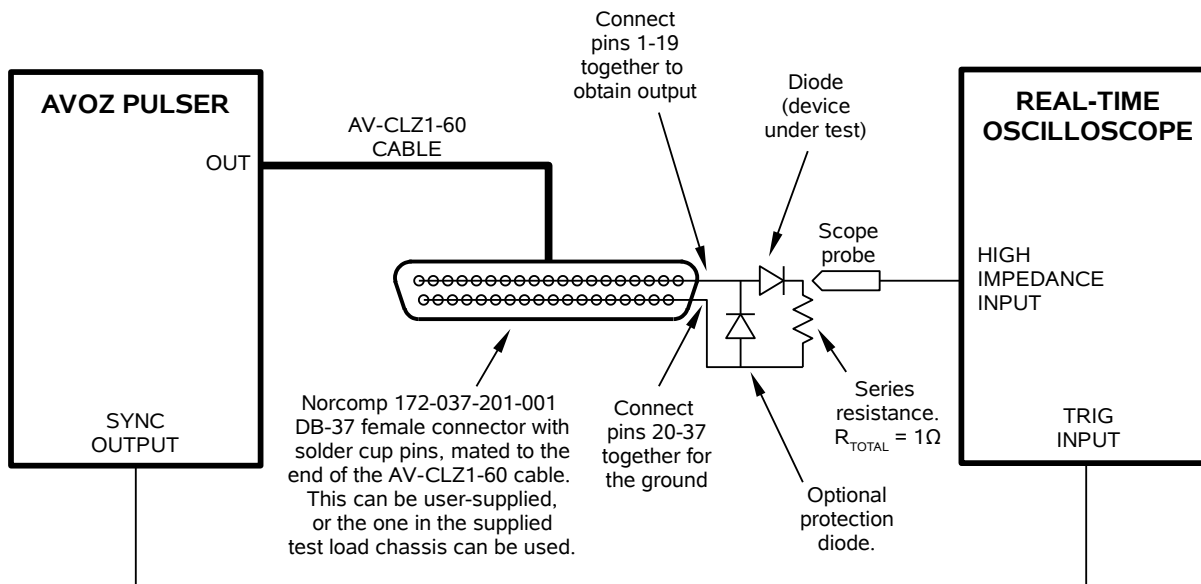

NOTE: BOTH DIODES ARE SHOWN ORIENTED FOR A POSITIVE OUTPUT. REVERSE BOTH DIODES FOR NEGATIVE OPERATION.

The diagram above shows how high-impedance oscilloscope probe can be used to observe the waveform. However, since the load impedance is so low (1 Ohm), a 50 Ohm measurement system like that shown in the diagram below can also be used to observe the load waveform. An attenuator should be used to avoid damaging the oscilloscope input, since the load voltage can be as high as 100V. (Two SMA connectors are present in the AV-CTL1-ENC test load, and either can be used to connect the 50 Ohm coaxial cables through the chassis wall.)

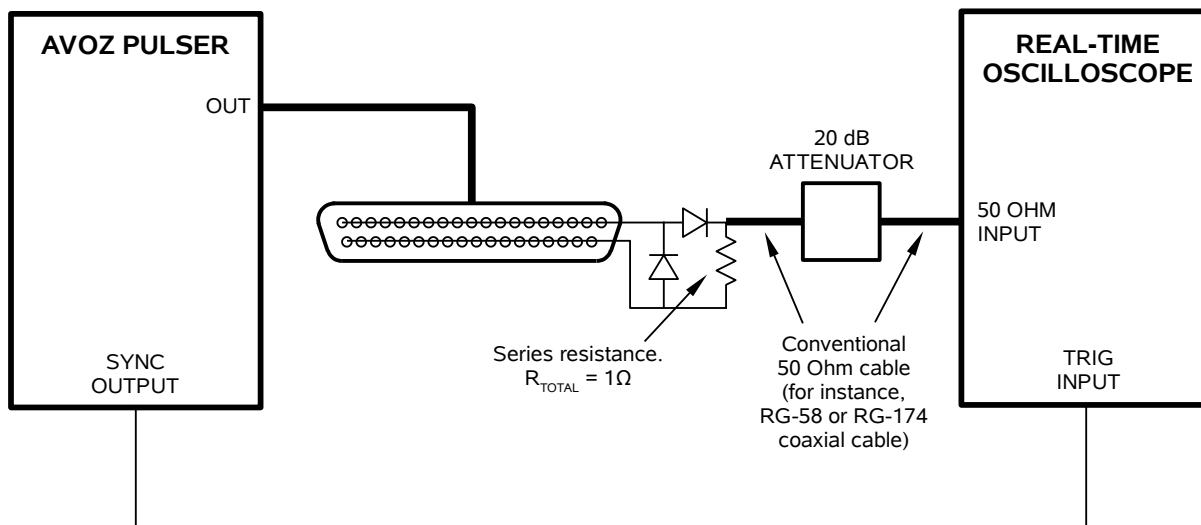

The diodes are shown oriented for positive polarity. Reverse them for negative polarity models.

There are several key points to note. As explained above, a resistance should be added in series with the diode load, to limit the maximum current. This resistance may also be used to monitor the current through the diode current. If connected as shown above, the resistor voltage displayed on the oscilloscope is directly proportional to the diode current. It is essential the low-inductance resistors be used. Several non-inductive, medium power resistors should be used in parallel (for instance, four 3.9 Ohm 2W resistors). The Ohmite OY series (www.ohmite.com) or the RCD RSF2B series (www.rcd-comp.com) are appropriate.

It is also recommended that a low-capacitance, high-voltage, ultra-fast Schottky rectifier diode be connected for reverse-bias protection, especially for sensitive or costly devices under test. The STMicroelectronics (www.st.com) STPS3150 is an example of a suitable diode. Note, however, that the capacitance added by the protection diode may degrade the output rise time slightly.

LENZ'S LAW AND INDUCTIVE VOLTAGE SPIKES

This instrument is designed to pulse resistive and diode loads and will exhibit a large output spike when used to drive a load with significant inductance (as predicted by LENZ'S LAW). For this reason the load should be connected to the output using low inductance leads (as short as possible and as heavy a gauge as possible).

The voltage developed across an inductance L (in Henries), when the current is changing at a rate given by di_{LOAD}/dt (in Amps/sec), is: $V_{SPIKE} = L \times di_{LOAD}/dt$.

For this reason, the length of leads used to connect the load to the circuit board should be kept extremely short (< 0.5 cm).

ATTACHING AND DETACHING LOADS

To avoid damaging the loads connected to main outputs, the loads should only be connected to or removed from the instrument when the instrument is off. Do not connect loads when the instrument is on and the output amplitude is not zero. This can cause sparking.

MEASURING OUTPUT CURRENT

Two basic methods can be used to observe the current waveform through the load. The first is to observe the voltage waveform across the resistance present in the load. If the resistance is non-inductive, the voltage waveform will be directly proportional to the current waveform (Ohm's Law). Keeping the parasitic inductance low is critical for reliable measurements. If a diode is connected in series with the resistance, it may be

advantageous to ensure the diode is placed before the resistance, so that one end of the resistance is grounded. This will eliminate the need for differential voltage measurements. This method is shown in the "TEST ARRANGEMENT" section above.

Alternatively, a high-speed current probe or current transformer can be used to observe the current waveform. One possible model is the Pearson 2878 current transformer (<http://www.pearsonelectronics.com>). However, this model will not operate at the upper end of the AVOZ-A3-B pulse width range (2 us). It may be necessary to introduce a significant lead length (i.e., inductance) to pass the conductor through the transformer.

START-UP CHECK-LIST FOR LOCAL CONTROL

1. Connect the supplied test load (AV-CTL1-ENC) to the rear-panel of the mainframe, using the AV-CLZ1-60 cable.
2. Connect a cable from the SYNC OUT connector to the TRIG input of an oscilloscope. Set the oscilloscope to trigger externally.
3. Connect an oscilloscope probe to the signal side of the resistors in the test load. It may be necessary to connect the probe using the SMA feed-throughs on the test load enclosure. On the oscilloscope, set the channel A vertical scale to 20 V/div, and the horizontal scale to 100 ns/div. (A 50 Ohm measurement system, without a high impedance probe, can also be used if desired. This may be more mechanically convenient. See the "TEST ARRANGEMENT" section for details.)
4. Turn on the instrument. The main menu will appear on the LCD.
5. To set the instrument to trigger from the internal clock at a PRF of 1 kHz:
 - a) The arrow pointer should be pointing at the frequency menu item. If it is not, press the MOVE button until it is.
 - b) Press the CHANGE button. The frequency submenu will appear. Rotate the ADJUST knob until the frequency is set at 1 kHz.
 - c) The arrow pointer should be pointing at the "Internal" choice. If it is not, press MOVE until it is.
 - d) Press CHANGE to return to the main menu.
6. To set the delay to 100 ns:
 - a) Press the MOVE button until the arrow pointer is pointing at the delay menu item.
 - b) Press the CHANGE button. The delay submenu will appear. Rotate the ADJUST knob until the delay is set at 100 ns.
 - c) Press CHANGE to return to the main menu.
7. To set the OUT pulse width to 500 ns:
 - a) Press the MOVE button until the arrow pointer is pointing at the "PW" menu item.

- b) Press the CHANGE button. The pulse width submenu will appear. Rotate the ADJUST knob until the pulse width is set at 500 ns.
 - c) The arrow pointer should be pointing at the “Normal” choice. If it is not, press MOVE until it is.
 - d) Press CHANGE to return to the main menu.
8. At this point, nothing should appear on the oscilloscope.
9. To enable the output:
- a) Press the MOVE button until the arrow pointer is pointing at the output menu item.
 - b) Press the CHANGE button. The output submenu will appear.
 - c) Press MOVE until the arrow pointer is pointing at the “ON” choice.
 - d) Press CHANGE to return to the main menu.
10. To change the OUT output amplitude:
- a) Press the MOVE button until the arrow pointer is pointing at the AMP menu item.
 - b) Press the CHANGE button. The amplitude submenu will appear. Rotate the ADJUST knob until the amplitude is set at 100 V (or -100V for “-N” units).
 - c) Observe the oscilloscope. You should see 500 ns wide, 100V pulses on the probe connected to the main output.
 - d) Press CHANGE to return to the main menu.
11. Try varying the pulse width, by repeating step (7). As you rotate the ADJUST knob, the pulse width on the oscilloscope will change. It should agree with the displayed value.
12. This completes the operational check.

CALIBRATION ADJUSTMENTS - SOFTWARE PROCEDURES

ADJUSTING AMPLITUDE ACCURACY

If it is found that the output amplitude settings (as set by the front-panel controls or programming commands) do not agree exactly with measured values of amplitude (i.e., by examining the output on an oscilloscope), the amplitude calibration can be updated using software commands.

The following procedure is suggested:

- 1) Connect a 1 Ω high-power resistive load to the output.
- 2) Connect the pulse generator to a computer using the GPIB or RS232 ports.
- 3) Turn on the pulse generator, and set the time controls (frequency, delay, pulse width) to typical values.
- 4) Turn on the outputs.
- 5) Set the output amplitude to 100V.
- 6) Observe the voltage across the load. (For example, suppose it is 104V).
- 7) Send the measured value to the instrument using the following command:

```
diag:ampl:cal 104
```

The internal software compares the supplied measured value to the programmed value, and adjusts the internal calibration data to null out any differences.

- 8) Observe the voltage across the load again. The amplitude setting should now agree with the measured value.

Information on more extensive timing and amplitude calibration procedures is available at <http://www.avtechpulse.com/appnote/>.

PROGRAMMING YOUR PULSE GENERATOR

KEY PROGRAMMING COMMANDS

The “Programming Manual for -B Instruments” describes in detail how to connect the pulse generator to your computer, and the programming commands themselves. A large number of commands are available; however, normally you will only need a few of these. Here is a basic sample sequence of commands that might be sent to the instrument after power-up:

*rst	(resets the instrument)
trigger:source internal	(selects internal triggering)
frequency 10 Hz	(sets the frequency to 10 Hz)
pulse:width 100 ns	(sets the pulse width to 100 ns)
pulse:delay 1 us	(sets the delay to 1 us)
output on	(turns on the output)
source:volt 50V	(sets the voltage amplitude to 50 Volts)

For triggering a single event, this sequence would be more appropriate:

*rst	(resets the instrument)
trigger:source hold	(turns off all triggering)
pulse:width 100 ns	(sets the pulse width to 100 ns)
output on	(turns on the output)
source:volt 50V	(sets the voltage amplitude to 50 Volts)
trigger:source immediate	(generates a single non-repetitive trigger event)
trigger:source hold	(turns off all triggering)
output off	(turns off the output)

To set the instrument to trigger from an external TTL signal applied to the rear-panel TRIG connector, use:

*rst	(resets the instrument)
trigger:source external	(selects external triggering)
pulse:width 100 ns	(sets the pulse width to 100 ns)
pulse:delay 1 us	(sets the delay to 1 us)
source:volt 50V	(sets the voltage amplitude to 50 Volts)
output on	(turns on the output)

These commands will satisfy 90% of your programming needs.

ALL PROGRAMMING COMMANDS

For more advanced programmers, a complete list of the available commands is given below. These commands are described in detail in the “Programming Manual for -B Instruments”. (Note: this manual also includes some commands that are not implemented in this instrument. They can be ignored.)

<u>Keyword</u>	<u>Parameter</u>	<u>Notes</u>
DIAGnostic:		
:AMPLitude		
:CALibration:	<numeric value>	[no query form]
OUTPut:		
:[STATe]	<boolean value>	
:PROTection		
:TRIPped?		[query only]
[SOURce]:		
:FREQuency		
[:CW FIXed]	<numeric value>	
[SOURce]:		
:VOLTage		
[:LEVel]		
[:IMMediate]		
[:AMPLitude]	<numeric value> EXTernal	
:PROTection		
:TRIPped?		[query only]
[SOURce]:		
:PULSE		
:PERiod	<numeric value>	
:WIDTh	<numeric value>	
:DCYCLE	<numeric value>	
:HOLD	WIDTh DCYCLE	
:DELay	<numeric value>	
:GATE		
:TYPE	ASync SYNC	
:LEVel	HIGH LOW	
STATUS:		
:OPERation		
:[EVENT]?		[query only, always returns "0"]
:CONDition?		[query only, always returns "0"]
:ENABle	<numeric value>	[implemented but not useful]
:QUEStionable		
:[EVENT]?		[query only, always returns "0"]
:CONDition?		[query only, always returns "0"]
:ENABle	<numeric value>	[implemented but not useful]
SYSTEM:		
:COMMunicate		
:GPIB		
:ADDReSS	<numeric value>	
:SERial		
:CONTRol		
:RTS	ON IBFull RFR	
:[RECeive]		
:BAUD	1200 2400 4800 9600 19200 38400 57600 115200	
:ERRor		

: [NEXT]?		[query only]
: COUNT?		[query only]
: VERsion?		[query only]
TRIGger:		
: SOURce	INTernal EXTernal MANual HOLD IMMEDIATE	
*CLS		[no query form]
*ESE	<numeric value>	
*ESR?		[query only]
*IDN?		[query only]
*OPC		
*SAV	0 1 2 3	[no query form]
*RCL	0 1 2 3	[no query form]
*RST		[no query form]
*SRE	<numeric value>	
*STB?		[query only]
*TST?		[query only]
*WAI		[no query form]

MECHANICAL INFORMATION

TOP COVER REMOVAL

If necessary, the interior of the instrument may be accessed by removing the four Phillips screws on the top panel. With the four screws removed, the top cover may be slid back (and off).

 Always disconnect the power cord and allow the instrument to sit unpowered for 10 minutes before opening the instrument. This will allow any internal stored charge to discharge.

There are no user-adjustable internal circuits. For repairs other than fuse replacement, please contact Avtech (info@avtechpulse.com) to arrange for the instrument to be returned to the factory for repair. Service is to be performed solely by qualified service personnel.

 Caution: High voltages are present inside the instrument during normal operation. Do not operate the instrument with the cover removed.

RACK MOUNTING

A rack mounting kit is available. The -R5 rack mount kit may be installed after first removing the one Phillips screw on the side panel adjacent to the front handle.

ELECTROMAGNETIC INTERFERENCE

To prevent electromagnetic interference with other equipment, all used outputs should be connected to shielded loads using shielded coaxial cables. Unused outputs should be terminated with shielded coaxial terminators or with shielded coaxial dust caps, to prevent unintentional electromagnetic radiation. All cords and cables should be less than 3m in length.

MAINTENANCE

REGULAR MAINTENANCE

This instrument does not require any regular maintenance.

On occasion, one or more of the four rear-panel fuses may require replacement. All fuses can be accessed from the rear panel. See the “FUSES” section for details.

CLEANING

If desired, the interior of the instrument may be cleaned using compressed air to dislodge any accumulated dust. (See the “TOP COVER REMOVAL” section for instructions on accessing the interior.) No other cleaning is recommended.

TRIGGER DAMAGE

The rear-panel TRIG input, used in the external trigger mode, is protected by a diode clamping circuit. However, the protection circuit is not foolproof, and it is possible for a grossly excessive signal to damage the trigger circuitry on the main timing control board (the 4×10 inch board on the right side of the instrument).

The IC that is most likely to fail under these conditions is installed in a socket. It is a standard TTL IC in a 16-pin plastic DIP package, model 74F151 or equivalent.

If you suspect that this IC has been damaged, turn off the power and replace this IC. It may be replaced by a 74F151, 74LS151, 74ALS151, or 74HCT151.

PCB 158R7 - LOW VOLTAGE POWER SUPPLY

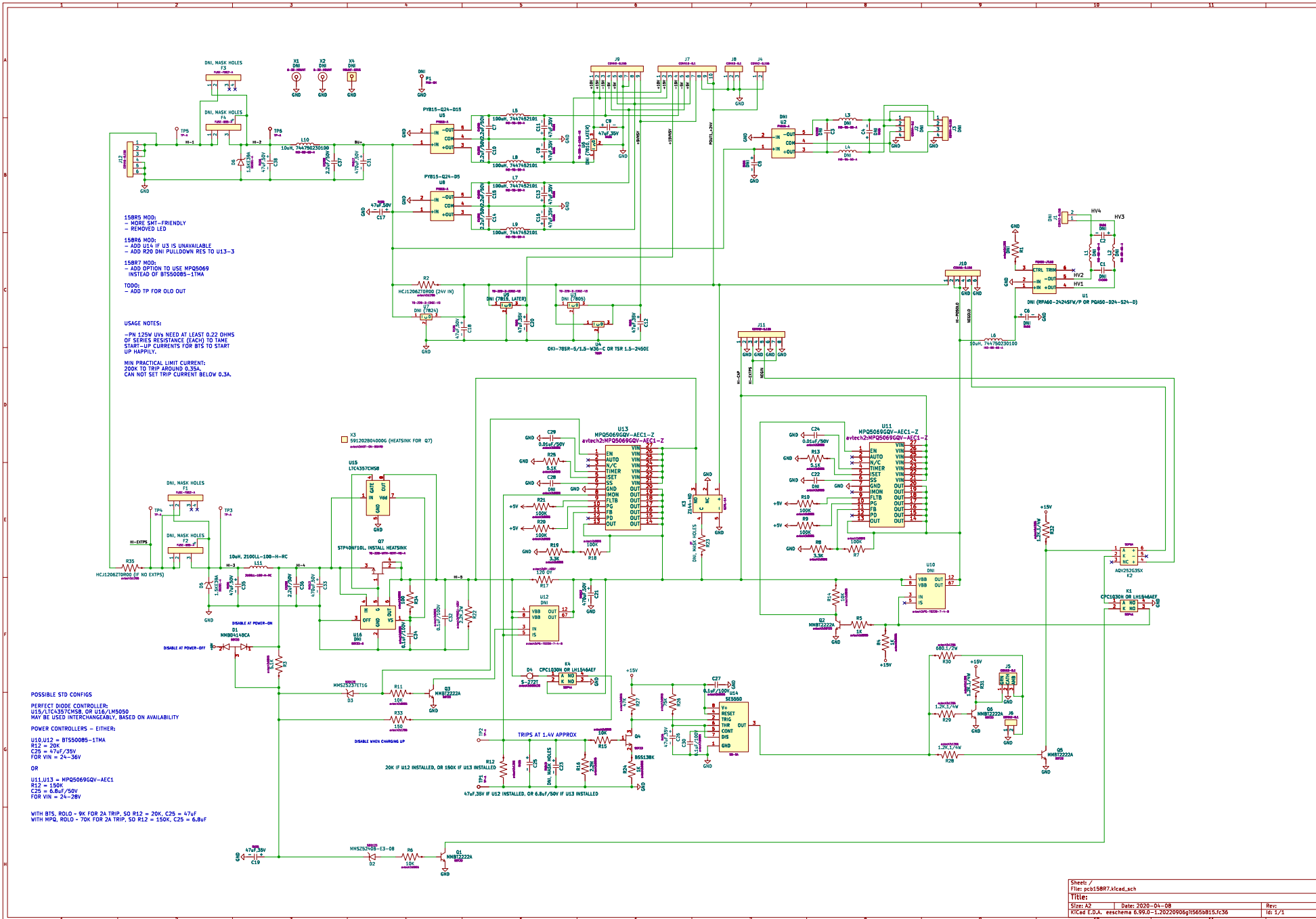

158RS MOD:
 - NONE SMT-FRIENDLY
 - REMOVED LED

158R6 MOD:
 - ADD U34 IF U3 IS UNAVAILABLE
 - ADD R20 DNI PULLDOWN RES TO U13-3

158R7 MOD:
 - ADD OPTION TO USE WP05069
 INSTEAD OF B15500B5-1TMA

TODO:
 - ADD TP FOR OLO OUT

USAGE NOTES:
 -PH 125W LVX NEED AT LEAST 0.22 OHMS
 OF SERIES RESISTANCE (EACH) TO TAME
 START-UP CURRENTS FOR B15 TO START
 UP HAPPILY.

MIN PRACTICAL LIMIT CURRENT:
 200K TO TRIP AROUND 0.35A
 CAN NOT SET TRIP CURRENT BELOW 0.3A.

POSSIBLE STD CONFIGS
 PERFECT DIODE CONTROLLER:
 U5/LTC437CMBR, OR U16/LM5050
 MAY BE USED INTERCHANGEABLY, BASED ON AVAILABILITY

POWER CONTROLLERS - EITHER:
 U10 U12 = B15500B5-1TMA
 R12 = 20K
 C25 = 47uF/35V
 FOR VIN = 24-36V

OR
 U11 U13 = NP05069GQV-ACE1
 R12 = 150K
 C25 = 6.8uF/50V
 FOR VIN = 24-28V

WITH B15, R0L0 - 9K FOR 2A TRIP, SO R12 = 20K, C25 = 47uF
 WITH MFC, R0L0 - 70K FOR 2A TRIP, SO R12 = 150K, C25 = 6.8uF

PCB 156D - POLARITY CONTROL PCB (-PN UNITS)

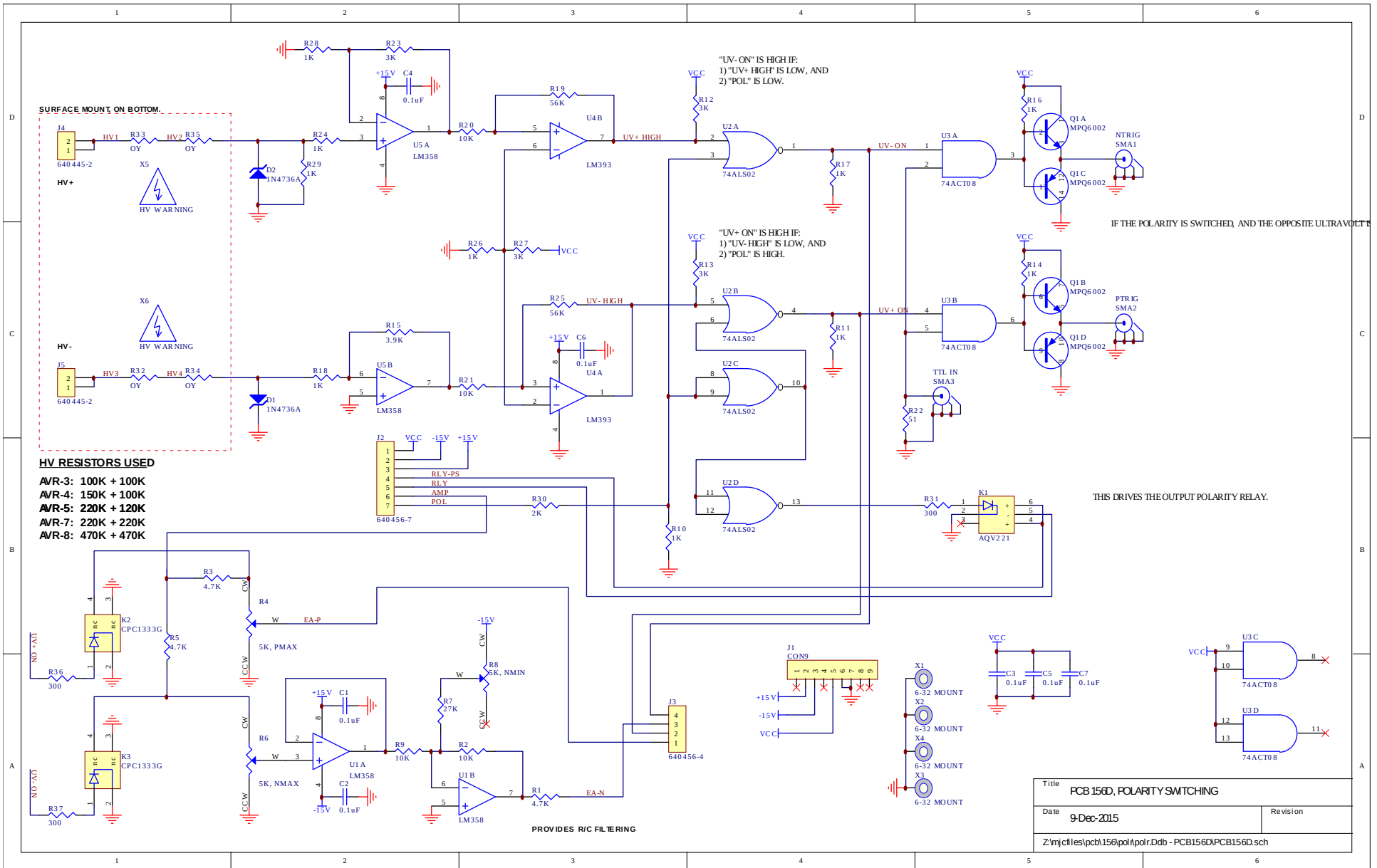

PCB 104H - KEYPAD / DISPLAY BOARD

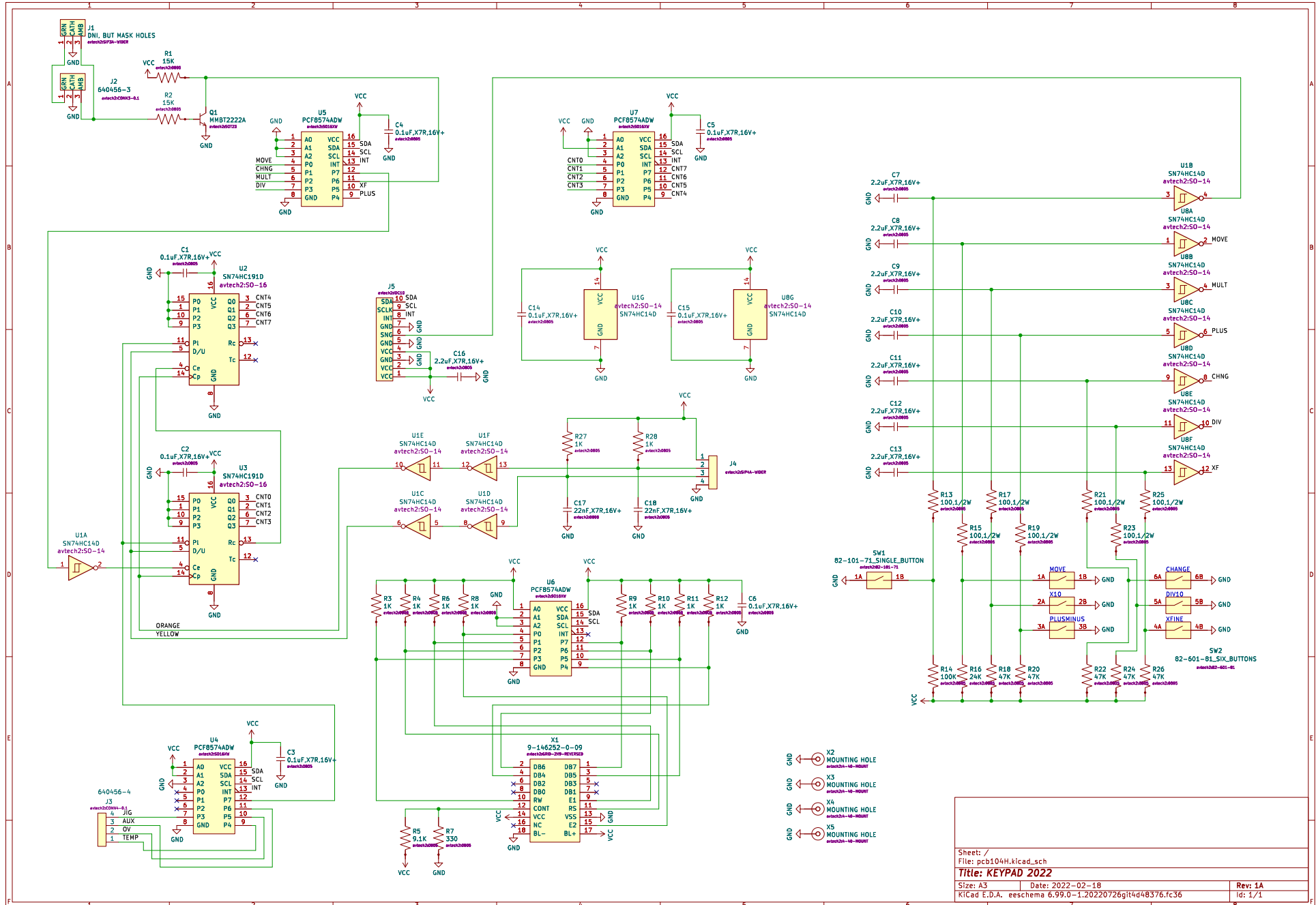

PERFORMANCE CHECK SHEET