



AVTECH ELECTROSYSTEMS LTD.

NANOSECOND WAVEFORM ELECTRONICS  
SINCE 1975

info@avtechpulse.com  
<http://www.avtechpulse.com/>

Tel: 888-670-8729 (USA & Canada)  
or +1-613-686-6675 (Worldwide)

BOX 5120, LCD MERIVALE  
OTTAWA, CANADA K2C3H5

## INSTRUCTIONS

MODEL AVR-8A-B

1000 V, 1 kHz PULSE GENERATOR

WITH IEEE 488.2 AND RS-232 CONTROL

SERIAL NUMBER: 14548

### WARRANTY

Avtech Electrosystems Ltd. warrants products of its manufacture to be free from defects in material and workmanship under conditions of normal use. If, within one year after delivery to the original owner, and after prepaid return by the original owner, this Avtech product is found to be defective, Avtech shall at its option repair or replace said defective item. This warranty does not apply to units which have been disassembled, modified or subjected to conditions exceeding the applicable specifications or ratings. This warranty is the extent of the obligation assumed by Avtech with respect to this product and no other warranty or guarantee is either expressed or implied.

### TECHNICAL SUPPORT

Phone: 888-670-8729 (USA & Canada)  
or +1-613-686-6675 (Worldwide)

E-mail: [info@avtechpulse.com](mailto:info@avtechpulse.com)  
World Wide Web: <http://www.avtechpulse.com>

## TABLE OF CONTENTS

|                                      |           |
|--------------------------------------|-----------|
| <b>WARRANTY.....</b>                 | <b>2</b>  |
| <b>TECHNICAL SUPPORT.....</b>        | <b>2</b>  |
| <b>TABLE OF CONTENTS.....</b>        | <b>3</b>  |
| <b>INTRODUCTION.....</b>             | <b>6</b>  |
| <b>AVAILABLE OPTIONS.....</b>        | <b>7</b>  |
| <b>HIGH-VOLTAGE PRECAUTIONS.....</b> | <b>8</b>  |
| <b>SPECIFICATIONS.....</b>           | <b>9</b>  |
| <b>REGULATORY NOTES.....</b>         | <b>11</b> |
| FCC PART 18.....                     | 11        |
| EC DECLARATION OF CONFORMITY.....    | 11        |
| DIRECTIVE 2011/65/EU (RoHS).....     | 12        |
| DIRECTIVE 2002/96/EC (WEEE).....     | 12        |
| FIRMWARE LICENSING.....              | 13        |
| <b>INSTALLATION.....</b>             | <b>14</b> |
| VISUAL CHECK.....                    | 14        |
| POWER RATINGS.....                   | 14        |
| CONNECTION TO THE POWER SUPPLY.....  | 14        |
| PROTECTION FROM ELECTRIC SHOCK.....  | 15        |
| ENVIRONMENTAL CONDITIONS.....        | 16        |
| LABVIEW DRIVERS.....                 | 16        |
| <b>FUSES.....</b>                    | <b>17</b> |
| AC FUSE REPLACEMENT.....             | 17        |
| DC FUSE REPLACEMENT.....             | 18        |
| FUSE RATINGS.....                    | 18        |
| <b>FRONT PANEL CONTROLS.....</b>     | <b>20</b> |
| <b>REAR PANEL CONTROLS.....</b>      | <b>22</b> |
| <b>GENERAL INFORMATION.....</b>      | <b>24</b> |
| BASIC PULSE CONTROL.....             | 24        |
| TRIGGER MODES.....                   | 26        |
| PULSE WIDTH MODES.....               | 26        |
| GATING MODES.....                    | 26        |
| PREVENTING OUTPUT STAGE FAILURE..... | 27        |
| -ADPT1 ADAPTER KIT.....              | 27        |

|  |           |
|--|-----------|
| <b>OUTPUT AND LOAD IMPEDANCE (STANDARD UNITS).....</b>                 | <b>28</b> |
| OUTPUT IMPEDANCE.....  | 28        |
| LOAD IMPEDANCE.....  | 28        |
| <b>OUTPUT AND LOAD IMPEDANCE (-R50 UNITS).....</b>                     | <b>29</b> |
| -R50 OPTION.....   | 29        |
| SAMPLE WAVEFORMS FOR VARIOUS ROUT / RLOAD VALUES.....                  | 29        |
| DRIVING A DIODE LOAD DIRECTLY.....                                     | 31        |
| <b>OPERATIONAL CHECK.....</b>  | <b>32</b> |
| <b>PROGRAMMING YOUR PULSE GENERATOR.....</b>                           | <b>35</b> |
| KEY PROGRAMMING COMMANDS.....  | 35        |
| ALL PROGRAMMING COMMANDS.....  | 36        |
| <b>MECHANICAL INFORMATION.....</b>                                     | <b>38</b> |
| TOP COVER REMOVAL.....   | 38        |
| RACK MOUNTING.....   | 38        |
| ELECTROMAGNETIC INTERFERENCE.....                                      | 38        |
| <b>MAINTENANCE.....</b>  | <b>39</b> |
| REGULAR MAINTENANCE.....   | 39        |
| CLEANING.....  | 39        |
| <b>WIRING DIAGRAMS.....</b>  | <b>40</b> |
| WIRING OF AC POWER (STANDARD UNITS).....                               | 40        |
| WIRING OF AC POWER (-XP2 UNITS).....                                   | 41        |
| WIRING OF DC POWER SUPPLIES.....                                       | 42        |
| PCB 158R7 - LOW VOLTAGE POWER SUPPLY (STANDARD UNITS).....             | 43        |
| PCB 158R5 - LOW VOLTAGE POWER SUPPLY (-XP2 UNITS).....                 | 44        |
| PCB 156E - POLARITY CONTROL PCB.....                                   | 45        |
| PCB 197L - HIGH-VOLTAGE POWER SUPPLY.....                              | 46        |
| PCB 183A-S AND 183A-P CAPACITOR BANKS.....                             | 47        |
| PCB 341A - INTERLOCK BOARD.....  | 48        |
| PCB 104H - KEYPAD / DISPLAY BOARD.....                                 | 49        |
| PCB 295G - MAIN CONTROL BOARD, 1 OF 13, TOP-LEVEL.....                 | 50        |
| PCB 295G - MAIN CONTROL BOARD, 2 OF 13, MICROCONTROLLER TOP-LEVEL..... | 51        |
| PCB 295G - MAIN CONTROL BOARD, 3 OF 13, EMBEDDED CONTROLLER.....       | 52        |
| PCB 295G - MAIN CONTROL BOARD, 4 OF 13, GPIB INTERFACE.....            | 53        |
| PCB 295G - MAIN CONTROL BOARD, 5 OF 13, DACs.....                      | 54        |
| PCB 295G - MAIN CONTROL BOARD, 6 OF 13, TIMING TOP-LEVEL.....          | 55        |

**PCB 295G - MAIN CONTROL BOARD, 7 OF 13, GATE CIRCUIT.....56**  
**PCB 295G - MAIN CONTROL BOARD, 8 OF 13, OSCILLATOR.....57**  
**PCB 295G - MAIN CONTROL BOARD, 9 OF 13, TTL OUTPUTS.....58**  
**PCB 295G - MAIN CONTROL BOARD, 10 OF 13, DELAY CIRCUITS.....59**  
**PCB 295G - MAIN CONTROL BOARD, 11 OF 13, PULSE WIDTH CIRCUIT.....60**  
**PCB 295G - MAIN CONTROL BOARD, 12 OF 13, TRIGGER SELECT.....61**  
**PCB 295G - MAIN CONTROL BOARD, 13 OF 13, SHIFT REGISTERS.....62**  
**MAIN WIRING..... 63**  
***PERFORMANCE CHECK SHEET..... 64***

Manual Reference: /files/officefiles/instructword/avr-8/AVR-8A-B,sn14548.odt.  
Last modified February 6, 2025.  
Copyright © 2025 Avtech Electrosystems Ltd, All Rights Reserved.

## INTRODUCTION

The AVR-8A-B is a high performance, GPIB and RS232-equipped instrument capable of generating up to 1000V at repetition rates up to 1 kHz into loads of 50 $\Omega$  or higher. The pulse width is variable from 200 ns to 200  $\mu$ s, and the duty cycle may be as high as 0.2% (or 0.5% with the -XP1 option, or 1% with the -XP2 option). Rise and fall times are fixed at less than 50 ns (or 60 ns for units with the -R50 option). The AVR-8A-B includes an internal trigger source, but it can also be triggered or gated by an external source. A front-panel pushbutton can also be used to trigger the instrument. The output pulse width can be set to follow an input trigger pulse width.

The output voltage polarity depends on the model number:

- "-P" units: up to +1000 Volts
- "-N" units: up to -1000 Volts
- "-PN" units: up to  $\pm$ 1000 Volts

The AVR-8A-B features front panel keyboard and adjust knob control of the output pulse parameters along with a four line by 40-character backlit LCD display of the output amplitude, pulse width, pulse repetition frequency, and delay. The instrument includes memory to store up to four complete instrument setups. The operator may use the front panel or the computer interface to store a complete "snapshot" of all key instrument settings, and recall this setup at a later time.

The instrument is protected against overload conditions (such as short circuits) by an automatic control circuit. An internal power supply monitor removes the power to the output stage for five seconds if an average power overload exists. After that time, the unit operates normally for one second, and if the overload condition persists, the power is cut again. This cycle repeats until the overload is removed.

This instrument is intended for use in research, development, test and calibration laboratories by qualified personnel.

### AVAILABLE OPTIONS

- ADPT1 Option: Adapter kit, consisting of an SHV PLUG to MHV FEMALE adapter and an MHV MALE to BNC FEMALE adapter.
- NC Option: The standard SHV-type output connector is replaced with an N-type connector.
- HN Option: The standard SHV-type output connector is replaced with an HN-type connector.
- MHV Option: The standard SHV-type output connector is replaced with an MHV-type connector.
- PW100 Option: Reduces the minimum pulse width from 200 ns to 100 ns.
- QD Option: Provides faster amplitude control discharge times.
- R5 Option: Rack-mount kit.
- R50 Option: Switchable output impedance. This allows the output impedance to be switched between the standard value of  $0\Omega$  (nominally) or  $50\Omega$  (for back-matching purposes).
- XP1 Option: Boosts the maximum duty cycle to 0.5%.
- XP2 Option: Boosts the maximum duty cycle to 1%.

## HIGH-VOLTAGE PRECAUTIONS

 **CAUTION:** This instrument provides output voltages as high as 1000 Volts under normal operating conditions, and generates up to 1070V internally, so extreme caution must be employed when using this instrument. The instrument should only be used by individuals who are thoroughly skilled in high voltage laboratory techniques. The following precautions should always be observed:

1. Keep exposed high-voltage wiring to an absolute minimum.
2. Wherever possible, use shielded connectors and cabling.
3. Connect and disconnect loads and cables only when the instrument is turned off.
4. Keep in mind that all cables, connectors, oscilloscope probes, and loads must have an appropriate voltage rating.

Do not attempt any repairs on the instrument, beyond the fuse replacement procedures described in this manual. Contact Avtech technical support (see page 2 for contact information) if the instrument requires servicing.



## SPECIFICATIONS

|   |  |
|---|--|
| Model <sup>1</sup> :  | AVR-8A-B   |
| Amplitude ( $V_{OUT}$ ) <sup>2,13</sup> :   | < 25 to 1000 Volts   |
| Maximum output current:   | 20 Amps  |
| Output resistance (in series with output):  | Standard: Nominally zero (< 2 $\Omega$ )<br>Optional <sup>14</sup> : Nominally zero (< 2 $\Omega$ ), or 50 $\Omega$ , switchable   |
| Rise & fall times (20%-80%) into $R_{LOAD} = 50\Omega$ :  | $\leq 50$ ns <sup>14</sup>   |
| Pulse width (FWHM) <sup>3</sup> :   | 200 ns to 200 $\mu$ s  |
| PRF: external trigger mode:<br>internal trigger:  | 0 to 1 kHz<br>1 Hz to 1 kHz  |
| Maximum duty cycle ( $DC_{MAX}$ ), and maximum average output power ( $P_{MAX}$ ) <sup>16</sup> : | $DC_{MAX}, P_{MAX}$<br>Standard: 0.2%, 40W<br>-XP1 option: 0.5%, 100W<br>-XP2 option: 1.0%, 200W   |
| Maximum droop at maximum pulse width, into 50 $\Omega$ <sup>12</sup> :                            | 6%   |
| Amplitude discharge time constant, $\tau_{DIS}$ (typical) <sup>9</sup> :                          | Standard: 30 sec<br>With -QD option: 1 sec   |
| Minimum time between full discharges of the HV PS <sup>10</sup> :                                 | Standard: > 5 $\tau_{DIS}$<br>With -QD option: 10 seconds  |
| Amplitude charge-up time <sup>11</sup> :  | < 8 seconds  |
| Polarity <sup>4</sup> :   | Positive or negative or both (specify -P, -N, or -PN).<br>Dual polarity not available with -XP2 option.  |
| GPIB and RS-232 control:  | Standard on -B units. See <a href="http://www.avtechpulse.com/gpib">http://www.avtechpulse.com/gpib</a> for more information.  |
| LabView Drivers:  | Available at <a href="http://www.avtechpulse.com/labview">http://www.avtechpulse.com/labview</a> .   |
| Ethernet port, for remote control using VXI-11.3, ssh, telnet, web:                               | Included. Recommended as a modern alternative to GPIB / RS-232.<br>See <a href="http://www.avtechpulse.com/options/vxi">http://www.avtechpulse.com/options/vxi</a> for details.  |
| Settings resolution:  | The resolution of the timing parameters (pulse width, delay, period) varies, but is always better than 0.15% of ( set value  + 20 ns). The amplitude resolution is < 0.1% of the maximum amplitude.  |
| Settings accuracy (into 50 $\Omega$ ):  | Typically $\pm 3\%$ (plus $\pm 1V$ or $\pm 2$ ns) after 10 minute warmup. For high-accuracy applications requiring traceable calibration, verify the output parameters with a calibrated oscilloscope <sup>15</sup> .  |
| Propagation delay:  | $\leq 200$ ns (Ext trig in to pulse out)   |
| Jitter (Ext trig in to pulse out):  | $\pm 100$ ps $\pm 0.03\%$ of sync delay  |
| Trigger modes:  | Internal trigger, external trigger (TTL level pulse, > 10 ns, 1 k $\Omega$ input impedance), front-panel "Single Pulse" pushbutton, or single pulse trigger via computer command. In the external trigger mode, the pulse width may be set by the instrument, or it may be set to track the input pulse width. |
| Variable delay:   | Sync to main out: 0 to 1.0 seconds, for all trigger modes (including external trigger).  |
| Sync output:  | > +3 Volts, > 50 ns, will drive 50 Ohm loads   |
| Gated operation:  | Synchronous or asynchronous, active high or low, switchable. Suppresses triggering when active.  |
| Connectors:   | OUT: SHV <sup>7,8</sup> . Trig, Sync, Gate: BNC  |
| Power requirements:   | 100 - 240 Volts, 50 - 60 Hz  |
| Dimensions (H x W x D):   | 100 mm x 430 mm x 375 mm (3.9" x 17" x 14.8")  |
| Chassis material:   | cast aluminum frame and handles, blue vinyl on aluminum cover plates   |
| Temperature range:  | +5°C to +40°C  |

1) -B suffix indicates GPIB-equipped model.

2) For operation at amplitudes of less than 10% of full-scale, best results will be obtained by setting the amplitude near full-scale and using external attenuators on the output.

3) The output pulse width may also be controlled externally by applying a TTL-level trigger of the desired width to a rear-panel BNC connector ( $PW_{IN} = PW_{OUT}$  mode).

4) Indicate desired polarity by suffixing the model number with -P or -N (i.e. positive or negative) or -PN for dual polarity option.

5) SHV, MHV or HN output connectors can also be provided. To specify, suffix the model number with -SHV, -MHV or -HN as required.

6) An N-male to BNC-female adapter (Amphenol P/N 31-216) is available. Add the suffix -ADPT2 to the model number to order this adapter.

7) An adapter kit, consisting of an SHV PLUG to MHV FEMALE adapter and an MHV MALE to BNC FEMALE adapter, is available. Add the suffix -ADPT1 to the model number to order this kit.

8) MHV, N or HN output connectors can also be provided. To specify, suffix the model number with -MHV, -NC or -HN as required.

9) The output amplitude is controlled by internal high-voltage DC power supplies. When the amplitude setting is reduced, the high voltage decays in an exponential fashion, with the typical time constant noted in this specification. The -QD option provides a fast active-discharge circuit.

10) More frequent discharges will cause the instrument to overheat, and may cause damage.

- 11) The output amplitude is controlled by internal high-voltage DC power supplies. This is the time required for the power supplies to rise from 5% to 95% of their full value in response to a change in settings from zero to the maximum setting.
- 12) Valid for 50 Ohm loads. The droop will be proportionally higher into lower resistance loads.
- 13) The instrument may be used to drive resistive loads of less than 50 Ohms, as long as the maximum output current specification is not exceeded. The rise and fall times may increase.
- 14) Add the suffix -R50 to specify the switchable 0/50Ω output resistance feature. The -R50 option will increase the specified rise and fall times by 10 ns. Not available with the -XP1 or -XP2 options. This option is useful for applications where a proper 50Ω termination at the load is impossible (for example, testing semiconductors in cryostats), because it provides 50Ω “back-matching” at the pulser end of the transmission line (absorbing reflections from the mismatched load).
- 15) These instruments are provided with a basic calibration checksheet, showing a selection of measured output parameters. These measurements are performed with equipment that is calibrated on a regular basis by a third-party ISO/IEC 17025:2005 accredited calibration laboratory. However, Avtech itself does not claim any accreditation. For applications requiring traceable performance, use a calibrated measurement system rather than relying on the accuracy of the pulse generator settings.
- 16) The maximum average output power is only obtainable at maximum amplitude.

## REGULATORY NOTES

### FCC PART 18

This device complies with part 18 of the FCC rules for non-consumer industrial, scientific and medical (ISM) equipment.

This instrument is enclosed in a rugged metal chassis and uses a filtered power entry module (where applicable). The main output signal is provided on a shielded connector that is intended to be used with shielded coaxial cabling and a shielded load. Under these conditions, the interference potential of this instrument is low.

If interference is observed, check that appropriate well-shielded cabling is used on the output connectors. Contact Avtech ([info@avtechpulse.com](mailto:info@avtechpulse.com)) for advice if you are unsure of the most appropriate cabling. Also, check that your load is adequately shielded. It may be necessary to enclose the load in a metal enclosure.

If any of the connectors on the instrument are unused, they should be covered with shielded metal “dust caps” to reduce the interference potential.

This instrument does not normally require regular maintenance to minimize interference potential. However, if loose hardware or connectors are noted, they should be tightened. Contact Avtech ([info@avtechpulse.com](mailto:info@avtechpulse.com)) if you require assistance.

### EC DECLARATION OF CONFORMITY



We                      Avtech Electrosystems Ltd.  
                             P.O. Box 5120, LCD Merivale  
                             Ottawa, Ontario  
                             Canada K2C 3H5

declare that this pulse generator meets the intent of Directive 2014/30/EU for Electromagnetic Compatibility. Compliance pertains to the following specifications as listed in the official Journal of the European Communities:

EN 50081-1 Emission

EN 50082-1 Immunity

and that this pulse generator meets the intent of the Low Voltage Directive 2014/35/EU. Compliance pertains to the following specifications as listed in the official Journal of the European Communities:

EN 61010-1:2010+A1:2019, Safety requirements for electrical equipment for measurement, control, and laboratory use

DIRECTIVE 2011/65/EU (RoHS)

We Avtech Electrosystems Ltd.  
P.O. Box 5120, LCD Merivale  
Ottawa, Ontario  
Canada K2C 3H5

declare that, to the best of our knowledge, all electrical and electronic equipment (EEE) sold by the company are in compliance with Directive 2011/65/EU of the European Parliament and of the Council of 8 June 2011 on the restriction of the use of certain hazardous substances in electrical and electronic equipment (also known as “RoHS Recast”). In addition, this declaration of conformity is issued under the sole responsibility of Avtech Electrosystems Ltd. Specifically, products manufactured do not contain the substances listed in the table below in concentrations greater than the listed maximum value.

| <i>Material/Substance</i>             | <i>Threshold level</i>    |
|---------------------------------------|---------------------------|
| Lead (Pb)                             | < 1000 ppm (0.1% by mass) |
| Mercury (Hg)                          | < 1000 ppm (0.1% by mass) |
| Hexavalent Chromium (Cr6+)            | < 1000 ppm (0.1% by mass) |
| Polybrominated Biphenyls (PBB)        | < 1000 ppm (0.1% by mass) |
| Polybrominated Diphenyl ethers (PBDE) | < 1000 ppm (0.1% by mass) |
| Cadmium (Cd)                          | < 100 ppm (0.01% by mass) |
| Bis(2-ethylhexyl) phthalate (DEHP)    | < 1000 ppm (0.1% by mass) |
| Butyl benzyl phthalate (BBP)          | < 1000 ppm (0.1% by mass) |
| Dibutyl phthalate (DBP)               | < 1000 ppm (0.1% by mass) |
| Diisobutyl phthalate (DIBP)           | < 1000 ppm (0.1% by mass) |

DIRECTIVE 2002/96/EC (WEEE)

European customers who have purchased this equipment directly from Avtech will have completed a “WEEE Responsibility Agreement” form, accepting responsibility for WEEE

compliance (as mandated in Directive 2002/96/EC of the European Union and local laws) on behalf of the customer, as provided for under Article 9 of Directive 2002/96/EC.

Customers who have purchased Avtech equipment through local representatives should consult with the representative to determine who has responsibility for WEEE compliance. Normally, such responsibilities will lie with the representative, unless other arrangements (under Article 9) have been made.

Requirements for WEEE compliance may include registration of products with local governments, reporting of recycling activities to local governments, and financing of recycling activities.

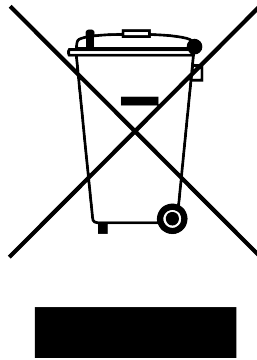

## FIRMWARE LICENSING

This instrument uses open-source software internally, and is built on a Fedora Linux operating system.

Some of this software requires that the source code be made available to the user as a condition of its licensing. The source code for programs used by Fedora is freely available at <https://src.fedoraproject.org/>.

The source code for modifications implemented by Avtech, and for Avtech-specific programs, is available at <https://www.avtechpulse.com/cgit/Instrument.git/>.

## INSTALLATION

### VISUAL CHECK

After unpacking the instrument, examine to ensure that it has not been damaged in shipment. Visually inspect all connectors, knobs, liquid crystal displays (LCDs), and the handles. Confirm that a power cord, a GPIB cable, and two instrumentation manuals (this manual and the “Programming Manual for -B Instruments”) are with the instrument. If the instrument has been damaged, file a claim immediately with the company that transported the instrument.

### POWER RATINGS

This instrument is intended to operate from 100 - 240 V, 50 - 60 Hz.

The maximum power consumption is 125 Watts (360 Watts for units with the -XP2 option). Please see the “FUSES” section for information about the appropriate AC and DC fuses.

This instrument is an “Installation Category II” instrument, intended for operation from a normal single-phase supply.

### CONNECTION TO THE POWER SUPPLY

An IEC-320 three-pronged recessed male socket is provided on the back panel for AC power connection to the instrument. One end of the detachable power cord that is supplied with the instrument plugs into this socket. The other end of the detachable power cord plugs into the local mains supply. Use only the cable supplied with the instrument. The mains supply must be earthed, and the cord used to connect the instrument to the mains supply must provide an earth connection. (The supplied cord does this.)

 Warning: Failure to use a grounded outlet may result in injury or death due to electric shock. This product uses a power cord with a ground connection. It must be connected to a properly grounded outlet. The instrument chassis is connected to the ground wire in the power cord.

The table below describes the power cord that is normally supplied with this instrument, depending on the destination region:

| Destination Region                             | Description                           | Option | Manufacturer | Part Number |
|--|---------------------------------------|--------|--------------|-------------|
| United Kingdom, Hong Kong, Singapore, Malaysia | BS 1363, 230V, 50 Hz                  | -AC00  | Qualtek      | 370001-E01  |
| Australia, New Zealand                         | AS 3112:2000, 230-240V, 50 Hz         | -AC01  | Qualtek      | 374003-A01  |
| Continental Europe, Korea, Indonesia, Russia   | European CEE 7/7 "Schuko" 230V, 50 Hz | -AC02  | Qualtek      | 364002-D01  |
| North America, Taiwan                          | NEMA 5-15, 120V, 60 Hz                | -AC03  | Qualtek      | 312007-01   |
| Switzerland                                    | SEV 1011, 230V, 50 Hz                 | -AC06  | Qualtek      | 378001-E01  |
| South Africa, India                            | SABS 164-1, 220-250V, 50 Hz           | -AC17  | Volex        | 2131H 10 C3 |
| Japan  | JIS 8303, 100V, 50-60 Hz              | -AC18  | Qualtek      | 397002-01   |
| Israel   | SI 32, 220V, 50 Hz                    | -AC19  | Qualtek      | 398001-01   |
| China  | GB 1002-1 / 2099-1, 220V, 50 Hz       | -AC22  | Qualtek      | 399012-01   |

## PROTECTION FROM ELECTRIC SHOCK

 Operators of this instrument must be protected from electric shock at all times. The owner must ensure that operators are prevented access and/or are insulated from every connection point. In some cases, connections must be exposed to potential human contact. Operators must be trained to protect themselves from the risk of electric shock. This instrument is intended for use by qualified personnel who recognize shock hazards and are familiar with safety precautions required to avoid possibly injury. In particular, operators should:

1. Keep exposed high-voltage wiring to an absolute minimum.
2. Wherever possible, use shielded connectors and cabling.
3. Connect and disconnect loads and cables only when the instrument is turned off.
4. Keep in mind that all cables, connectors, oscilloscope probes, and loads must have an appropriate voltage rating.
5. Do not attempt any repairs on the instrument, beyond the fuse replacement procedures described in this manual. Contact Avtech technical support (see page 2 for contact information) if the instrument requires servicing. Service is to be performed solely by qualified service personnel.

## ENVIRONMENTAL CONDITIONS

This instrument is intended for use under the following conditions:

1. indoor use;
2. altitude up to 2 000 m;
3. temperature 5 °C to 40 °C;
4. maximum relative humidity 80 % for temperatures up to 31 °C decreasing linearly to 50 % relative humidity at 40 °C;
5. Mains supply voltage fluctuations up to  $\pm 10$  % of the nominal voltage;
6. no pollution or only dry, non-conductive pollution.

## LABVIEW DRIVERS

A LabVIEW driver for this instrument is available for download on the Avtech web site, at <http://www.avtechpulse.com/labview>. A copy is also available in National Instruments' Instrument Driver Library at <http://www.natinst.com/>.



## FUSES

This instrument contains four fuses. All are accessible from the rear-panel. Two protect the AC prime power input, and two protect the internal DC power supplies. The locations of the fuses on the rear panel are shown in the figure below:

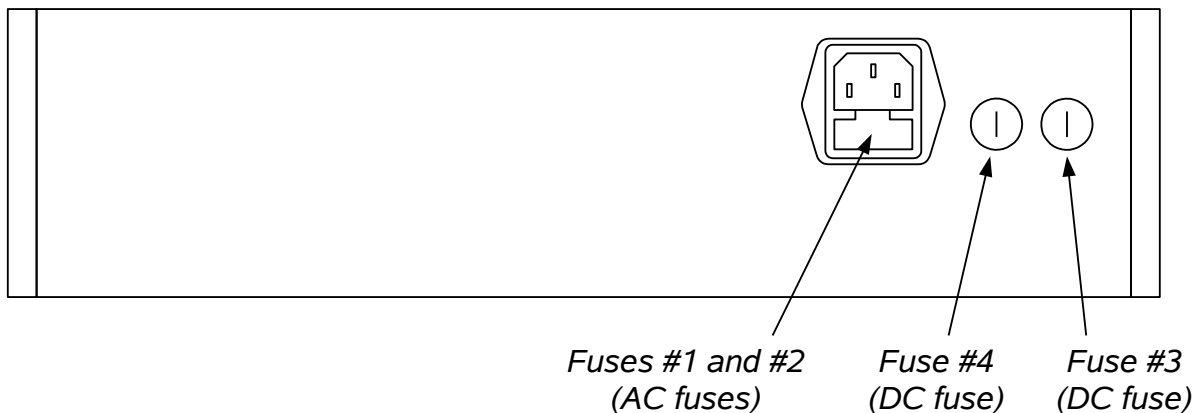

### AC FUSE REPLACEMENT

To physically access the AC fuses, the power cord must be detached from the rear panel of the instrument. The fuse drawer may then be extracted using a small flat-head screwdriver, as shown below:

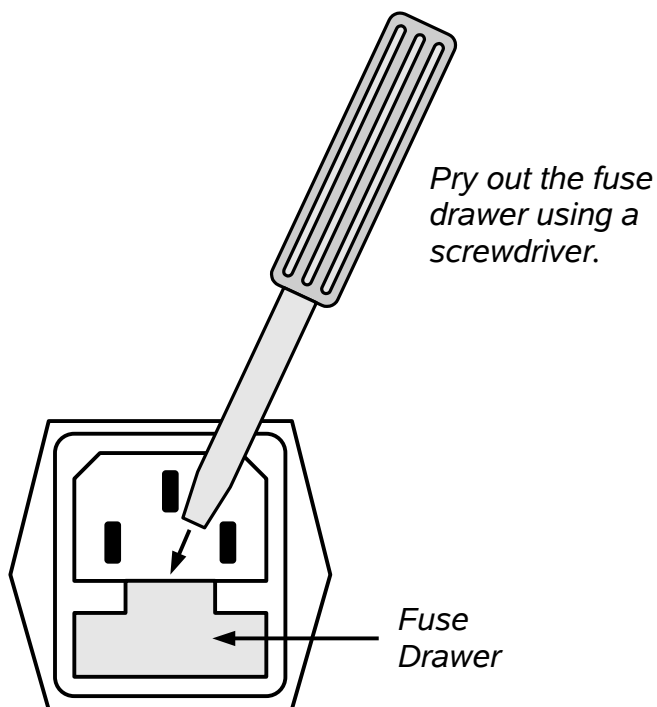

## DC FUSE REPLACEMENT

The DC fuses may be replaced by inserting the tip of a flat-head screwdriver into the fuse holder slot, and rotating the slot counter-clockwise. The fuse and its carrier will then pop out.

## FUSE RATINGS

The following table lists the required fuses for -P models without the -XP1 or -XP2 options:

| Fuses          | Nominal Mains Voltage | Rating                    | Case Size | Recommended Replacement Part |                       |
|----------------|-----------------------|---------------------------|-----------|------------------------------|-----------------------|
|                |                       |                           |           | Littelfuse Part Number       | Digi-Key Stock Number |
| #1, #2<br>(AC) | 115 V                 | 1.6A, 250V,<br>Time-Delay | 5×20 mm   | 021801.6HXP                  | F2424-ND              |
|                | 230 V                 | 0.8A, 250V,<br>Time-Delay | 5×20 mm   | 0218.800HXP                  | F2418-ND              |
| #3<br>(DC)     | N/A                   | 1.6A, 250V,<br>Time-Delay | 5×20 mm   | 021801.6HXP                  | F2424-ND              |
| #4<br>(DC)     | N/A                   | 4.0A, 250V,<br>Time-Delay | 5×20 mm   | 0218004.HXP                  | F2421-ND              |

The following table lists the required fuses for -N models without the -XP1 or -XP2 options:

| Fuses          | Nominal Mains Voltage | Rating                    | Case Size | Recommended Replacement Part |                       |
|----------------|-----------------------|---------------------------|-----------|------------------------------|-----------------------|
|                |                       |                           |           | Littelfuse Part Number       | Digi-Key Stock Number |
| #1, #2<br>(AC) | 115 V                 | 1.6A, 250V,<br>Time-Delay | 5×20 mm   | 021801.6HXP                  | F2424-ND              |
|                | 230 V                 | 0.8A, 250V,<br>Time-Delay | 5×20 mm   | 0218.800HXP                  | F2418-ND              |
| #3<br>(DC)     | N/A                   | 1.6A, 250V,<br>Time-Delay | 5×20 mm   | 021801.6HXP                  | F2424-ND              |
| #4<br>(DC)     | N/A                   | 5.0A, 250V,<br>Time-Delay | 5×20 mm   | 0218005.HXP                  | F2422-ND              |

Units with the -XP2 option have different fuse requirements:

| Fuses          | Nominal Mains Voltage | Rating                     | Case Size | Recommended Replacement Part |                       |
|----------------|-----------------------|----------------------------|-----------|------------------------------|-----------------------|
|                |                       |                            |           | Littelfuse Part Number       | Digi-Key Stock Number |
| #1, #2<br>(AC) | 115 V                 | 3.15A, 250V,<br>Time-Delay | 5×20 mm   | 02183.15HXP                  | F2430-ND              |
|                | 230 V                 | 1.6A, 250V,<br>Time-Delay  | 5×20 mm   | 021801.6HXP                  | F2424-ND              |
| #3<br>(DC)     | N/A                   | 1.0A, 250V,<br>Time-Delay  | 5×20 mm   | 0218001.HXP                  | F2419-ND              |
| #4<br>(DC)     | N/A                   | 10A, 250V,<br>Time-Delay   | 5×20 mm   | 0218010.HXP                  | F2425-ND              |

The recommended fuse manufacturer is Littelfuse (<http://www.littelfuse.com>).

Replacement fuses may be easily obtained from Digi-Key (<http://www.digikey.com>) and other distributors.

## FRONT PANEL CONTROLS

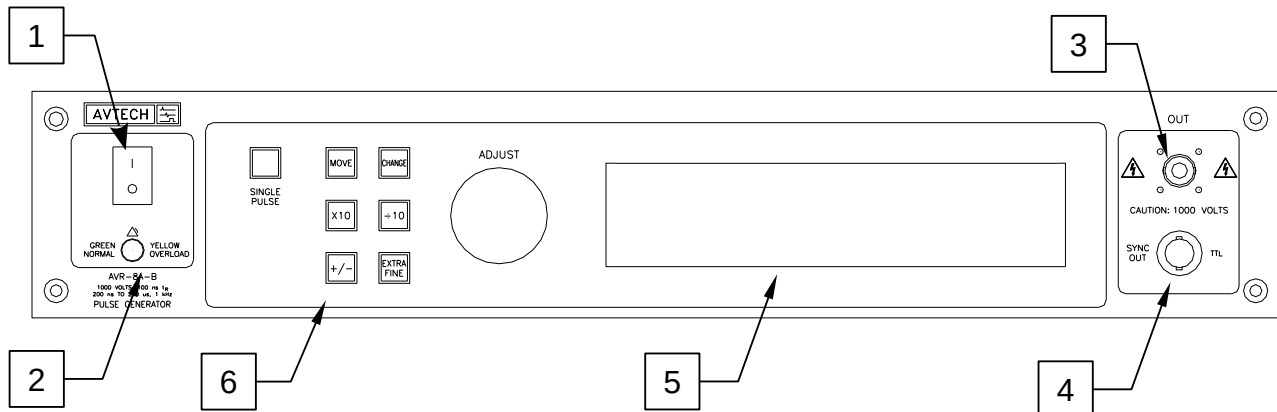

1. **POWER Switch**. This is the main power switch. When turning the instrument on, there is normally a delay of 10 seconds before anything is shown on the main display, as the internal operating system boots up.
2. **OVERLOAD Indicator**. When the instrument is powered, this indicator is normally green, indicating normal operation. If this indicator is yellow, an internal automatic overload protection circuit has been tripped. If the unit is overloaded (by operating at an exceedingly high duty cycle or by operating into a very low impedance), the protective circuit will disable the output of the instrument and turn the indicator light yellow. The light will stay yellow (i.e. output disabled) for about 5 seconds after which the instrument will attempt to re-enable the output (i.e. light green) for about 1 second. If the overload condition persists, the output will be disabled again (i.e. light yellow) for another 5 seconds. If the overload condition has been removed, the instrument will resume normal operation.

This overload indicator may flash yellow briefly at start-up. This is not a cause for concern.

3. **OUT CONNECTOR**. This SHV-type connector (or optionally N, HN, or MHV-type connector) provides the output to a 50Ω (or higher) load.

 **Caution:** Voltages as high as  $\pm 1000\text{V}$  may be present on the center conductor of this output connector. Avoid touching this conductor. Connect to this connector using standard coaxial cable, to ensure that the center conductor is not exposed.

4. **SYNC OUT**. This connector supplies a SYNC output that can be used to trigger other equipment, particularly oscilloscopes. This signal leads (or lags) the main output by a duration set by the "DELAY" controls and has an approximate amplitude of +3 Volts to  $R_L > 1\text{k}\Omega$  with a pulse width of approximately 100 ns.
5. **LIQUID CRYSTAL DISPLAY (LCD)**. This LCD is used in conjunction with the keypad to change the instrument settings. Normally, the main menu is displayed, which lists

the key adjustable parameters and their current values. The “Programming Manual for -B Instruments” describes the menus and submenus in detail.

## 6. KEYPAD.

| Control Name | Function  |
|--------------|---|
| MOVE         | This moves the arrow pointer on the display.  |
| CHANGE       | This is used to enter the submenu, or to select the operating mode, pointed to by the arrow pointer.  |
| ×10          | If one of the adjustable numeric parameters is displayed, this increases the setting by a factor of ten.  |
| ÷10          | If one of the adjustable numeric parameters is displayed, this decreases the setting by a factor of ten.  |
| +/-          | If one of the adjustable numeric parameters is displayed, and this parameter can be both positive or negative, this changes the sign of the parameter.  |
| EXTRA FINE   | This changes the step size of the ADJUST knob. In the extra-fine mode, the step size is twenty times finer than in the normal mode. This button switches between the two step sizes.  |
| ADJUST       | This large knob adjusts the value of any displayed numeric adjustable values, such as frequency, pulse width, etc. The adjust step size is set by the "EXTRA FINE" button.<br><br>When the main menu is displayed, this knob can be used to move the arrow pointer. |

## REAR PANEL CONTROLS

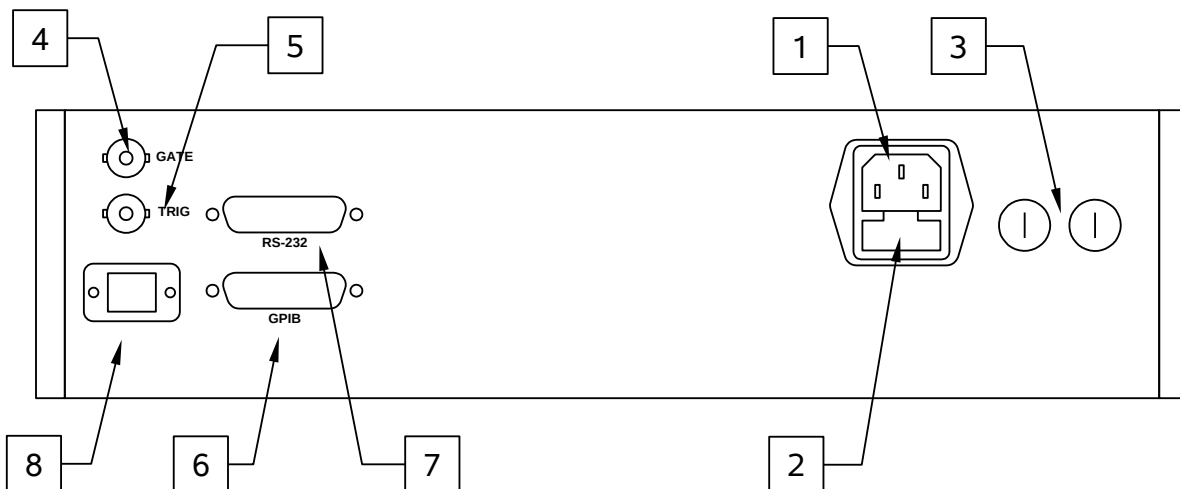

*Note: some connectors may be in different positions than shown above, depending on the exact combination of options ordered.*

1. AC POWER INPUT. An IEC-320 C14 three-pronged recessed male socket is provided on the back panel for AC power connection to the instrument. One end of the detachable power cord that is supplied with the instrument plugs into this socket.
2. AC FUSE DRAWER. The two fuses that protect the AC input are located in this drawer. Please see the “FUSES” section of this manual for more information.
3. DC FUSES. These two fuses protect the internal DC power supplies. Please see the “FUSES” sections of this manual for more information.
4. GATE. This TTL-level (0 and +5V) logic input can be used to gate the triggering of the instrument. This input can be either active high or active low, depending on the front panel settings or programming commands. (The instrument triggers normally when this input is unconnected). When set to active high mode, this input is pulled-down to ground by a 1 k $\Omega$  resistor. When set to active low mode, this input is pulled-up to +5V by a 1 k $\Omega$  resistor.
5. TRIG. This TTL-level (0 and +5V) logic input can be used to trigger the instrument, if the instrument is set to triggering externally. The instrument triggers on the rising edge of this input. The input impedance of this input is 1 k $\Omega$ . (Depending on the length of cable attached to this input, and the source driving it, it may be desirable to add a coaxial 50 Ohm terminator to this input to provide a proper transmission line termination. The Pasternack ([www.pasternack.com](http://www.pasternack.com)) PE6008-50 BNC feed-thru 50 Ohm terminator is suggested for this purpose.)

When triggering externally, the instrument can be set such that the output pulse width tracks the pulse width on this input, or the output pulse width can be set independently.

6. GPIB Connector. A standard GPIB cable can be attached to this connector to allow the instrument to be computer-controlled. See the “Programming Manual for -B Instruments” for more details on GPIB control.
7. RS-232 Connector. A standard serial cable with a 25-pin male connector can be attached to this connector to allow the instrument to be computer-controlled. A user name (“admin”) and a password (“default”, as shipped from the factory) are required when logging into a serial terminal session. The internal controller attempts to auto-sense the parity setting. It may be necessary to send a few return characters before attempting a login in order to provide enough data to allow this auto-sensing to work. (A standard Linux “agetty” process is used to implement serial control internally.) See the “Programming Manual for -B Instruments” for more details on RS-232 control.
8. Network Connector. This Ethernet connector allows the instrument to be remotely controlled using the VXI-11.3, ssh (secure shell), telnet, and http (web) protocols. See the “Programming Manual for -B Instruments” for more details.

## GENERAL INFORMATION

### BASIC PULSE CONTROL

This instrument can be triggered by its own internal clock or by an external TTL trigger signal. In either case, two output channels respond to the trigger: OUT and SYNC. The OUT channel is the signal that is applied to the load. Its amplitude and pulse width are variable. The SYNC pulse is a fixed-width TTL-level reference pulse used to trigger oscilloscopes or other measurement systems. When the delay is set to a positive value the SYNC pulse precedes the OUT pulse. When the delay is set to a negative value the SYNC pulse follows the OUT pulse.

These pulses are illustrated below, assuming internal triggering and a positive delay:

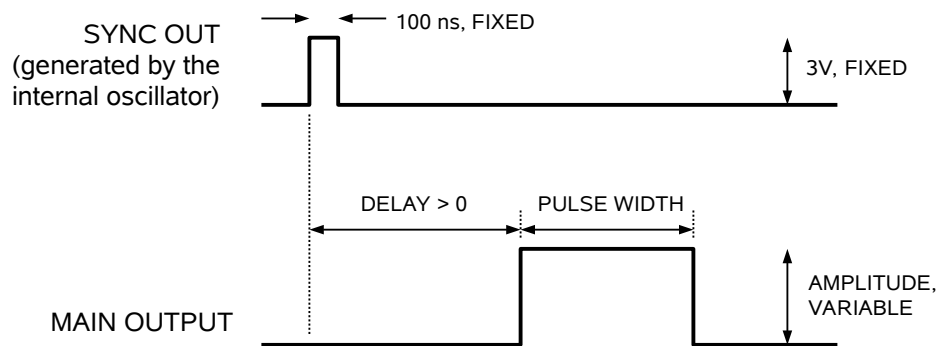

*Figure A*

If the delay is negative, the order of the SYNC and OUT pulses is reversed:

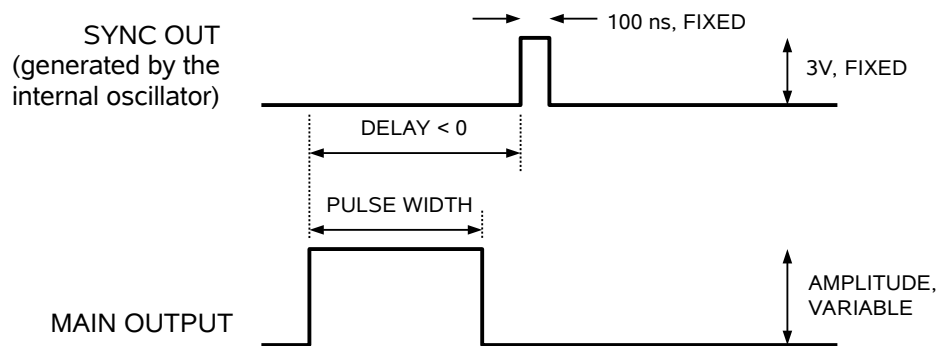

*Figure B*

The next figure illustrates the relationship between the signal when an external TTL-level trigger is used:



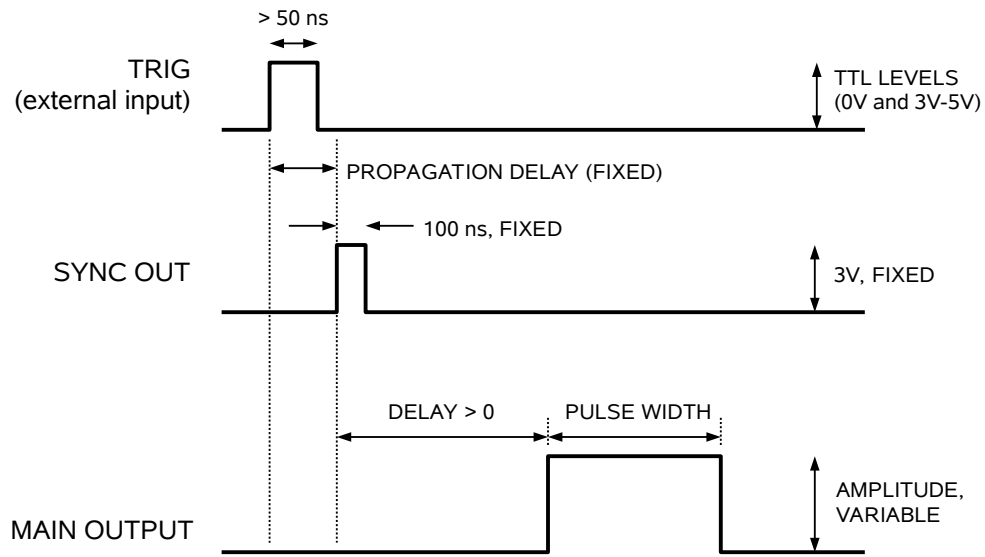

Figure C

As before, if the delay is negative, the order of the SYNC and OUT pulses is reversed.

The last figure illustrates the relationship between the signal when an external TTL-level trigger is used in the  $PW_{IN}=PW_{OUT}$  mode. In this case, the output pulse width equals the external trigger's pulse width (approximately), and the delay circuit is bypassed:

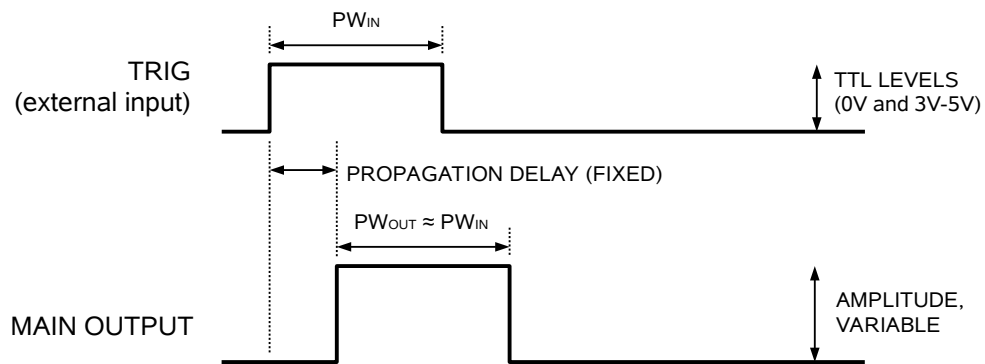

Figure D

The delay, pulse width, and frequency (when in the internal mode), of the OUT pulse can be varied with front panel controls or via the GPIB or RS-232 computer interfaces.

## TRIGGER MODES

This instrument has four trigger modes:

- Internal Trigger: the instrument controls the trigger frequency, and generates the clock internally.
- External Trigger: the instrument is triggered by an external TTL-level clock on the back-panel TRIG connector.
- Manual Trigger: the instrument is triggered by the front-panel “SINGLE PULSE” pushbutton.
- Hold Trigger: the instrument is set to not trigger at all.

These modes can be selected using the front panel trigger menu, or by using the appropriate programming commands. (See the “Programming Manual for -B Instruments” for more details.)

## PULSE WIDTH MODES

This instrument has two pulse width modes:

- Normal: the instrument controls the output pulse width.
- $PW_{IN}=PW_{OUT}$ : the output pulse width equals the pulse width of the trigger signal on the “TRIG” connector. The instrument must be in the external trigger mode.

These modes can be selected using the front panel pulse width menu, or by using the appropriate programming commands. (See the “Programming Manual for -B Instruments” for more details.)

## GATING MODES

Triggering can be suppressed by a TTL-level signal on the rear-panel GATE connector. The instrument can be set to stop triggering when this input high or low, using the front-panel gate menu or the appropriate programming commands. This input can also be set to act synchronously or asynchronously. When set to asynchronous mode, the GATE will disable the output immediately. Output pulses may be truncated. When set to synchronous mode, the output will complete the full pulse width if the output is high, and then stop triggering. No pulses are truncated in this mode.

## PREVENTING OUTPUT STAGE FAILURE

The output stage is protected against overload conditions by an overload circuit and fuses on the main frame back panel. However, the output switching elements may fail if the unit is triggered at a PRF exceeding 1 kHz or at duty cycles resulting in an average output power in excess of 40 Watts. Heating and subsequent possible failure of the output stage is reduced if the following action is taken where possible:

- PRF is kept to a minimum, i.e. operate in a low PRF range when possible rather than in a high PRF range.
- Keep the output PW to a minimum.
- Never apply an externally generated voltage to the output port.
- Reduce the amplitude below 100 Volts before changing the output polarity. Note that internal protection circuits will prevent the polarity from switching when the amplitude is set higher than  $\pm 100\text{V}$ , until the internal power supplies have discharged the voltage on the internal energy-storage capacitors to below  $\pm 100\text{V}$ . This may take several tens of seconds.

### -ADPT1 ADAPTER KIT

The standard AVR-8A-B has an SHV jack output connector. To simplify connections to other types of connectors, the -ADPT1 adapter kit is available as an option. This provides a an SHV PLUG to MHV FEMALE adapter and an MHV MALE to BNC FEMALE adapter, as shown below:

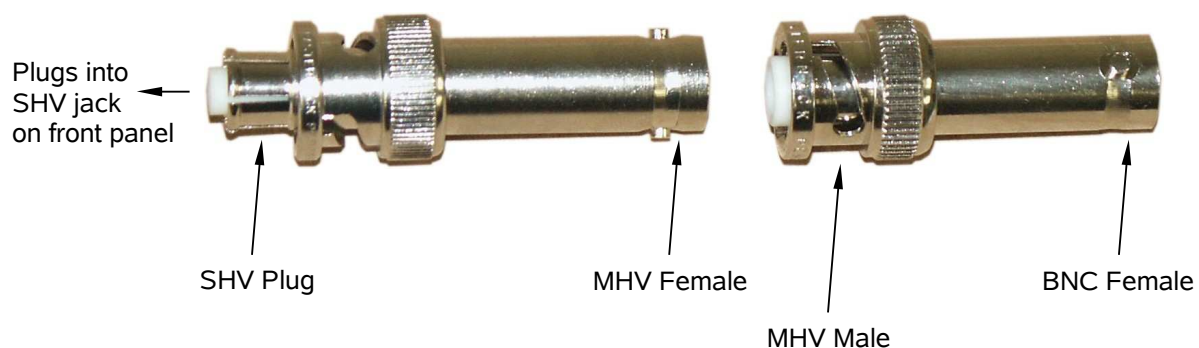

The two adapters may be used together to provide an SHV-to-BNC function.

## OUTPUT AND LOAD IMPEDANCE (STANDARD UNITS)

### OUTPUT IMPEDANCE

Standard AVR-8A-B units (without the -R50 option) have a low output impedance (nominally zero, actually  $< 2\Omega$ ). The output impedance is not  $50\Omega$ . (The output impedance refers to the internal resistance in series with the output.) The following consequences of this feature should be noted:

- When used to switch some semiconductor devices (eg. bipolar and MOSFET transistors), this pulser will yield much faster switching times than those provided by  $50\Omega$  pulse generators.
- This pulser will safely operate in to load impedances in the range of  $50\Omega$  to an open circuit. However, severe ringing may occur on the output waveform if a high-impedance load is used, due to transmission line impedance mismatching. When driving high impedance loads, it may be beneficial to add a  $50\Omega$  impedance in parallel with the high impedance load, in order to provide a proper termination for any transmission lines used.
- This pulser may be effectively converted to a  $50\Omega$  output impedance generator by placing a  $50\Omega$  ceramic composition resistor in series with the output of the unit and the load. The maximum available load voltage into a  $50\Omega$  load will then decrease to 500 Volts, from 1000 Volts.

### LOAD IMPEDANCE

The AVR-8A-B can provide voltage of up to 1000V, and currents of up to 20A. When operated at maximum amplitude, the load impedance must therefore be  $1000V / 20A = 50\Omega$ , or higher.

Best results (in terms of minimizing switching times and transmission line reflections) will be obtained with a  $50\Omega$  load.

Lower load impedances can be used at lower voltages, as long as the resulting output current does not exceed 20A. However, the rise and fall times may increase slightly due to the effects of parasitic inductance – the time constant for an inductive/resistive circuit is given by  $L/R$ , so a reduction in  $R$  will increase the parasitic time constant.

The standard AVR-8A-B (without the -R50 option) can not drive a diode load directly. A series resistance (ideally  $50\Omega$ , located very close to the diode) must be added by the user.

## OUTPUT AND LOAD IMPEDANCE (-R50 UNITS)

### -R50 OPTION

The output impedance (the internal resistance in series with the output) on standard models (without the -R50 option) is low, to allow the pulsers to act as true voltage sources ( $R_{OUT} \approx 0\Omega$ ), and to maximize the voltage output into  $50\Omega$  loads. However, for some applications it may be desirable to have  $R_{OUT}=50\Omega$ . For example, this may be a convenient method of driving laser diodes in a probing station through coaxial cables and probes. The diode DUT represents a transmission line impedance mismatch, but the resulting reflections would be absorbed by the  $50\Omega$  “back-matching” of the pulser. This allows the full specified current to be delivered to the DUT (e.g., 20A for the AVR-8A-B). The -R50 switchable output impedance option is provided for these applications. The internal  $50\Omega$  output impedance is capable of dissipating the full rated average output power of the instrument. This option increases the rise and fall times by 10 ns.

### SAMPLE WAVEFORMS FOR VARIOUS $R_{OUT}$ / $R_{LOAD}$ VALUES

Typical AVR-series waveforms are shown below, with a set amplitude of +400 V and a 1 us pulse width. The load is connected to the output connector using 6 feet / 2 meters of coaxial cabling.

|                        | $R_{OUT} = 0\Omega$  | $R_{OUT} = 50\Omega$   |
|------------------------|--|--|
| $R_{LOAD} = 22\Omega$  | <p>Ch1 Rise 50.25ns<br/>Ch1 Fall 35.59ns<br/>Ch1 +width 995.9ns<br/>Ch1 Ampl 380.0 V</p> <p>25 Feb 2020 15:18:15</p> | <p>Ch1 Rise 12.02ns<br/>Ch1 Fall 5.102ns<br/>Ch1 +width 1.004µs<br/>Ch1 Ampl 117.0 V</p> <p>25 Feb 2020 15:18:46</p> |
| $R_{LOAD} = 50\Omega$  | <p>Ch1 Rise 14.15ns<br/>Ch1 Fall 3.761ns<br/>Ch1 +width 1.002µs<br/>Ch1 Ampl 392.0 V</p> <p>25 Feb 2020 15:24:08</p> | <p>Ch1 Rise 11.88ns<br/>Ch1 Fall 5.598ns<br/>Ch1 +width 1.004µs<br/>Ch1 Ampl 194.0 V</p> <p>25 Feb 2020 15:23:41</p> |
| $R_{LOAD} = 220\Omega$ | <p>Ch1 Rise 9.668ns<br/>Ch1 Fall 4.865ns<br/>Ch1 +width 1.007µs<br/>Ch1 Ampl 396.0 V</p> <p>25 Feb 2020 15:21:06</p> | <p>Ch1 Rise 11.44ns<br/>Ch1 Fall 5.941ns<br/>Ch1 +width 1.005µs<br/>Ch1 Ampl 320.0 V</p> <p>25 Feb 2020 15:20:08</p> |
| $R_{LOAD} = \infty$    | <p>Ch1 Rise 8.671ns<br/>Ch1 Fall 8.972ns<br/>Ch1 +width 44.50ns<br/>Ch1 Ampl 432.0 V</p> <p>25 Feb 2020 15:21:59</p> | <p>Ch1 Rise 11.72ns<br/>Ch1 Fall 6.490ns<br/>Ch1 +width 1.005µs<br/>Ch1 Ampl 400.0 V</p> <p>25 Feb 2020 15:22:29</p> |

It should be observed that maximum voltages are obtained when  $R_{OUT} = 0\Omega$ , but transmission line reflections are minimized with  $R_{OUT} = 50\Omega$ . Also, regardless of the value of  $R_{OUT}$ , reflections and ringing are minimized when  $R_{LOAD} = 50\Omega$ .

The above waveforms were generated with an AVR-5B-B pulser, which is similar to the AVR-8A-B, but with lower peak voltages and slightly faster switching times.

### DRIVING A DIODE LOAD DIRECTLY

If the output impedance is set to  $50\Omega$ , the instrument can drive a diode load directly. There will be a transmission line impedance mismatch at the diode, but the reflections generated by this mismatch will be largely absorbed by the  $50\Omega$  output impedance. The reflections will not “bounce” up and down the transmission line repeatedly (just once).

This is useful for probing station setups, where a  $50\Omega$  series resistance can not be easily added to the diode load.

As an example, a BY255P-E3/54 diode was connected to the output of an AVR-5B-B using 6 feet of coaxial cabling, with the amplitude set to +500V, and the output impedance set to  $50\Omega$ . The following waveforms were obtained:

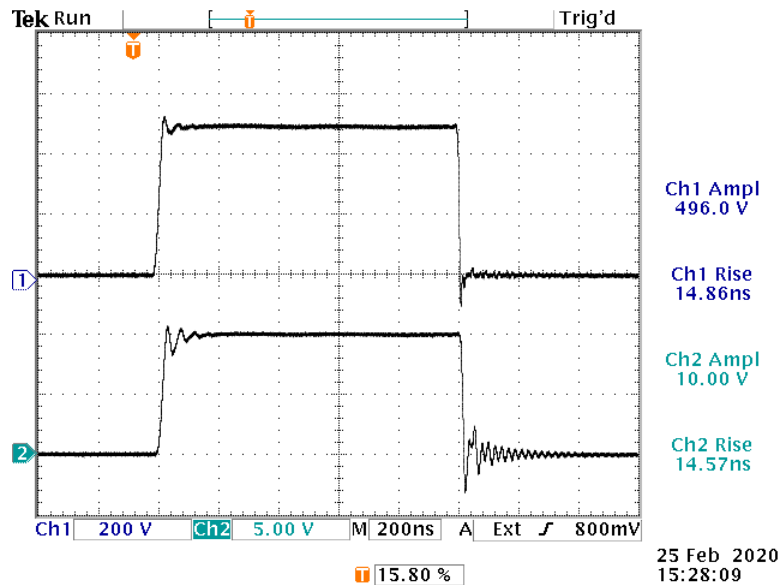

*Top: +500V pulse, internally (before  $R_{OUT}$ )  
Bottom: resulting +10A current, measured with a CT2 current probe (1V/A).*

## OPERATIONAL CHECK

This section describes a sequence to confirm the basic operation of the instrument. It should be performed after receiving the instrument. It is a useful learning exercise as well.

Before proceeding with this procedure, finish read this instruction manual thoroughly. Then read the “Local Control” section of the “Programming Manual for -B Instruments” thoroughly. The “Local Control” section describes the front panel controls used in this operational check - in particular, the MOVE, CHANGE, and ADJUST controls.

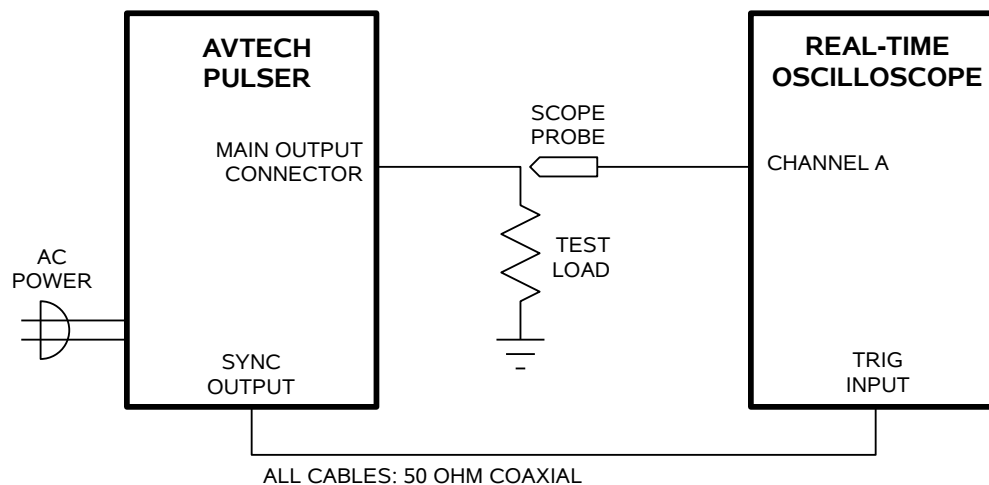

1. Connect a cable from the SYNC OUT connector to the TRIG input of an oscilloscope. Connect a 50Ω (or higher) load to the OUT connector and place the scope probe across this load. The load resistor and the scope probe must have a voltage rating of at least 1000V. The power dissipated in the resistor is given by

$$P = (V^2 / R) \times (PW / T) = (V^2 / R) \times PW \times f$$

where “V” is the output voltage, “R” is the load resistance, “PW” is the pulse width, and “T” is the pulse period (1/frequency), and “f” is the frequency. If a 50Ω resistor is used, the worst-case power dissipation is 40 Watts. Factory tests are conducted using twenty 10Ω, 2W resistors connected in a series-parallel combination to make a 50Ω, 40W composite load. Fan cooling the resistors allows for slightly higher power dissipation. (Ohmite “OY” ceramic composition resistors - <http://www.ohmite.com> - are recommended for such applications. These resistors are readily available from <http://www.digi-key.com/> and other distributors.)

2. Set the oscilloscope to trigger externally with the vertical setting at 200 Volts/div and the horizontal setting at 1 us/div. Be sure that your oscilloscope and probe setup can handle the maximum amplitude of 1000V. A high-voltage attenuator might be



necessary to avoid damaging the probe and oscilloscope. The 50 $\Omega$  load resistor should be rated for at least 1000V of voltage and 40W of power.

3. Turn on the AVR-8A-B. The main menu will appear on the LCD.
4. To set the AVR-8A-B to trigger from the internal clock at a PRF of 1 kHz:
  - The arrow pointer should be pointing at the frequency menu item. If it is not, press the MOVE button until it is.
  - Press the CHANGE button. The frequency submenu will appear. Rotate the ADJUST knob until the frequency is set at 1 kHz.
  - The arrow pointer should be pointing at the “Internal” choice. If it is not, press MOVE until it is.
  - Press CHANGE to return to the main menu.
5. To set the delay to 1 us:
  - Press the MOVE button until the arrow pointer is pointing at the delay menu item.
  - Press the CHANGE button. The delay submenu will appear. Rotate the ADJUST knob until the delay is set at 1 us.
  - The arrow pointer should be pointing at the “Normal” choice. If it is not, press MOVE until it is.
  - Press CHANGE to return to the main menu.
6. To set the pulse width to 1 us:
  - Press the MOVE button until the arrow pointer is pointing at the pulse width menu item.
  - Press the CHANGE button. The pulse width submenu will appear. Rotate the ADJUST knob until the pulse width is set at 1 us.
  - The arrow pointer should be pointing at the “Normal” choice. If it is not, press MOVE until it is.
  - Press CHANGE to return to the main menu.
7. At this point, nothing should appear on the oscilloscope.

8. To enable the output:
  - Press the MOVE button until the arrow pointer is pointing at the output menu item.
  - Press the CHANGE button. The output submenu will appear.
  - Press MOVE until the arrow pointer is pointing at the “ON” choice.
  - Press CHANGE to return to the main menu.
  
9. To change the output amplitude:
  - Press the MOVE button until the arrow pointer is pointing at the amplitude menu item.
  - Press the CHANGE button. The amplitude submenu will appear. Rotate the ADJUST knob until the amplitude is set at +200V (or -200V for "-N" instruments).
  - Observe the oscilloscope. You should see 1 us wide, 200V pulses.
  - Rotate the ADJUST knob. The amplitude as seen on the oscilloscope should vary.
  - Reduce the amplitude to 50V (or -50V for "-N" instruments), using the adjust knob.
  - *For "-PN" units only:* Change the output polarity by pressing the “+/-” button. The output amplitude should become negative, and you should see -50V pulses on the oscilloscope. (Avoid switching polarity when the amplitude is higher than 100V. Reduce the amplitude first.)
  - Rotate the ADJUST knob. The amplitude as seen on the oscilloscope should vary.
  - Press CHANGE to return to the main menu.
  
10. Repeat step 9, but set the amplitude to zero.
  
11. This completes the operational check.

## PROGRAMMING YOUR PULSE GENERATOR

### KEY PROGRAMMING COMMANDS

The “Programming Manual for -B Instruments” describes in detail how to connect the pulse generator to your computer, and the programming commands themselves. A large number of commands are available; however, normally you will only need a few of these. Here is a basic sample sequence of commands that might be sent to the instrument after power-up:

|                         |                                 |
|-------------------------|---------------------------------|
| *rst                    | (resets the instrument)         |
| trigger:source internal | (selects internal triggering)   |
| frequency 1000 Hz       | (sets the frequency to 1000 Hz) |
| pulse:width 1 us        | (sets the pulse width to 1 us)  |
| pulse:delay 2 us        | (sets the delay to 2 us)        |
| volt 200                | (sets the amplitude to 200 V)   |
| output on               | (turns on the output)           |

For triggering a single event, this sequence would be more appropriate:

|                          |   |
|--------------------------|---|
| *rst                     | (resets the instrument)                           |
| trigger:source hold      | (turns off all triggering)                        |
| pulse:width 1 us         | (sets the pulse width to 1 us)                    |
| pulse:delay 2 us         | (sets the delay to 2 us)                          |
| output on                | (turns on the output)                             |
| volt 200                 | (sets the amplitude to 200 V)                     |
| trigger:source immediate | (generates a single non-repetitive trigger event) |
| trigger:source hold      | (turns off all triggering)                        |
| output off               | (turns off the output)                            |

To set the instrument to trigger from an external TTL signal applied to the rear-panel TRIG connector, use:

|                         |                                |
|-------------------------|--------------------------------|
| *rst                    | (resets the instrument)        |
| trigger:source external | (selects external triggering)  |
| pulse:width 1 us        | (sets the pulse width to 1 us) |
| pulse:delay 2 us        | (sets the delay to 2 us)       |
| volt 200                | (sets the amplitude to 200 V)  |
| output on               | (turns on the output)          |

These commands will satisfy 90% of your programming needs.

## ALL PROGRAMMING COMMANDS

For more advanced programmers, a complete list of the available commands is given below. These commands are described in detail in the “Programming Manual for -B Instruments”. (Note: this manual also includes some commands that are not implemented in this instrument. They can be ignored.)

| <u>Keyword</u> | <u>Parameter</u>   | <u>Notes</u>                     |
|----------------|--|----------------------------------|
| OUTPut:        |  |                                  |
| :[STATe]       | <boolean value>  |                                  |
| :PROTection    |  |                                  |
| :TRIPped?      |  | [query only]                     |
| [SOURce]:      |  |                                  |
| :FREQuency     |  |                                  |
| [:CW   FIXed]  | <numeric value>  |                                  |
| [SOURce]:      |  |                                  |
| :PULSe         |  |                                  |
| :PERiod        | <numeric value>  |                                  |
| :WIDTh         | <numeric value>   EXTernal                                 |                                  |
| :DCYClE        | <numeric value>  |                                  |
| :HOLD          | WIDTh   DCYClE   |                                  |
| :DELay         | <numeric value>  |                                  |
| :GATE          |  |                                  |
| :TYPE          | ASYNc   SYNc   |                                  |
| :LEVel         | HIgh   LOw   |                                  |
| [SOURce]:      |  |                                  |
| :VOLTage       |  |                                  |
| [:LEVel]       |  |                                  |
| [:IMMEDIATE]   |  |                                  |
| [:AMPLitude]   | <numeric value>   EXTernal                                 |                                  |
| :PROTection    |  |                                  |
| :TRIPped?      |  | [query only]                     |
| STATUS:        |  |                                  |
| :OPERation     |  |                                  |
| :[EVENT]?      |  | [query only, always returns "0"] |
| :CONDition?    |  | [query only, always returns "0"] |
| :ENABle        | <numeric value>  | [implemented but not useful]     |
| :QUESTionable  |  |                                  |
| :[EVENT]?      |  | [query only, always returns "0"] |
| :CONDition?    |  | [query only, always returns "0"] |
| :ENABle        | <numeric value>  | [implemented but not useful]     |
| SYSTEM:        |  |                                  |
| :COMMunicate   |  |                                  |
| :GPIB          |  |                                  |
| :ADDReSS       | <numeric value>  |                                  |
| :SERial        |  |                                  |
| :CONTRol       |  |                                  |
| :RTS           | ON   IBFull   RFR  |                                  |
| :[RECEive]     |  |                                  |
| :BAUD          | 1200   2400   4800   9600   19200   38400   57600   115200 |                                  |
| :ERRor         |  |                                  |
| :[NEXT]?       |  | [query only]                     |
| :COUNT?        |  | [query only]                     |
| :VERSion?      |  | [query only]                     |
| TRIGger:       |  |                                  |

|         |   |                 |
|---------|---|-----------------|
| :SOURce | INTernal   EXTernal   MANual   HOLD   IMMEDIATE |                 |
| *CLS    |   | [no query form] |
| *ESE    | <numeric value>                                 |                 |
| *ESR?   |   | [query only]    |
| *IDN?   |   | [query only]    |
| *OPC    |   |                 |
| *SAV    | 0   1   2   3                                   | [no query form] |
| *RCL    | 0   1   2   3                                   | [no query form] |
| *RST    |   | [no query form] |
| *SRE    | <numeric value>                                 |                 |
| *STB?   |   | [query only]    |
| *TST?   |   | [query only]    |
| *WAI    |   | [no query form] |

## MECHANICAL INFORMATION

### TOP COVER REMOVAL

If necessary, the interior of the instrument may be accessed by removing the four Phillips screws on the top panel. With the four screws removed, the top cover may be slid back (and off).

 Always disconnect the power cord and allow the instrument to sit unpowered for 10 minutes before opening the instrument. This will allow any internal stored charge to discharge.

There are no user-adjustable internal circuits. For repairs other than fuse replacement, please contact Avtech (info@avtechpulse.com) to arrange for the instrument to be returned to the factory for repair. Service is to be performed solely by qualified service personnel.

 Caution: High voltages are present inside the instrument during normal operation. Do not operate the instrument with the cover removed.

### RACK MOUNTING

A rack mounting kit is available. The -R5 rack mount kit may be installed after first removing the one Phillips screw on the side panel adjacent to the front handle.

### ELECTROMAGNETIC INTERFERENCE

To prevent electromagnetic interference with other equipment, all used outputs should be connected to shielded loads using shielded coaxial cables. Unused outputs should be terminated with shielded coaxial terminators or with shielded coaxial dust caps, to prevent unintentional electromagnetic radiation. All cords and cables should be less than 3m in length.

## MAINTENANCE

### REGULAR MAINTENANCE

This instrument does not require any regular maintenance.

On occasion, one or more of the four rear-panel fuses may require replacement. All fuses can be accessed from the rear panel. See the “FUSES” section for details.

### CLEANING

If desired, the interior of the instrument may be cleaned using compressed air to dislodge any accumulated dust. (See the “TOP COVER REMOVAL” section for instructions on accessing the interior.) No other cleaning is recommended.







# WIRING OF DC POWER SUPPLIES

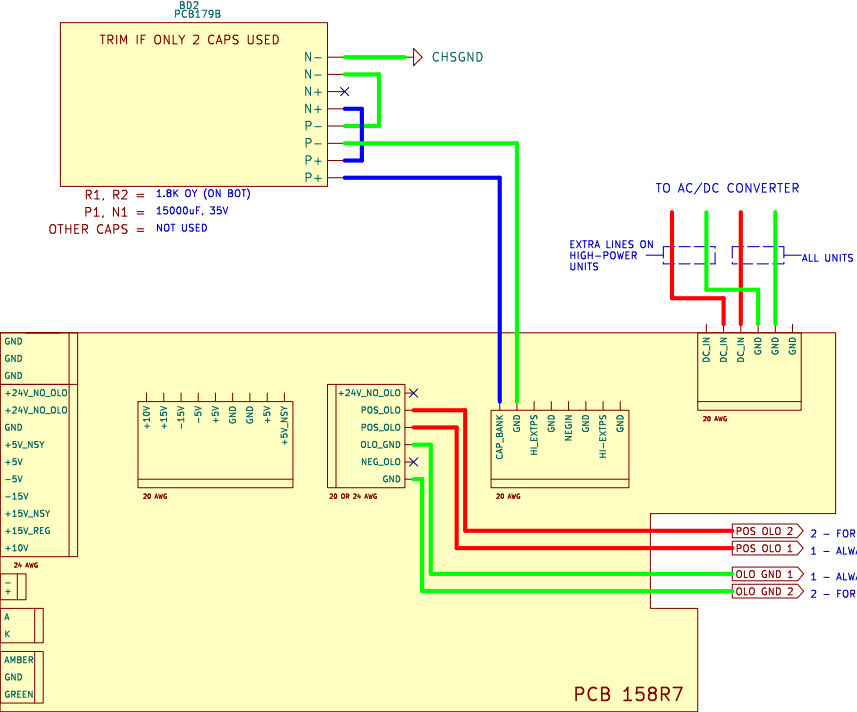
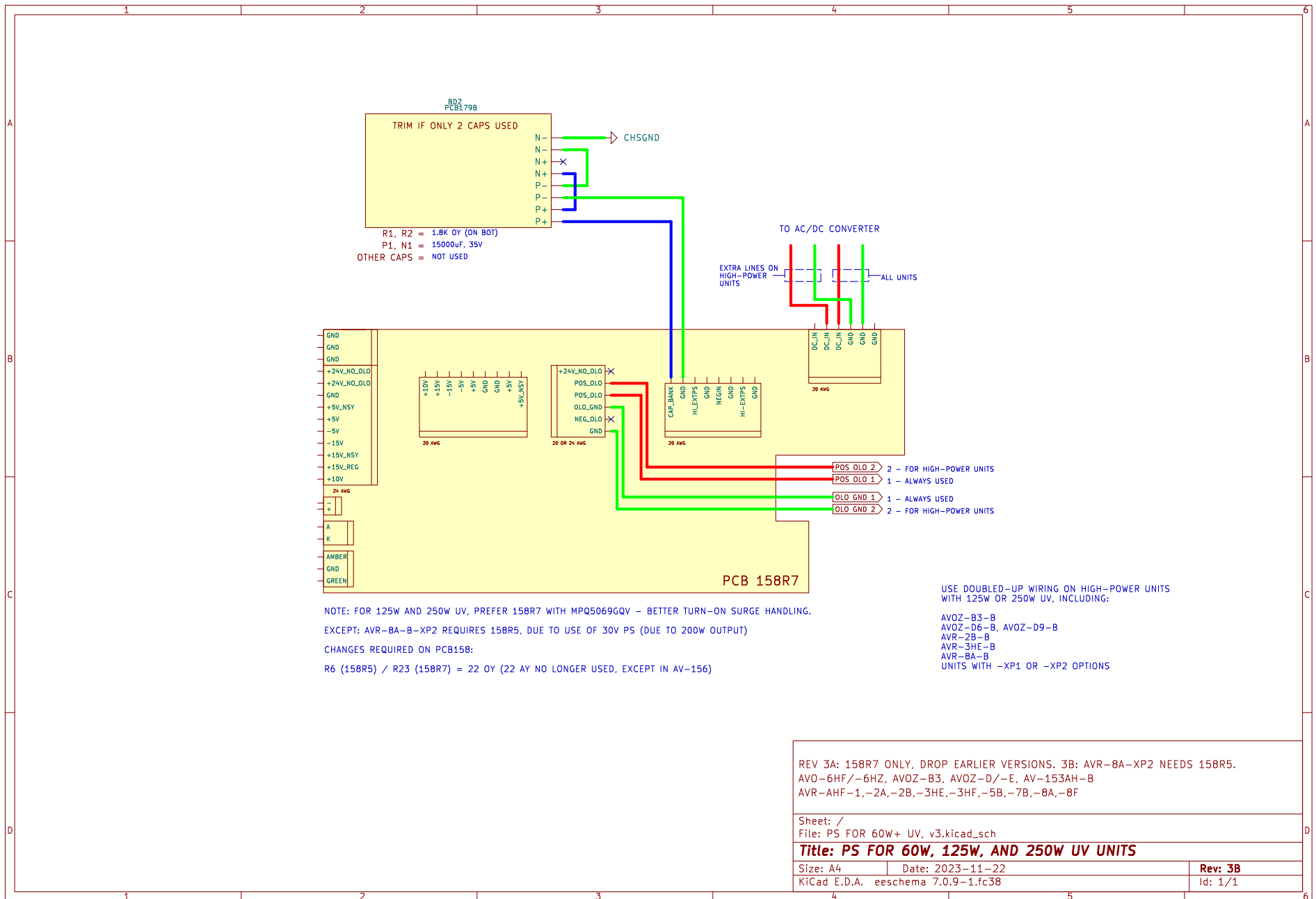

NOTE: FOR 125W AND 250W UV, PREFER 158R7 WITH MPQ5069GQV - BETTER TURN-ON SURGE HANDLING.  
EXCEPT: AVR-8A-B-XP2 REQUIRES 158R5, DUE TO USE OF 30V PS (DUE TO 200W OUTPUT)  
CHANGES REQUIRED ON PCB158:  
R6 (158R5) / R23 (158R7) = 22 OY (22 AY NO LONGER USED, EXCEPT IN AV-156)

USE DOUBLED-UP WIRING ON HIGH-POWER UNITS WITH 125W OR 250W UV, INCLUDING:  
AVOZ-B3-B  
AVOZ-D6-B, AVOZ-D9-B  
AVR-2B-B  
AVR-3HE-B  
AVR-8A-B  
UNITS WITH -XP1 OR -XP2 OPTIONS

|   |                    |
|---|--------------------|
| REV 3A: 158R7 ONLY, DROP EARLIER VERSIONS. 3B: AVR-8A-XP2 NEEDS 158R5.<br>AVO-6HF/-6HZ, AVOZ-B3, AVOZ-D/-E, AV-153AH-B<br>AVR-AHF-1,-2A,-2B,-3HE,-3HF,-5B,-7B,-8A,-8F |                    |
| Sheet: /  |                    |
| File: PS FOR 60W+ UV, v3.kicad_sch  |                    |
| <b>Title: PS FOR 60W, 125W, AND 250W UV UNITS</b>   |                    |
| Size: A4  | Date: 2023-11-22   |
| KiCad E.D.A. eeschema 7.0.9-1.fc38  | Rev: 3B<br>Id: 1/1 |

# PCB 158R7 - LOW VOLTAGE POWER SUPPLY (STANDARD UNITS)

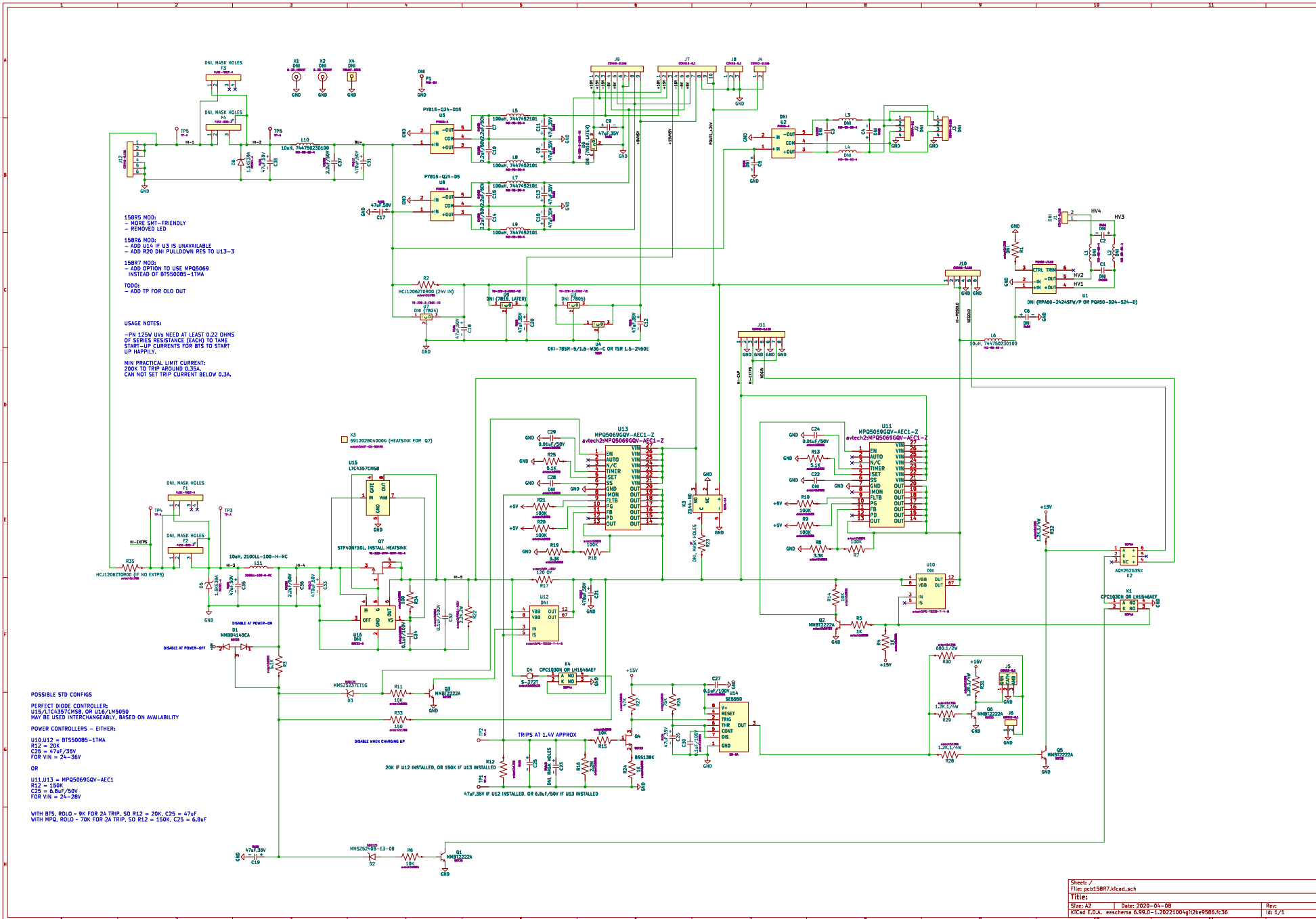

# PCB 158R5 - LOW VOLTAGE POWER SUPPLY (-XP2 UNITS)

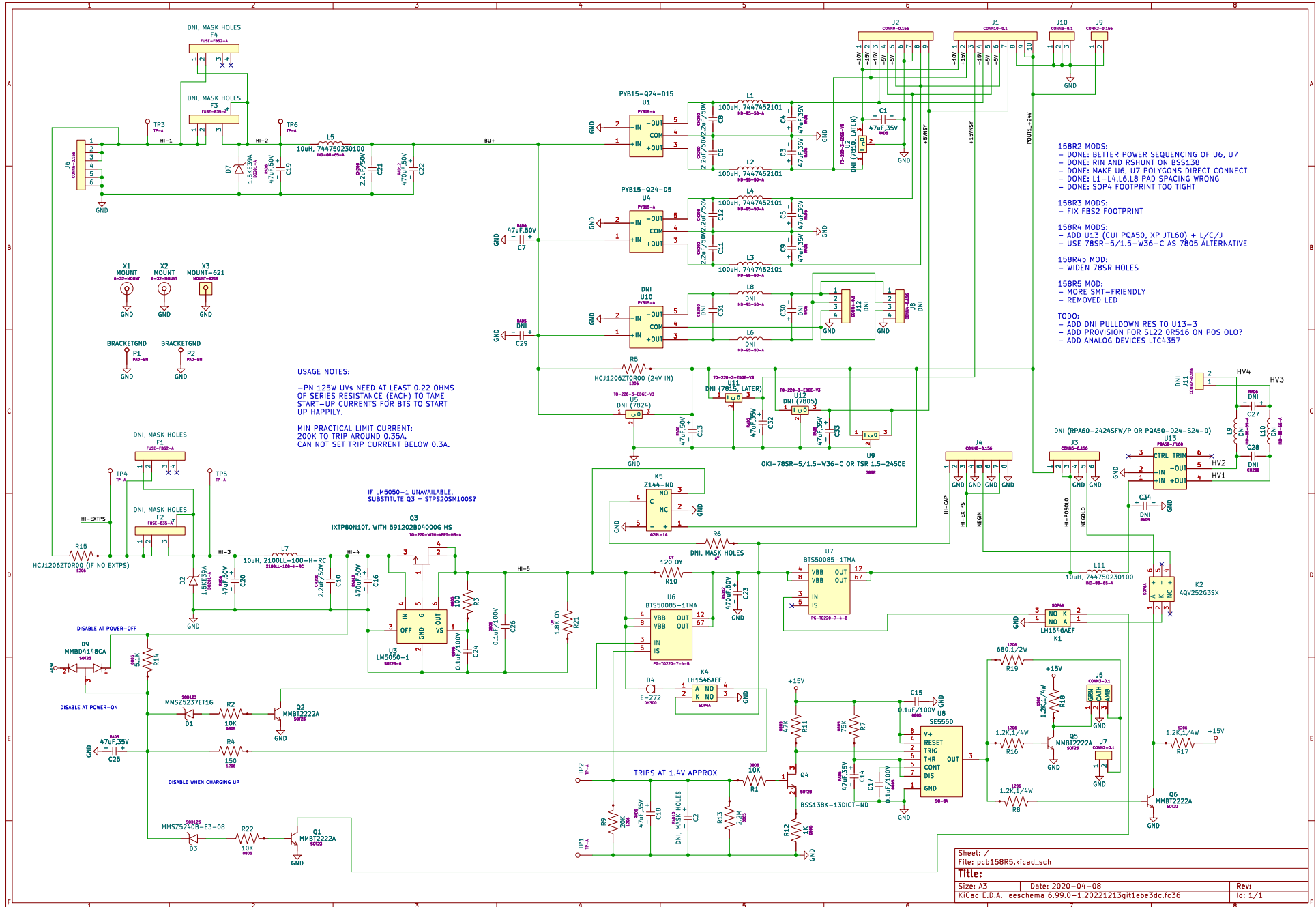

# PCB 156E - POLARITY CONTROL PCB

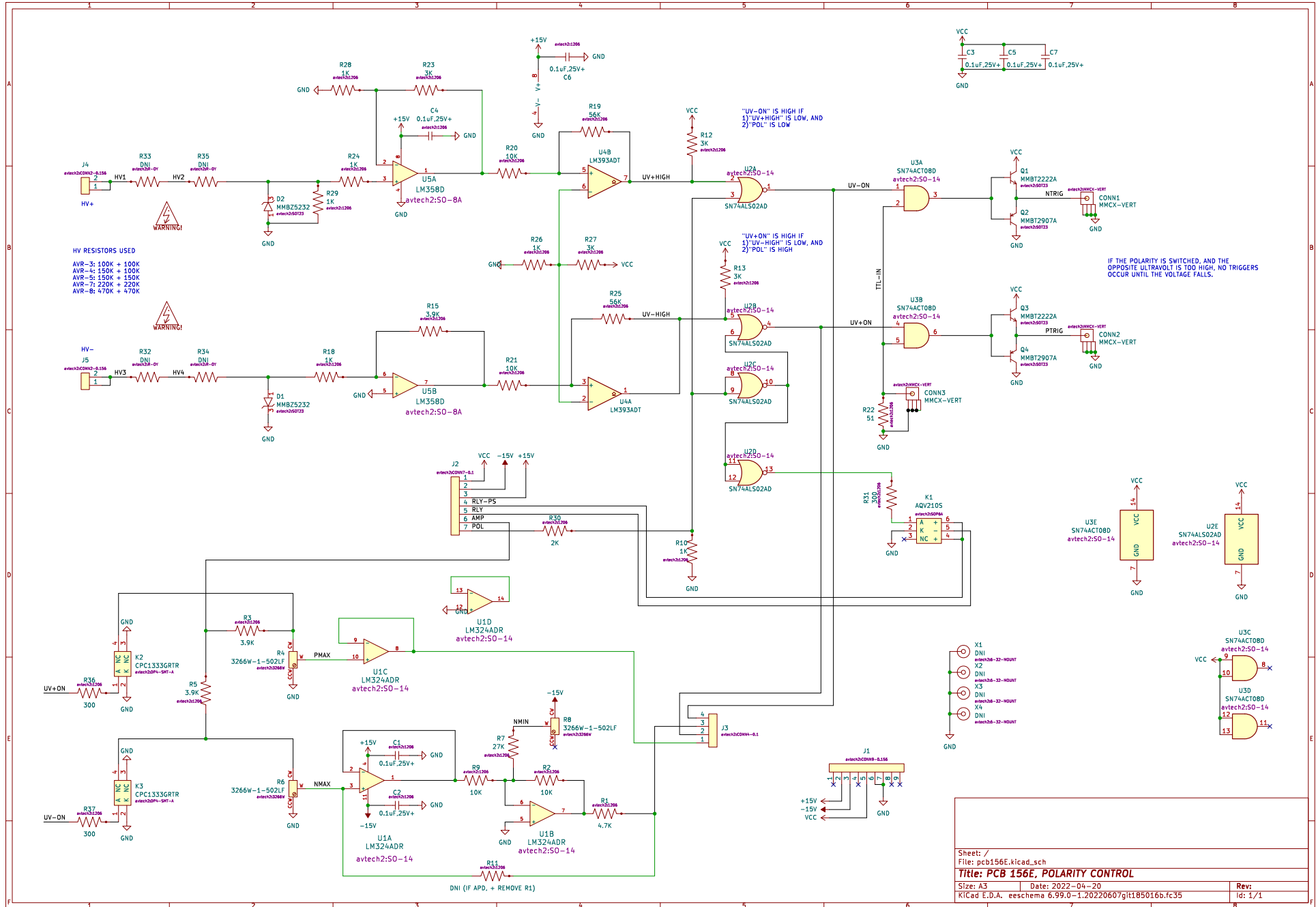



# PCB 183A-S AND 183A-P CAPACITOR BANKS

## 183A-S (SERIES CAPACITOR BANK)

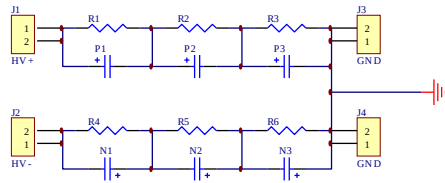

## 183A-P (PARALLEL CAPACITOR BANK)

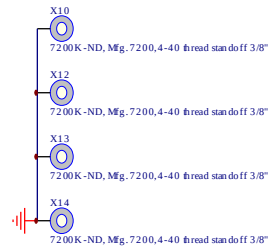
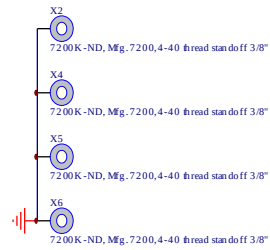
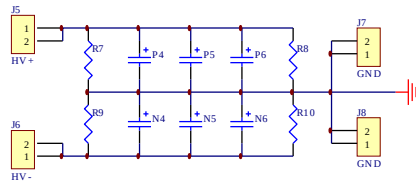

### PCB183 CAP BANKS

Printed 19-Aug-2005

Revision 1C

Z:\mjrfiles\pcb183\hv-cap-bank.Ddb - pcb183a.sch

# PCB 341A - INTERLOCK BOARD

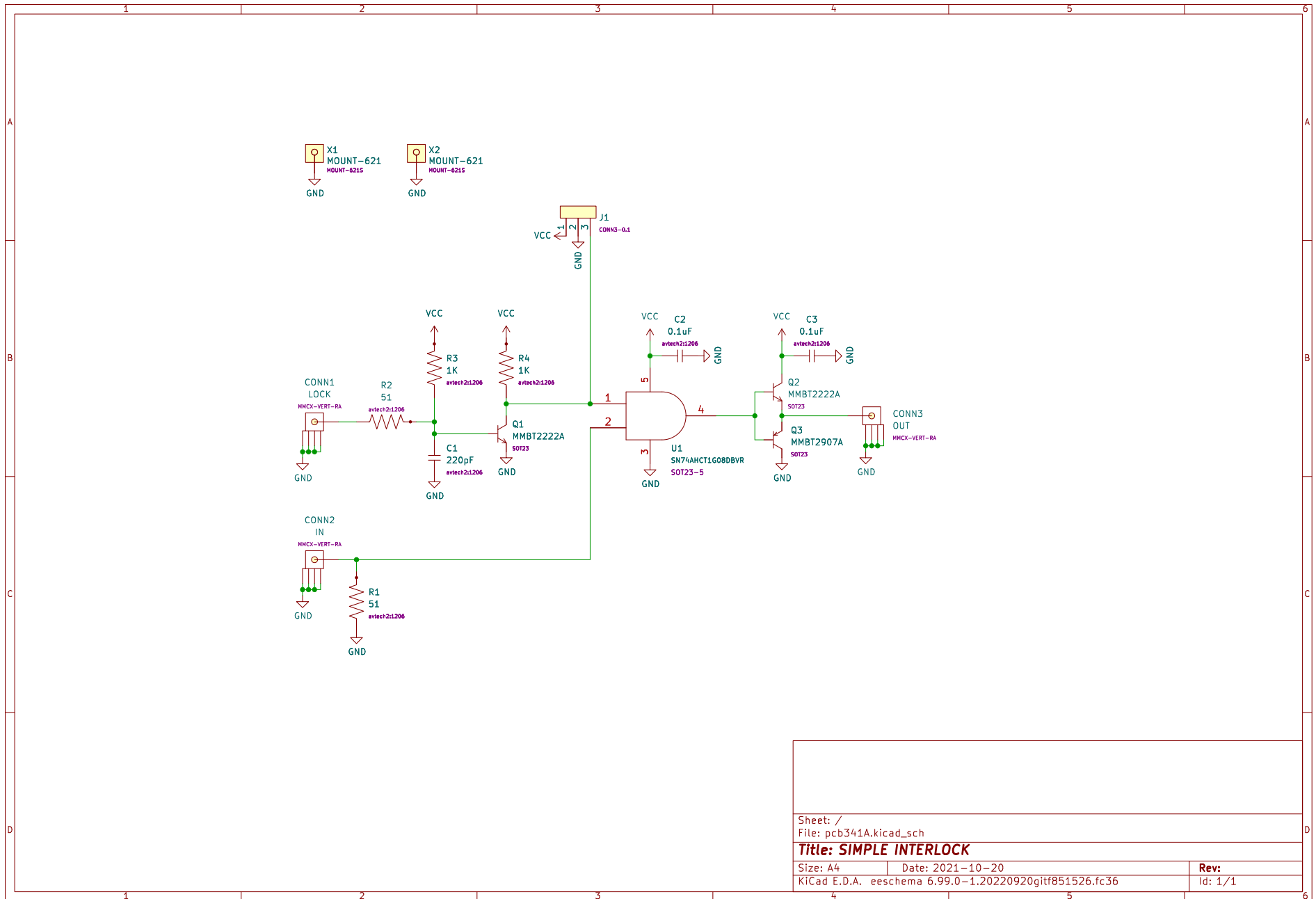

|  |                  |
|--|------------------|
| Sheet: /   |                  |
| File: pcb341A.kicad_sch                                |                  |
| <b>Title: SIMPLE INTERLOCK</b>                         |                  |
| Size: A4   | Date: 2021-10-20 |
| KiCad E.D.A. eeschema 6.99.0-1.20220920gitf851526.fc36 | Rev: 1/1         |



# PCB 104H - KEYPAD / DISPLAY BOARD

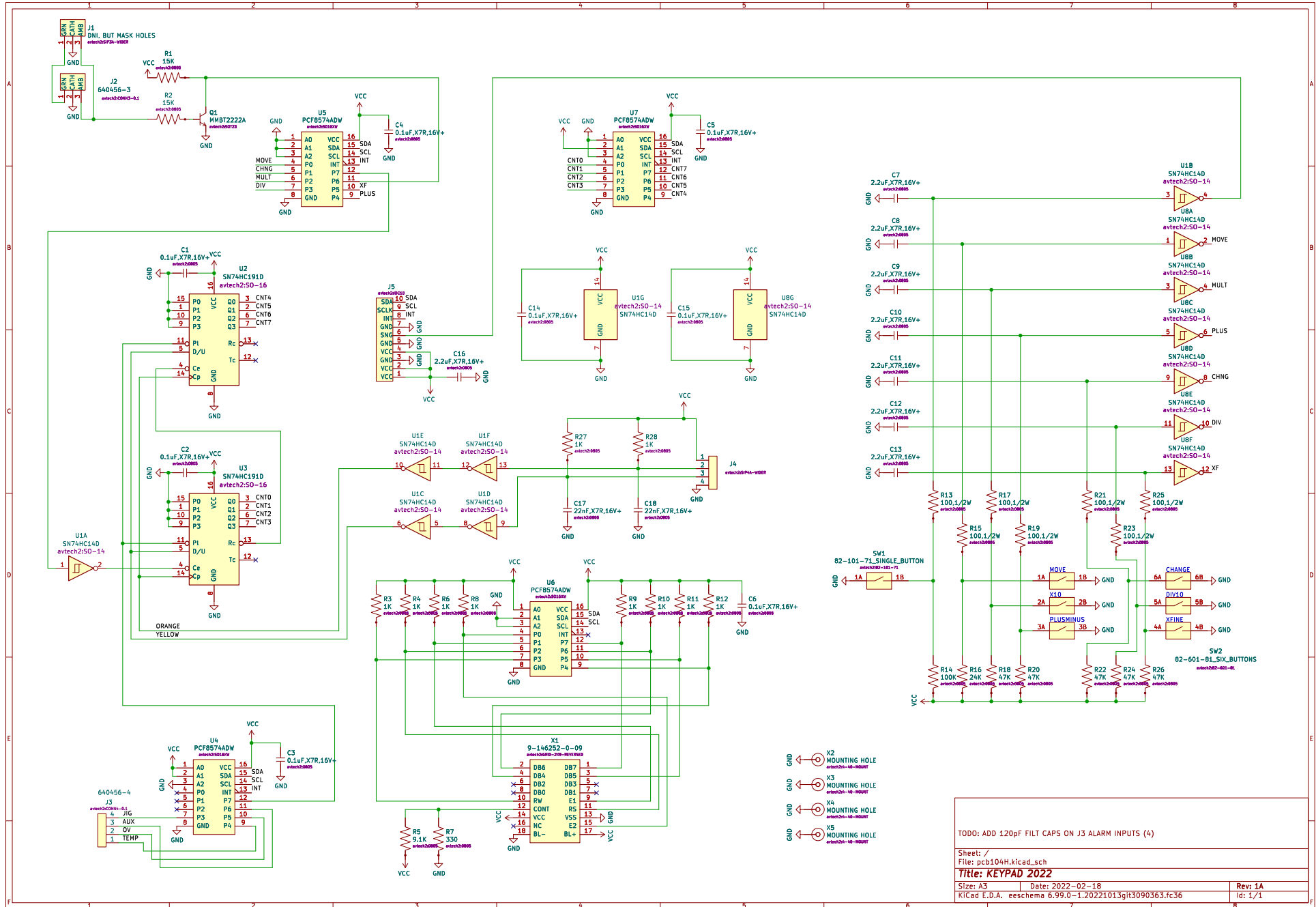

|  |                         |
|--|-------------------------|
| TODD: ADD 120pF FILT CAPS ON J3 ALARM INPUTS (4)       |                         |
| Sheet: /   | File: pcb104H.kicad_sch |
| Title: KEYPAD 2022                                     |                         |
| Size: A3   | Date: 2022-02-18        |
| KiCad E.D.A. eeschema 6.99.0-1.20221013git3090363.fc36 | Id: 1/1                 |
| Rev: 1A  |                         |

# PCB 295G - MAIN CONTROL BOARD, 1 OF 13, TOP-LEVEL

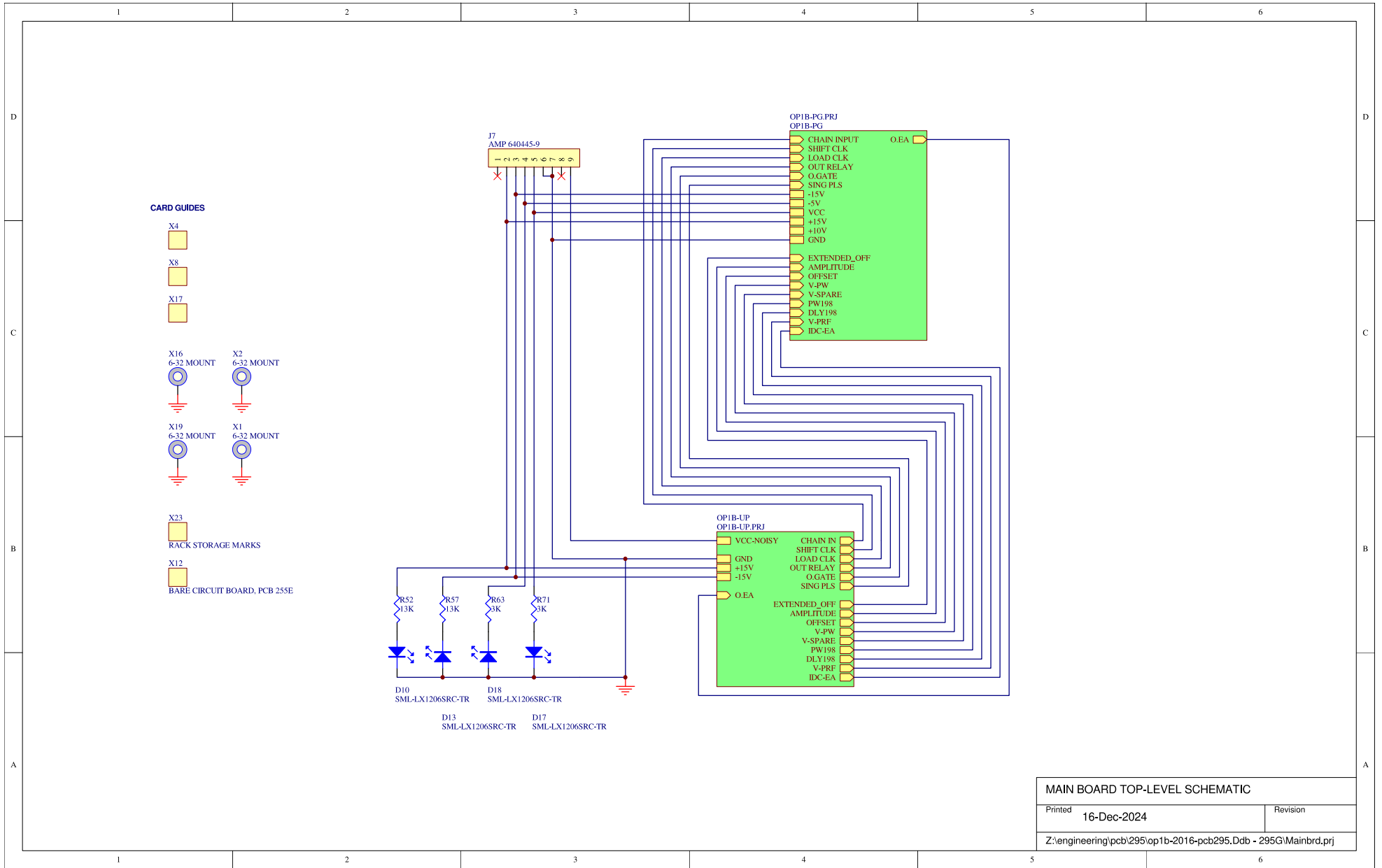

| MAIN BOARD TOP-LEVEL SCHEMATIC                                 |          |
|--|----------|
| Printed 16-Dec-2024  | Revision |
| Z:\engineering\pcb\295\op1b-2016-pcb295.Ddb - 295G>Mainbrd.prj |          |

# PCB 295G - MAIN CONTROL BOARD, 2 OF 13, MICROCONTROLLER TOP-LEVEL

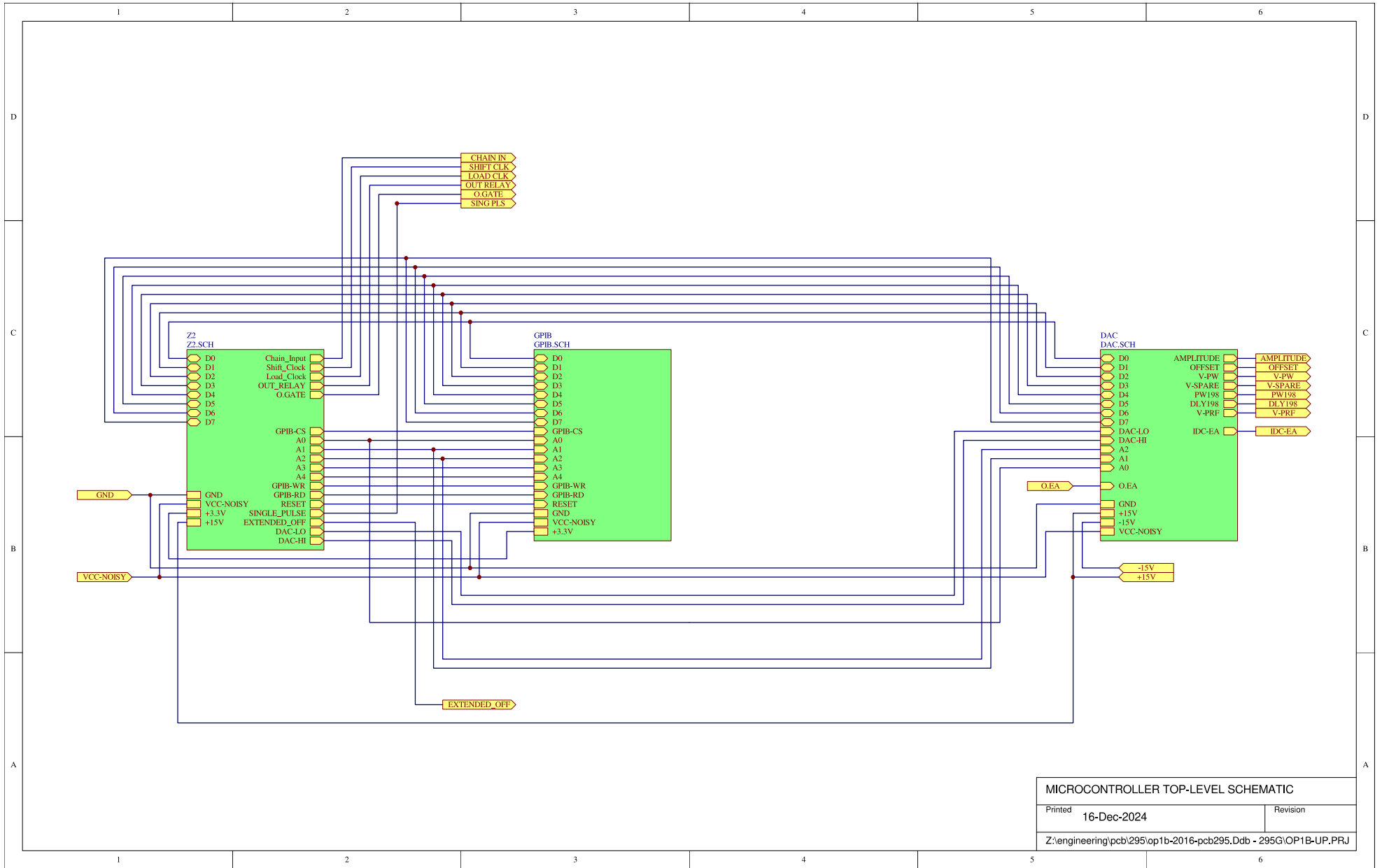

| MICROCONTROLLER TOP-LEVEL SCHEMATIC                            |             |
|--|-------------|
| Printed  | 16-Dec-2024 |
| Revision   |             |
| Z:\engineering\pcb\295\op1b-2016-pcb295.Ddb - 295G\OP1B-UP.PRJ |             |

# PCB 295G - MAIN CONTROL BOARD, 3 OF 13, EMBEDDED CONTROLLER

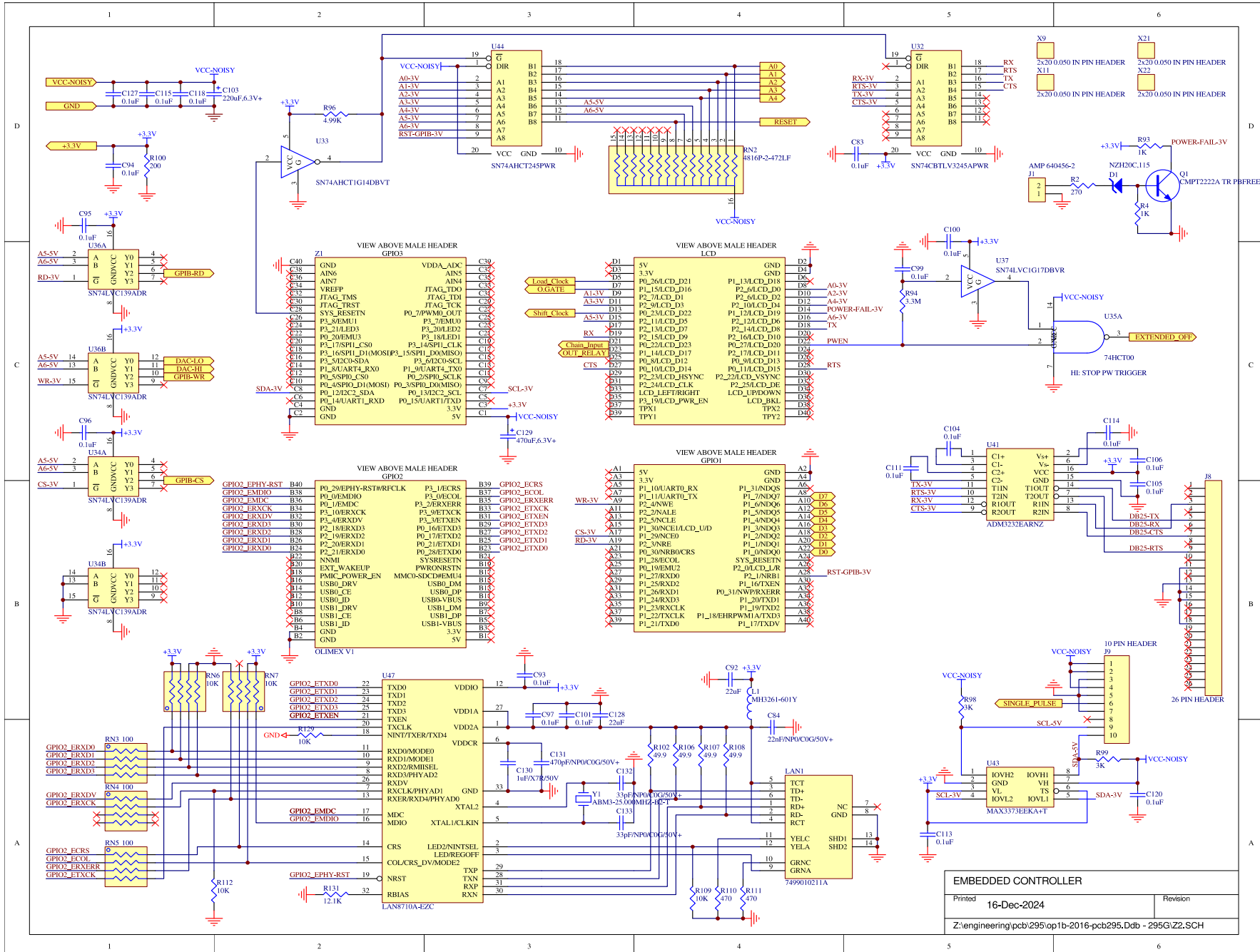

# PCB 295G - MAIN CONTROL BOARD, 4 OF 13, GPIB INTERFACE

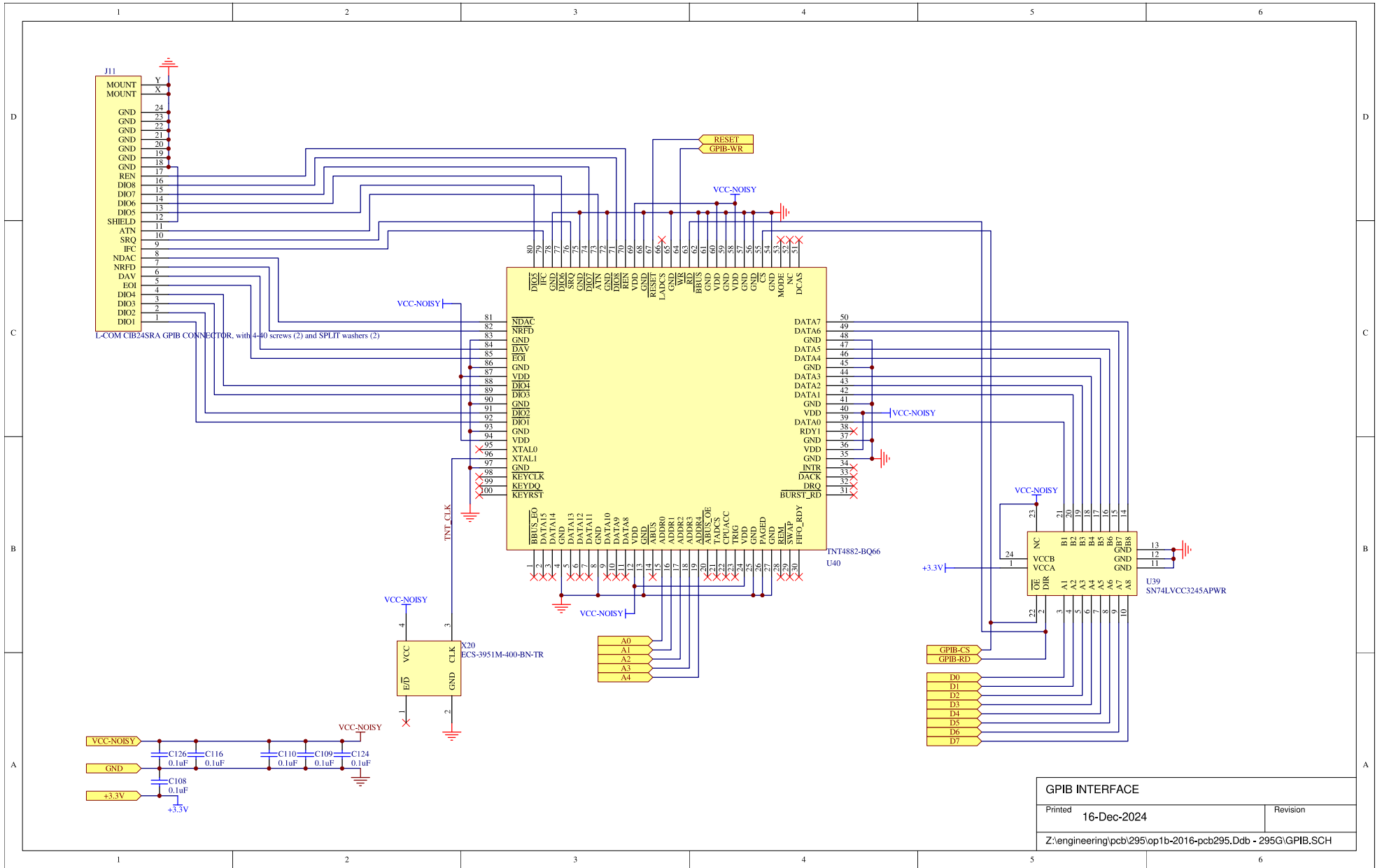

| GPIB INTERFACE  |          |
|---|----------|
| Printed   | Revision |
| 16-Dec-2024   |          |
| Z:\engineering\pcb\295\op1b-2016-pcb295.Ddb - 295G\GPIB.SCH |          |

# PCB 295G - MAIN CONTROL BOARD, 5 OF 13, DACs

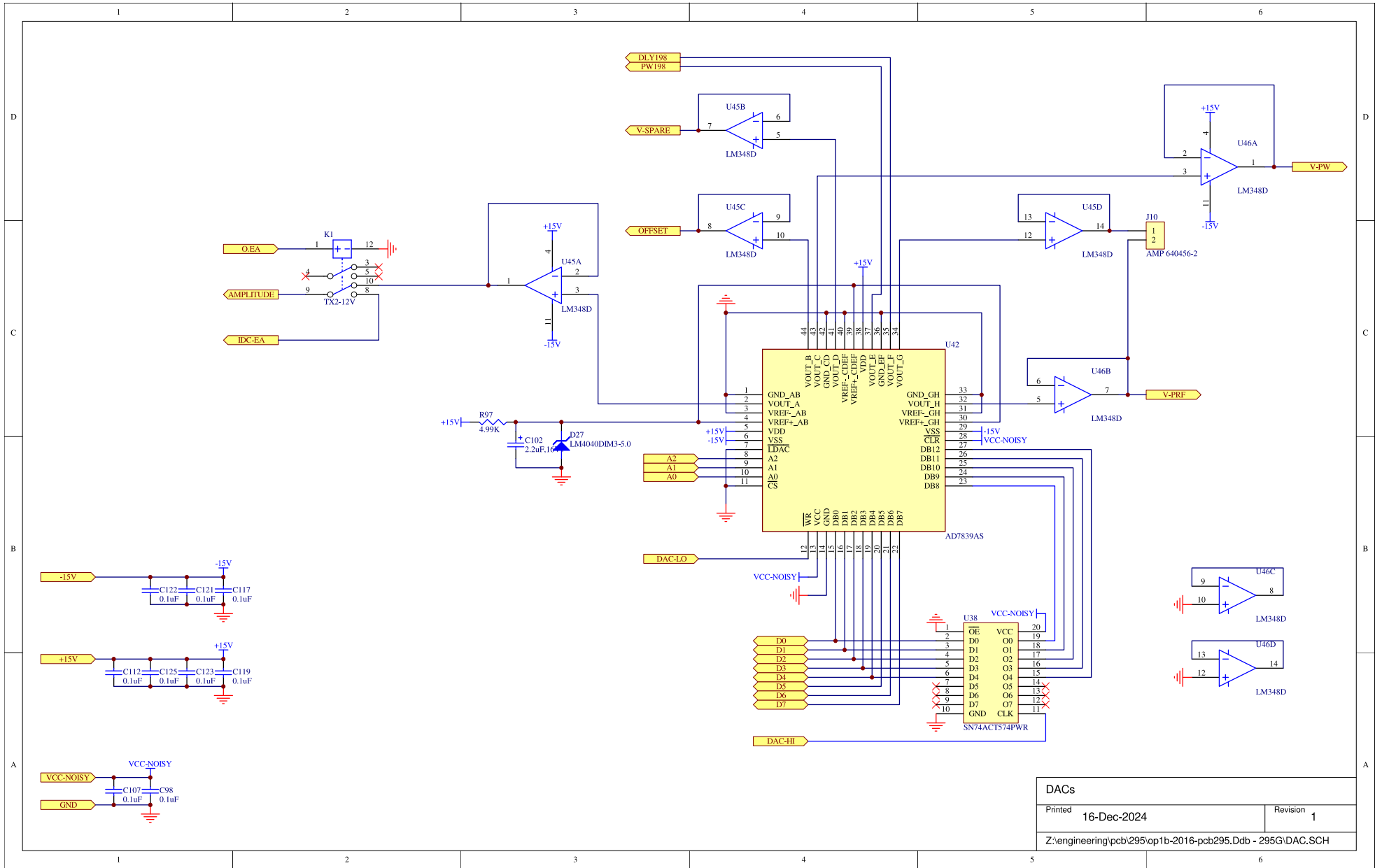

| DACs   |             |
|--|-------------|
| Printed  | 16-Dec-2024 |
| Revision   | 1           |
| Z:\engineering\pcb\295\op1b-2016-pcb295.Ddb - 295G/DAC.SCH |             |

# PCB 295G - MAIN CONTROL BOARD, 6 OF 13, TIMING TOP-LEVEL

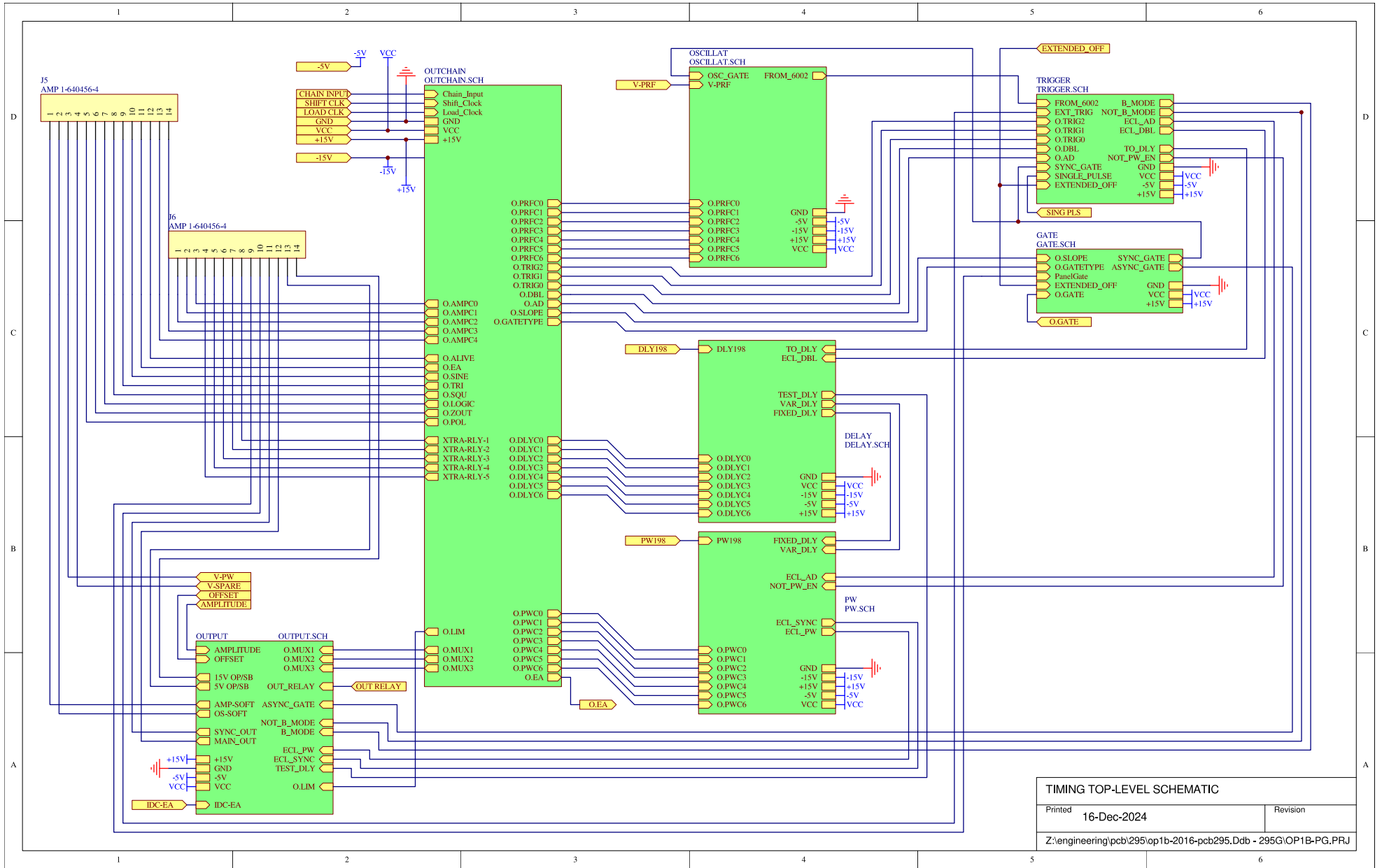

| TIMING TOP-LEVEL SCHEMATIC                                      |          |
|---|----------|
| Printed   | Revision |
| 16-Dec-2024   |          |
| Z:\engineering\pcb\295\op1b-2016-pcb295.Ddb - 295G\OP1B-PG_P RJ |          |

# PCB 295G - MAIN CONTROL BOARD, 7 OF 13, GATE CIRCUIT

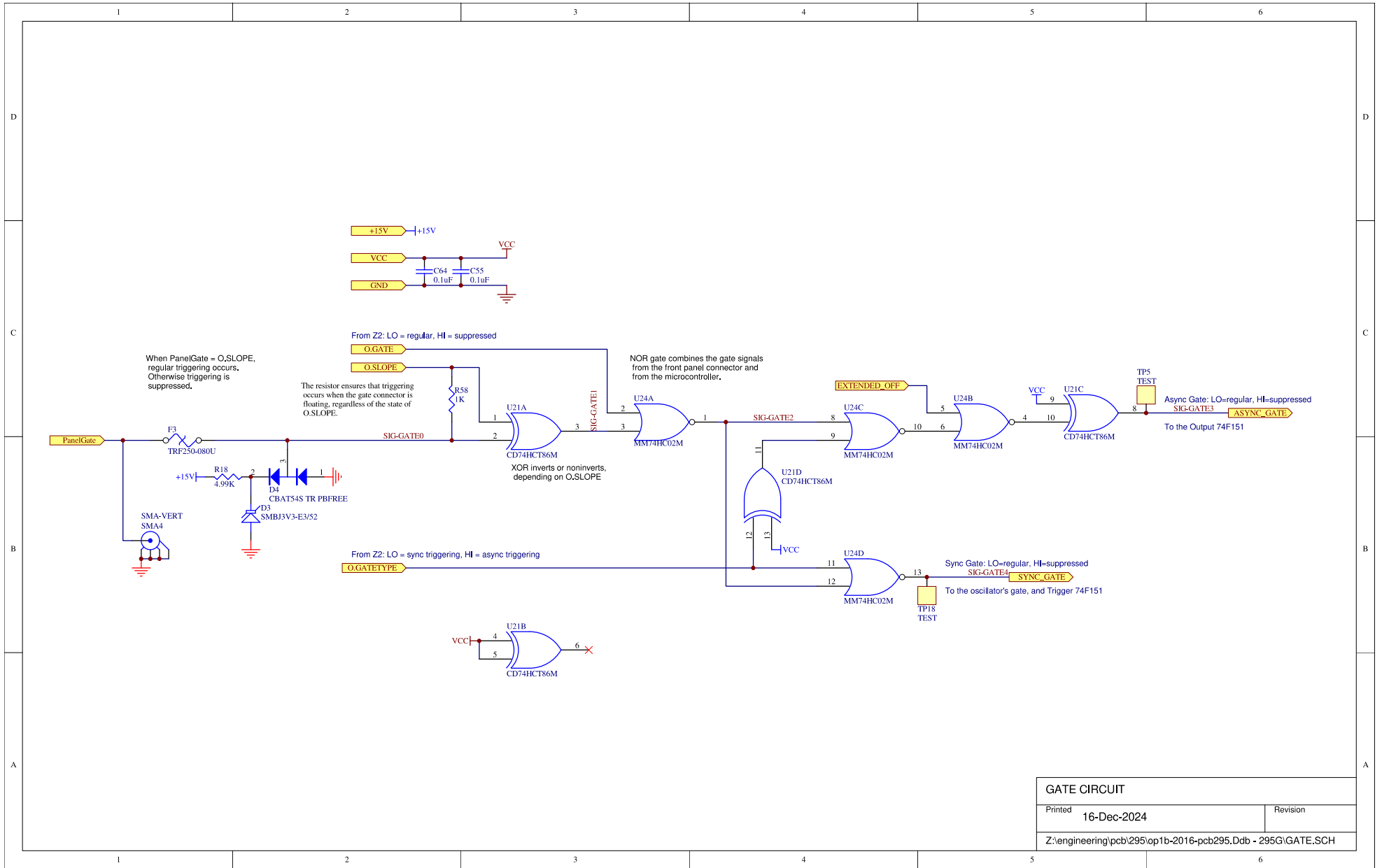

| GATE CIRCUIT  |          |
|---|----------|
| Printed 16-Dec-2024   | Revision |
| Z:\engineering\pcb\295\op1b-2016-pcb295.Ddb - 295G\GATE.SCH |          |



# PCB 295G - MAIN CONTROL BOARD, 8 OF 13, OSCILLATOR

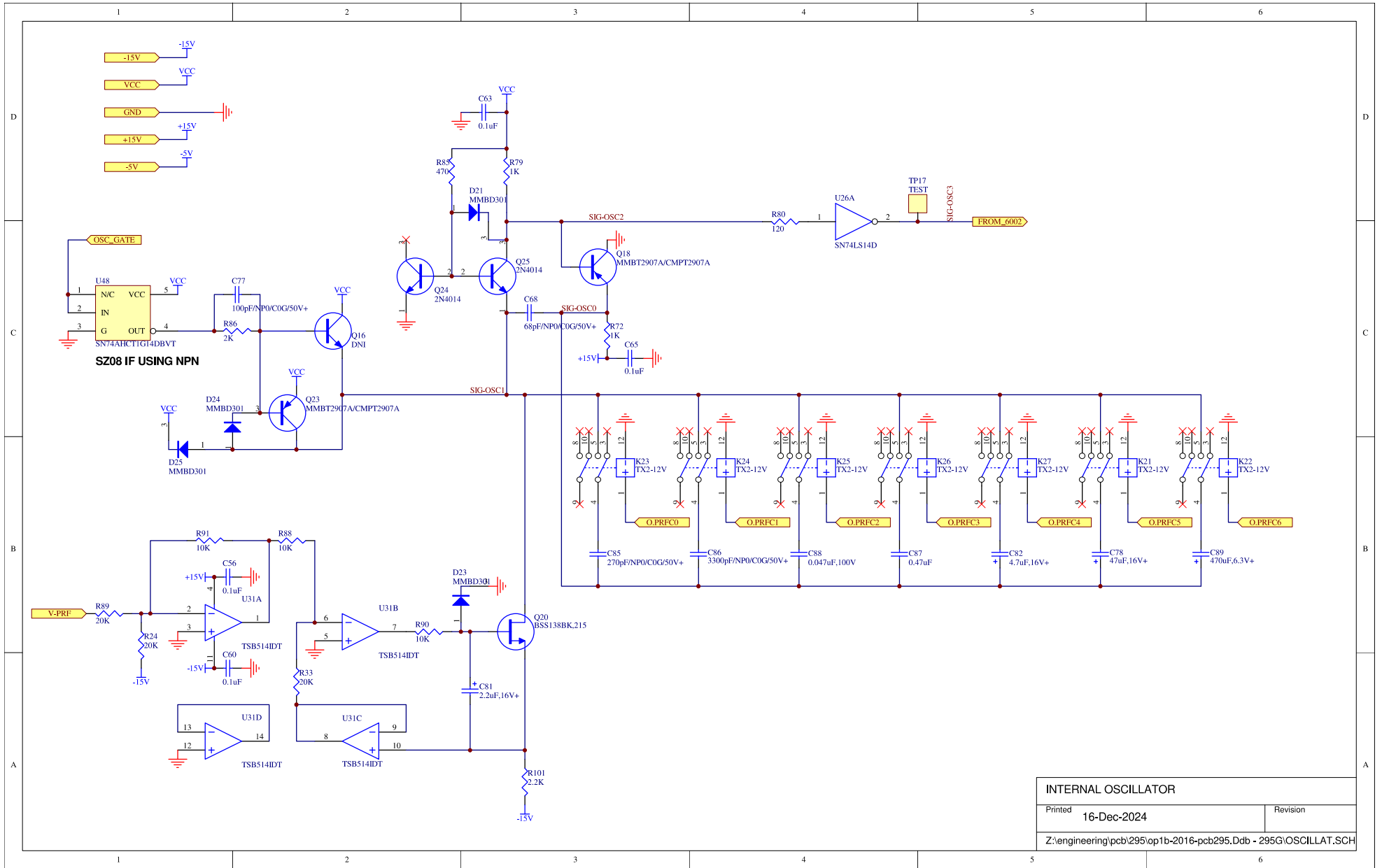

# PCB 295G - MAIN CONTROL BOARD, 9 OF 13, TTL OUTPUTS

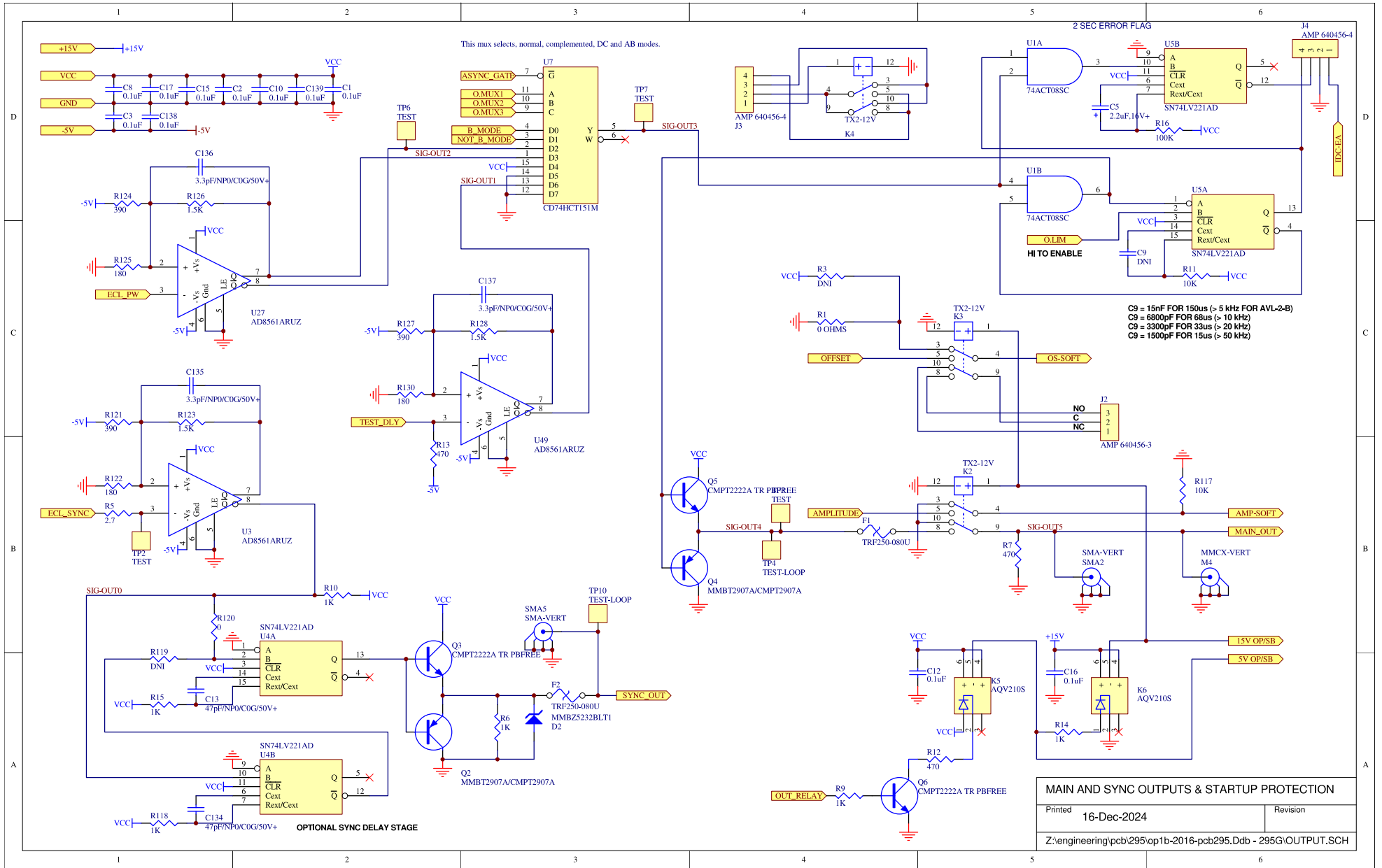

# PCB 295G - MAIN CONTROL BOARD, 10 OF 13, DELAY CIRCUITS

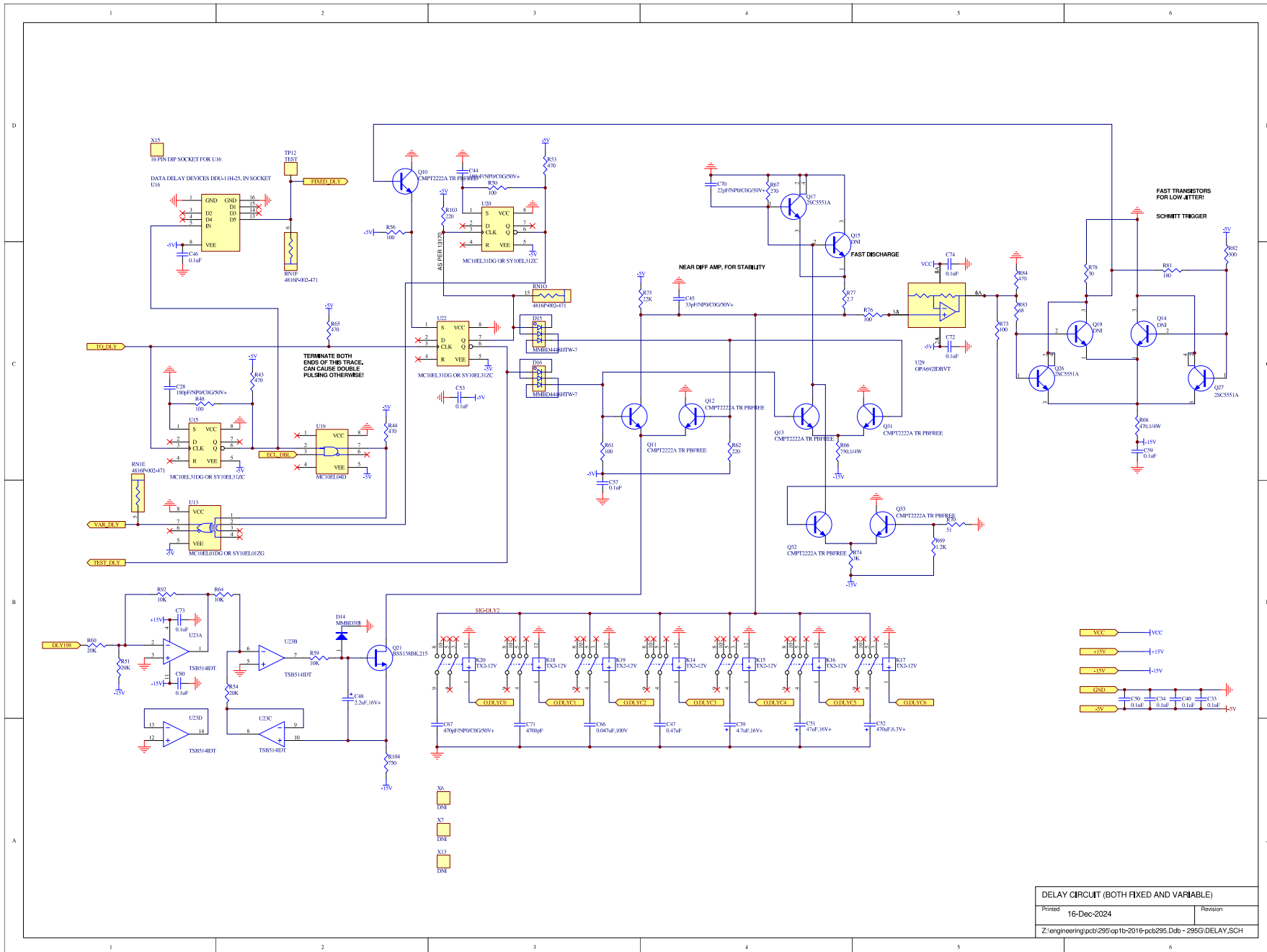

| DELAY CIRCUIT (BOTH FIXED AND VARIABLE)                       |          |
|---|----------|
| Printed   | Revision |
| 16-Dec-2024   |          |
| Z:\engineering\pcb\295\opt16-2016-pcb295.Dwg - 295G.DELAY.SCH |          |



# PCB 295G - MAIN CONTROL BOARD, 12 OF 13, TRIGGER SELECT

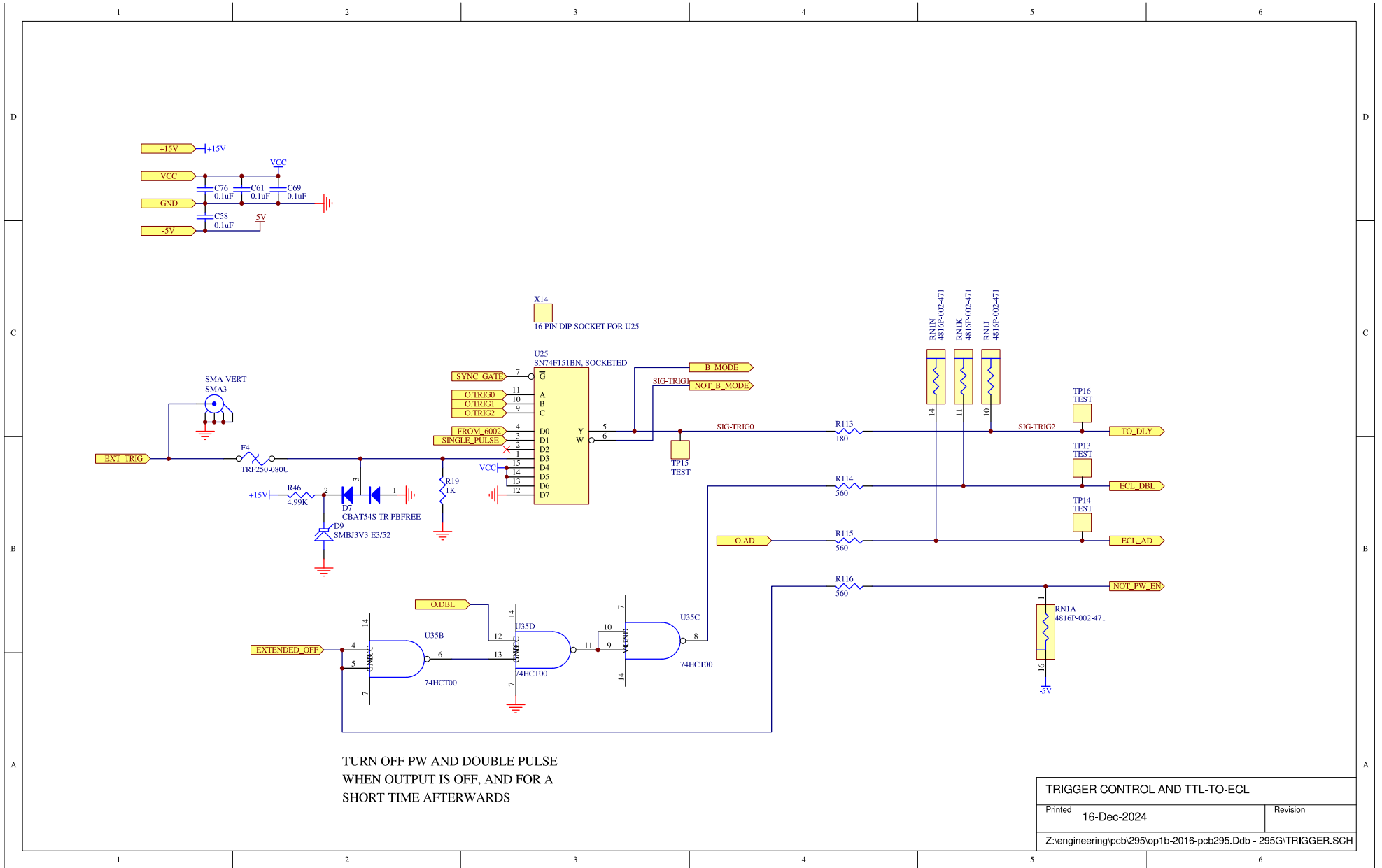

# PCB 295G - MAIN CONTROL BOARD, 13 OF 13, SHIFT REGISTERS

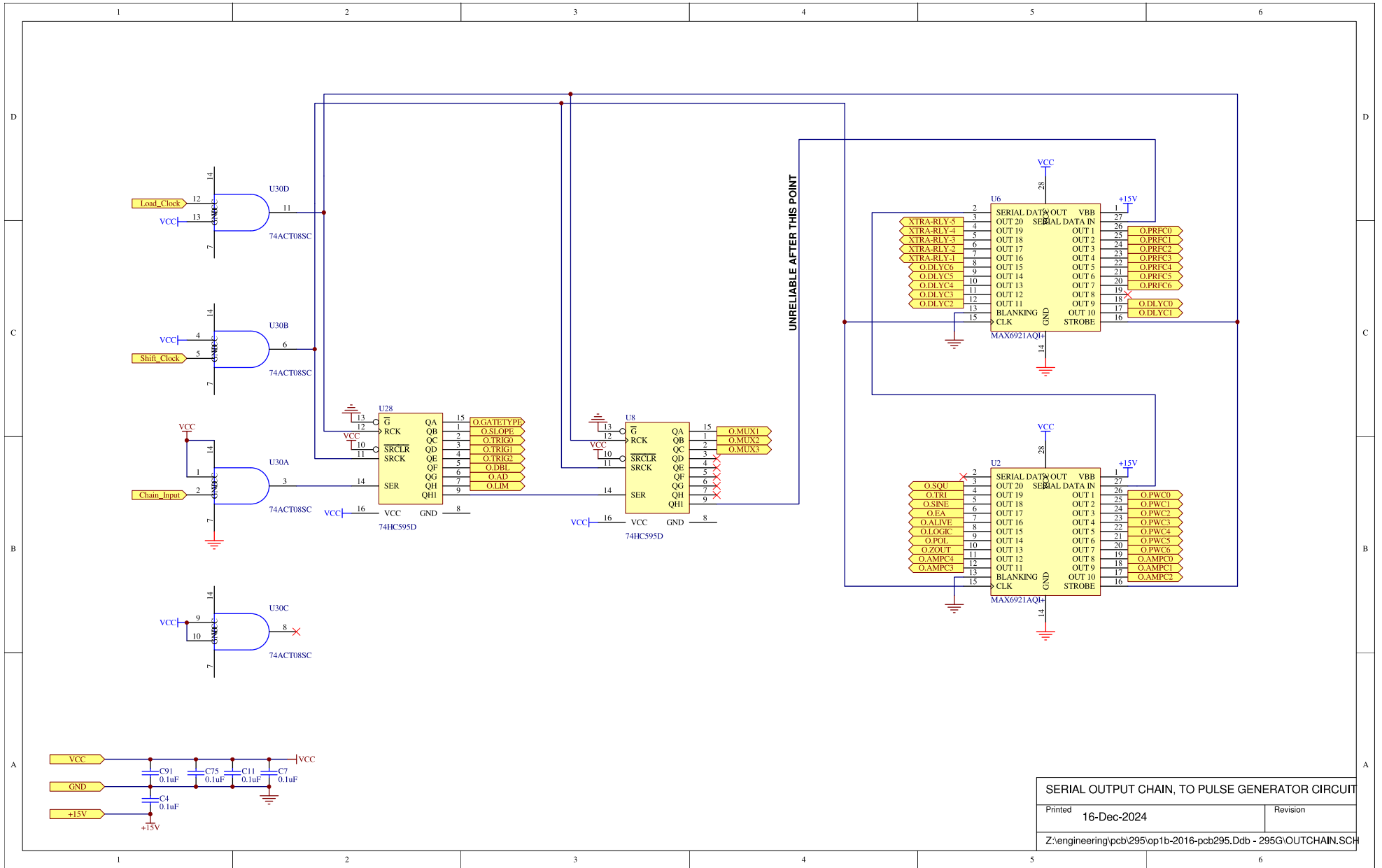



PERFORMANCE CHECK SHEET