



AVTECH ELECTROSYSTEMS LTD.

NANOSECOND WAVEFORM ELECTRONICS  
SINCE 1975

info@avtechpulse.com  
<http://www.avtechpulse.com/>

Tel: 888-670-8729 (USA & Canada)  
or +1-613-686-6675 (Worldwide)

BOX 5120, LCD MERIVALE  
OTTAWA, CANADA K2C3H5

## INSTRUCTIONS

MODEL AVR-E3A-B

100 VOLT, < 1.5 ns RISE TIME

HIGH PERFORMANCE PULSE GENERATOR

WITH IEEE 488.2 / RS-232 / ETHERNET CONTROL

SERIAL NUMBER: 14534

### WARRANTY

Avtech Electrosystems Ltd. warrants products of its manufacture to be free from defects in material and workmanship under conditions of normal use. If, within one year after delivery to the original owner, and after prepaid return by the original owner, this Avtech product is found to be defective, Avtech shall at its option repair or replace said defective item. This warranty does not apply to units which have been disassembled, modified or subjected to conditions exceeding the applicable specifications or ratings. This warranty is the extent of the obligation assumed by Avtech with respect to this product and no other warranty or guarantee is either expressed or implied.

### TECHNICAL SUPPORT

Phone: 888-670-8729 (USA & Canada)  
or +1-613-686-6675 (Worldwide)

E-mail: [info@avtechpulse.com](mailto:info@avtechpulse.com)  
World Wide Web: <http://www.avtechpulse.com>

## TABLE OF CONTENTS

<b>WARRANTY.....</b>	<b>2</b>
<b>TECHNICAL SUPPORT.....</b>	<b>2</b>
<b>TABLE OF CONTENTS.....</b>	<b>3</b>
<b>INTRODUCTION.....</b>	<b>6</b>
<b>SPECIFICATIONS.....</b>	<b>7</b>
<b>REGULATORY NOTES.....</b>	<b>8</b>
FCC PART 18.....	8
EC DECLARATION OF CONFORMITY.....	8
DIRECTIVE 2011/65/EU (RoHS).....	9
DIRECTIVE 2002/96/EC (WEEE).....	9
FIRMWARE LICENSING.....	10
<b>INSTALLATION.....</b>	<b>11</b>
VISUAL CHECK.....	11
POWER RATINGS.....	11
CONNECTION TO THE POWER SUPPLY.....	11
PROTECTION FROM ELECTRIC SHOCK.....	12
ENVIRONMENTAL CONDITIONS.....	13
LABVIEW DRIVERS.....	13
<b>FUSES.....</b>	<b>14</b>
AC FUSE REPLACEMENT.....	14
DC FUSE REPLACEMENT.....	15
FUSE RATINGS.....	15
<b>FRONT PANEL CONTROLS.....</b>	<b>17</b>
<b>REAR PANEL CONTROLS.....</b>	<b>19</b>
<b>GENERAL INFORMATION.....</b>	<b>21</b>
BASIC PULSE CONTROL.....	21
TRIGGER MODES.....	22
GATING MODES.....	23
<b>OPTIONAL FEATURES.....</b>	<b>24</b>
RACK MOUNTING, "-R5" OPTION.....	24
DC OFFSET, "-OS" OPTION.....	24
DC OFFSET, "-OT" OPTION.....	24
<b>PROTECTING YOUR INSTRUMENT.....</b>	<b>25</b>

TURN OFF INSTRUMENT WHEN NOT IN USE.....	25
DO NOT EXCEED 200 kHz.....	25
USE A 50Ω LOAD.....	25
<b>OPERATIONAL CHECK.....</b>	<b>26</b>
<b>PROGRAMMING YOUR PULSE GENERATOR.....</b>	<b>30</b>
KEY PROGRAMMING COMMANDS.....	30
ALL PROGRAMMING COMMANDS.....	31
<b>MECHANICAL INFORMATION.....</b>	<b>33</b>
TOP COVER REMOVAL.....	33
RACK MOUNTING.....	33
ELECTROMAGNETIC INTERFERENCE.....	33
<b>MAINTENANCE.....</b>	<b>34</b>
REGULAR MAINTENANCE.....	34
CLEANING.....	34
TRIGGER DAMAGE.....	34
<b>WIRING DIAGRAMS.....</b>	<b>35</b>
WIRING OF AC POWER.....	35
PCB 158R7 - LOW VOLTAGE POWER SUPPLY.....	36
PCB 235D - HIGH VOLTAGE DC POWER SUPPLY.....	37
PCB 284D - HIGH VOLTAGE DC POWER SUPPLY.....	38
PGA, 1 OF 4 - NARROW PULSE GENERATOR DRIVE CIRCUIT.....	39
PGA, 2 OF 4 - NARROW PULSE GENERATOR OUTPUT CIRCUIT.....	40
PGA, 3 OF 4 - AMPLITUDE PIN DIODE BIAS CONTROL OP AMPS.....	41
PGA, 4 OF 4 - PULSE WIDTH BIAS CONTROL OP AMPS.....	42
PGBC-P, 1 OF 3 - WIDE PULSE GENERATOR DRIVE CIRCUIT.....	43
PGBC-P, 2 OF 3 - WIDE PULSE GENERATOR OUTPUT CIRCUIT.....	44
PGBC-P, 3 OF 3 - AMPLITUDE CLAMP VOLTAGE BIAS CIRCUIT.....	45
PCB 335C - TRIGGER MULTIPLEXER.....	46
PCB 231A - DC OFFSET SOURCE.....	47
PCB 216F - RELAY DRIVER AND TWEAKING OP AMPS.....	48
PCB 104H - KEYPAD / DISPLAY BOARD.....	49
PCB 295E - MAIN CONTROL BOARD, 1 OF 13, TOP-LEVEL.....	50
PCB 295E - MAIN CONTROL BOARD, 2 OF 13, MICROCONTROLLER TOP-LEVEL.....	51
PCB 295E - MAIN CONTROL BOARD, 3 OF 13, EMBEDDED CONTROLLER.....	52
PCB 295E - MAIN CONTROL BOARD, 4 OF 13, GPIB INTERFACE.....	53

**PCB 295E - MAIN CONTROL BOARD, 5 OF 13, DACs.....54**  
**PCB 295E - MAIN CONTROL BOARD, 6 OF 13, TIMING TOP-LEVEL.....55**  
**PCB 295E - MAIN CONTROL BOARD, 7 OF 13, GATE CIRCUIT.....56**  
**PCB 295E - MAIN CONTROL BOARD, 8 OF 13, OSCILLATOR.....57**  
**PCB 295E - MAIN CONTROL BOARD, 9 OF 13, TTL OUTPUTS.....58**  
**PCB 295E - MAIN CONTROL BOARD, 10 OF 13, DELAY CIRCUITS.....59**  
**PCB 295E - MAIN CONTROL BOARD, 11 OF 13, PULSE WIDTH CIRCUIT.....60**  
**PCB 295E - MAIN CONTROL BOARD, 12 OF 13, TRIGGER SELECT.....61**  
**PCB 295E - MAIN CONTROL BOARD, 13 OF 13, SHIFT REGISTERS.....62**  
**MAIN WIRING.....63**  
**MAIN WIRING (-PN UNITS WITH -W2 OR -W3 OPTIONS).....64**  
***PERFORMANCE CHECKSHEET.....65***

Manual Reference: /fileserver1/officefiles/instructword/avr-e/AVR-E3A-B,sn14534.odt.  
Last modified January 27, 2025.  
Copyright © 2025 Avtech Electrosystems Ltd, All Rights Reserved.

## INTRODUCTION

The AVR-E3A-B is a high performance, GPIB/RS232/Ethernet-equipped instrument capable of generating 100V into 50 $\Omega$  loads. The rise time is less than 1.5 ns, and the fall time is less than 2.5 ns. The maximum pulse repetition frequency is 200 kHz.

On standard models, the output pulse width is variable from 15 ns to 500 ns.

Models with the -W1 option have an output pulse width variable from 3 ns to 500 ns.

Models with the -W2 option have an output pulse width variable from 15 ns to 5  $\mu$ s.

Models with the -W3 option have an output pulse width variable from 3 ns to 5  $\mu$ s.

Instruments with the -P model suffix can generate up to +100V, whereas instruments with the -N model suffix can generate up to -100V. Instruments with the -PN suffix can generate both polarities.

A 50 Ohm load is *required* for proper operation. The output stage may be damaged if the output is not terminated into a 50 $\Omega$  load.

The AVR-E3A-B is a highly flexible instrument. Aside from the internal trigger source, it can also be triggered or gated by external TTL-level signals. A front-panel pushbutton or a computer command can also be used to trigger the instrument.

The AVR-E3A-B features front panel keyboard and adjust knob control of the output pulse parameters along with a four line by 40-character backlit LCD display of the output amplitude, pulse width, pulse repetition frequency, and delay. The instrument includes memory to store up to four complete instrument setups. The operator may use the front panel or the computer interface to store a complete "snapshot" of all key instrument settings, and recall this setup at a later time.

This instrument is intended for use in research, development, test and calibration laboratories by qualified personnel.

## SPECIFICATIONS

Model <sup>1</sup> :	AVR-E3A-B
Maximum amplitude <sup>2</sup> :	100V
Rise time (20%-80%):	≤ 1.5 ns
Fall time (80%-20%):	≤ 2.5 ns
Pulse width (FWHM):	standard: 15 ns - 500 ns -W1 option: 3 ns - 500 ns -W2 option: 15 ns - 5 us -W3 option: 3 ns - 5 us
Maximum PRF (subject to duty cycle limit):	200 kHz
Maximum duty cycle:	5%
Required load <sup>5</sup> :	50Ω (±10%)
Polarity:	Positive or negative or both (specify <sup>3</sup> ).
DC offset or bias insertion:	Option available <sup>4</sup> . Apply required DC offset or bias in the range of ± 25 Volts, (250 mA max) to back panel solder terminals.
Trigger modes:	Internal trigger, external trigger (TTL level pulse, > 10 ns, 1 kΩ input impedance), front-panel "Single Pulse" pushbutton, or single pulse trigger via computer command.
Variable delay (Sync to main out):	0 to 1.0 seconds, for all trigger modes (including external trigger).
Propagation delay:	≤ 200 ns (Ext trig in to pulse out)
Jitter:	± 35ps ± 0.015% of sync delay (Ext trig in to pulse out)
Sync output:	> +3 Volts, > 50 ns, will drive 50 Ohm loads
Gate input:	Synchronous or asynchronous, active high or low, switchable. Suppresses triggering when active.
Connectors:	Out: SMA, Other: BNC
Power requirements:	100 - 240 Volts, 50 - 60 Hz
GPIB and RS-232 control <sup>1</sup> :	Standard on -B units.
LabView drivers:	Check <a href="http://www.avtechpulse.com/labview">http://www.avtechpulse.com/labview</a> for availability and downloads
Ethernet port, for remote control using VXI-11.3, ssh, telnet, & web:	Included. Recommended as a modern alternative to GPIB / RS-232. See <a href="http://www.avtechpulse.com/options/vxi">http://www.avtechpulse.com/options/vxi</a> for details.
Settings resolution:	The resolution of the timing parameters (pulse width, delay, period) varies, but is always better than 0.15% of ( set value  + 20 ns). The amplitude resolution is < 0.1% of the maximum amplitude.
Settings accuracy, after 10 minute warm-up:	Amplitude: Typically ± (3% of setting) ± (2% of maximum). Delay, Period: Typically ± (3% of setting) ± (5 ns) Pulse width: Typically ± (3% of setting) ± (2 ns), at maximum amplitude. As the amplitude is reduced, the pulse width may shift ± 5 ns. For high-accuracy applications requiring traceable calibration, verify the output with a calibrated oscilloscope <sup>6</sup> .
Dimensions (H x W x D):	100 mm x 430 mm x 375 mm (3.9" x 17" x 14.8")
Chassis material:	cast aluminum frame and handles, blue vinyl on aluminum cover plates
Temperature range:	+5°C to +40°C

- 1) -B suffix indicates IEEE-488.2 GPIB and RS-232 control of amplitude, pulse width, PRF and delay (see <http://www.avtechpulse.com/gpib>).
- 2) For operation at amplitudes of less than 10% of full-scale, best results will be obtained by setting the amplitude near full-scale and using external attenuators on the output.
- 3) Indicate desired polarity by suffixing model number with -P or -N (i.e. positive or negative) or -PN for dual polarity option.
- 4) The -OS option adds an internal bias tee circuit to the output, allowing an externally-generated DC offset (±25V/250mA max) to be added the output signal. The -OT option includes the -OS function, and adds the ability to generate a ±5V/100mA offset internally (controlled from the front panel, or by computer command).
- 5) A 50Ω load is required. Other loads may damage the instrument. Consult Avtech ([info@avtechpulse.com](mailto:info@avtechpulse.com)) if you need to drive other load impedances.
- 6) These instruments are provided with a basic calibration checksheet, showing a selection of measured output parameters. These measurements are performed with equipment that is calibrated on a regular basis by a third-party ISO/IEC 17025:2005 accredited calibration laboratory. However, Avtech itself does not claim any accreditation. For applications requiring traceable performance, use a calibrated measurement system rather than relying on the accuracy of the pulse generator settings.

## REGULATORY NOTES

### FCC PART 18

This device complies with part 18 of the FCC rules for non-consumer industrial, scientific and medical (ISM) equipment.

This instrument is enclosed in a rugged metal chassis and uses a filtered power entry module (where applicable). The main output signal is provided on a shielded connector that is intended to be used with shielded coaxial cabling and a shielded load. Under these conditions, the interference potential of this instrument is low.

If interference is observed, check that appropriate well-shielded cabling is used on the output connectors. Contact Avtech ([info@avtechpulse.com](mailto:info@avtechpulse.com)) for advice if you are unsure of the most appropriate cabling. Also, check that your load is adequately shielded. It may be necessary to enclose the load in a metal enclosure.

If any of the connectors on the instrument are unused, they should be covered with shielded metal “dust caps” to reduce the interference potential.

This instrument does not normally require regular maintenance to minimize interference potential. However, if loose hardware or connectors are noted, they should be tightened. Contact Avtech ([info@avtechpulse.com](mailto:info@avtechpulse.com)) if you require assistance.

### EC DECLARATION OF CONFORMITY



We                    Avtech Electrosystems Ltd.  
                          P.O. Box 5120, LCD Merivale  
                          Ottawa, Ontario  
                          Canada K2C 3H5

declare that this pulse generator meets the intent of Directive 2014/30/EU for Electromagnetic Compatibility. Compliance pertains to the following specifications as listed in the official Journal of the European Communities:

EN 50081-1 Emission

EN 50082-1 Immunity



and that this pulse generator meets the intent of the Low Voltage Directive 2014/35/EU. Compliance pertains to the following specifications as listed in the official Journal of the European Communities:

EN 61010-1:2010+A1:2019, Safety requirements for electrical equipment for measurement, control, and laboratory use

DIRECTIVE 2011/65/EU (RoHS)

We Avtech Electrosystems Ltd.  
P.O. Box 5120, LCD Merivale  
Ottawa, Ontario  
Canada K2C 3H5

declare that, to the best of our knowledge, all electrical and electronic equipment (EEE) sold by the company are in compliance with Directive 2011/65/EU of the European Parliament and of the Council of 8 June 2011 on the restriction of the use of certain hazardous substances in electrical and electronic equipment (also known as “RoHS Recast”). In addition, this declaration of conformity is issued under the sole responsibility of Avtech Electrosystems Ltd. Specifically, products manufactured do not contain the substances listed in the table below in concentrations greater than the listed maximum value.

<i>Material/Substance</i>	<i>Threshold level</i>
Lead (Pb)	< 1000 ppm (0.1% by mass)
Mercury (Hg)	< 1000 ppm (0.1% by mass)
Hexavalent Chromium (Cr6+)	< 1000 ppm (0.1% by mass)
Polybrominated Biphenyls (PBB)	< 1000 ppm (0.1% by mass)
Polybrominated Diphenyl ethers (PBDE)	< 1000 ppm (0.1% by mass)
Cadmium (Cd)	< 100 ppm (0.01% by mass)
Bis(2-ethylhexyl) phthalate (DEHP)	< 1000 ppm (0.1% by mass)
Butyl benzyl phthalate (BBP)	< 1000 ppm (0.1% by mass)
Dibutyl phthalate (DBP)	< 1000 ppm (0.1% by mass)
Diisobutyl phthalate (DIBP)	< 1000 ppm (0.1% by mass)

DIRECTIVE 2002/96/EC (WEEE)

European customers who have purchased this equipment directly from Avtech will have completed a “WEEE Responsibility Agreement” form, accepting responsibility for WEEE

compliance (as mandated in Directive 2002/96/EC of the European Union and local laws) on behalf of the customer, as provided for under Article 9 of Directive 2002/96/EC.

Customers who have purchased Avtech equipment through local representatives should consult with the representative to determine who has responsibility for WEEE compliance. Normally, such responsibilities will lie with the representative, unless other arrangements (under Article 9) have been made.

Requirements for WEEE compliance may include registration of products with local governments, reporting of recycling activities to local governments, and financing of recycling activities.

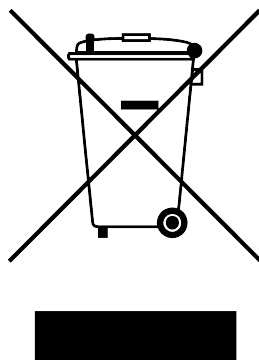

## FIRMWARE LICENSING

This instrument uses open-source software internally, and is built on a Fedora Linux operating system.

Some of this software requires that the source code be made available to the user as a condition of its licensing. The source code for programs used by Fedora is freely available at <https://src.fedoraproject.org/>.

The source code for modifications implemented by Avtech, and for Avtech-specific programs, is available at <https://www.avtechpulse.com/cgit/Instrument.git/>.

## INSTALLATION

### VISUAL CHECK

After unpacking the instrument, examine to ensure that it has not been damaged in shipment. Visually inspect all connectors, knobs, liquid crystal displays (LCDs), and the handles. Confirm that a power cord, a GPIB cable, and two instrumentation manuals (this manual and the “Programming Manual for -B Instruments”) are with the instrument. If the instrument has been damaged, file a claim immediately with the company that transported the instrument.

### POWER RATINGS

This instrument is intended to operate from 100 - 240 V, 50 - 60 Hz.

The maximum power consumption is 57 Watts for standard models, and 90 Watts for models with the -W1, -W2 or -W3 options. Please see the “FUSES” section for information about the appropriate AC and DC fuses.

This instrument is an “Installation Category II” instrument, intended for operation from a normal single-phase supply.

### CONNECTION TO THE POWER SUPPLY

An IEC-320 three-pronged recessed male socket is provided on the back panel for AC power connection to the instrument. One end of the detachable power cord that is supplied with the instrument plugs into this socket. The other end of the detachable power cord plugs into the local mains supply. Use only the cable supplied with the instrument. The mains supply must be earthed, and the cord used to connect the instrument to the mains supply must provide an earth connection. (The supplied cord does this.)

 Warning: Failure to use a grounded outlet may result in injury or death due to electric shock. This product uses a power cord with a ground connection. It must be connected to a properly grounded outlet. The instrument chassis is connected to the ground wire in the power cord.

The table below describes the power cord that is normally supplied with this instrument, depending on the destination region:

Destination Region	Description	Option	Manufacturer	Part Number
United Kingdom, Hong Kong, Singapore, Malaysia	BS 1363, 230V, 50 Hz	-AC00	Qualtek	370001-E01
Australia, New Zealand	AS 3112:2000, 230-240V, 50 Hz	-AC01	Qualtek	374003-A01
Continental Europe, Korea, Indonesia, Russia	European CEE 7/7 "Schuko" 230V, 50 Hz	-AC02	Qualtek	364002-D01
North America, Taiwan	NEMA 5-15, 120V, 60 Hz	-AC03	Qualtek	312007-01
Switzerland	SEV 1011, 230V, 50 Hz	-AC06	Qualtek	378001-E01
South Africa, India	SABS 164-1, 220-250V, 50 Hz	-AC17	Volex	2131H 10 C3
Japan	JIS 8303, 100V, 50-60 Hz	-AC18	Qualtek	397002-01
Israel	SI 32, 220V, 50 Hz	-AC19	Qualtek	398001-01
China	GB 1002-1 / 2099-1, 220V, 50 Hz	-AC22	Qualtek	399012-01

## PROTECTION FROM ELECTRIC SHOCK

 Operators of this instrument must be protected from electric shock at all times. The owner must ensure that operators are prevented access and/or are insulated from every connection point. In some cases, connections must be exposed to potential human contact. Operators must be trained to protect themselves from the risk of electric shock. This instrument is intended for use by qualified personnel who recognize shock hazards and are familiar with safety precautions required to avoid possibly injury. In particular, operators should:

1. Keep exposed high-voltage wiring to an absolute minimum.
2. Wherever possible, use shielded connectors and cabling.
3. Connect and disconnect loads and cables only when the instrument is turned off.
4. Keep in mind that all cables, connectors, oscilloscope probes, and loads must have an appropriate voltage rating.
5. Do not attempt any repairs on the instrument, beyond the fuse replacement procedures described in this manual. Contact Avtech technical support (see page 2 for contact information) if the instrument requires servicing. Service is to be performed solely by qualified service personnel.

## ENVIRONMENTAL CONDITIONS

This instrument is intended for use under the following conditions:

1. indoor use;
2. altitude up to 2 000 m;
3. temperature 5 °C to 40 °C;
4. maximum relative humidity 80 % for temperatures up to 31 °C decreasing linearly to 50 % relative humidity at 40 °C;
5. Mains supply voltage fluctuations up to  $\pm 10$  % of the nominal voltage;
6. no pollution or only dry, non-conductive pollution.

## LABVIEW DRIVERS

A LabVIEW driver for this instrument is available for download on the Avtech web site, at <http://www.avtechpulse.com/labview>. A copy is also available in National Instruments' Instrument Driver Library at <http://www.natinst.com/>.

## FUSES

This instrument contains four fuses. All are accessible from the rear-panel. Two protect the AC prime power input, and two protect the internal DC power supplies. The locations of the fuses on the rear panel are shown in the figure below:

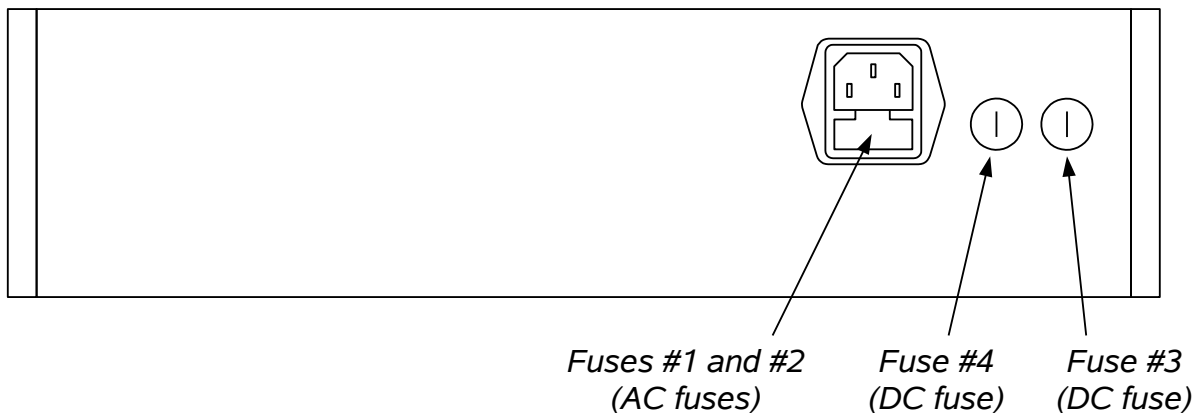

### AC FUSE REPLACEMENT

To physically access the AC fuses, the power cord must be detached from the rear panel of the instrument. The fuse drawer may then be extracted using a small flat-head screwdriver, as shown below:

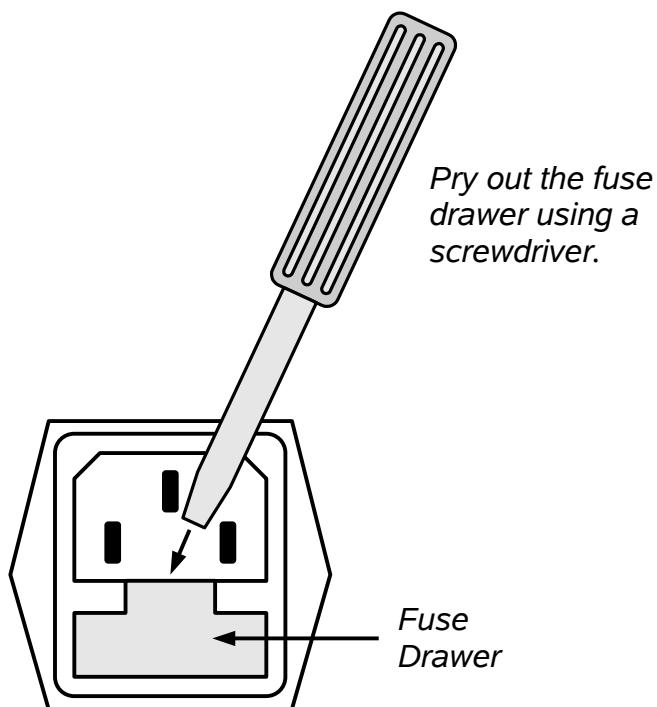

## DC FUSE REPLACEMENT

The DC fuses may be replaced by inserting the tip of a flat-head screwdriver into the fuse holder slot, and rotating the slot counter-clockwise. The fuse and its carrier will then pop out.

## FUSE RATINGS

The following table lists the required fuses for standard models:

Fuses	Nominal Mains Voltage	Rating	Case Size	Recommended Replacement Part	
				Littelfuse Part Number	Digi-Key Stock Number
#1, #2 (AC)	100-240V	0.5A, 250V, Time-Delay	5×20 mm	0218.500HXP	F2416-ND
#3 (DC)	N/A	1.6A, 250V, Time-Delay	5×20 mm	021801.6HXP	F2424-ND
#4 (DC)	N/A	0.8A, 250V, Time-Delay	5×20 mm	0218.800HXP	F2418-ND

Models with the -W1 option require these fuses:

Fuses	Nominal Mains Voltage	Rating	Case Size	Recommended Replacement Part	
				Littelfuse Part Number	Digi-Key Stock Number
#1, #2 (AC)	115 V	0.8A, 250V, Time-Delay	5×20 mm	0218.800HXP	F2418-ND
	230 V	0.5A, 250V, Time-Delay	5×20 mm	0218.500HXP	F2416-ND
#3 (DC)	N/A	1.6A, 250V, Time-Delay	5×20 mm	021801.6HXP	F2424-ND
#4 (DC)	N/A	1.0A, 250V, Time-Delay	5×20 mm	0218001.HXP	F2419-ND

Models with the -W2 option (-P or -N) require these fuses:

Fuses	Nominal Mains Voltage	Rating	Case Size	Recommended Replacement Part	
				Littelfuse Part Number	Digi-Key Stock Number
#1, #2 (AC)	100-240V	0.5A, 250V, Time-Delay	5×20 mm	0218.500HXP	F2416-ND
#3 (DC)	N/A	1.6A, 250V, Time-Delay	5×20 mm	021801.6HXP	F2424-ND
#4 (DC)	N/A	1.6A, 250V, Time-Delay	5×20 mm	021801.6HXP	F2424-ND

Models with the -W2-PN or -W3 (all polarities) options require these fuses:

Fuses	Nominal Mains Voltage	Rating	Case Size	Recommended Replacement Part	
				Littelfuse Part Number	Digi-Key Stock Number
#1, #2 (AC)	115 V	0.8A, 250V, Time-Delay	5×20 mm	0218.800HXP	F2418-ND
	230 V	0.5A, 250V, Time-Delay	5×20 mm	0218.500HXP	F2416-ND
#3 (DC)	N/A	2.0A, 250V, Time-Delay	5×20 mm	0218002.HXP	F2420-ND
#4 (DC)	N/A	1.6A, 250V, Time-Delay	5×20 mm	021801.6HXP	F2424-ND

The recommended fuse manufacturer is Littelfuse (<http://www.littelfuse.com>).

Replacement fuses may be easily obtained from Digi-Key (<http://www.digikey.com>) and other distributors.



## FRONT PANEL CONTROLS

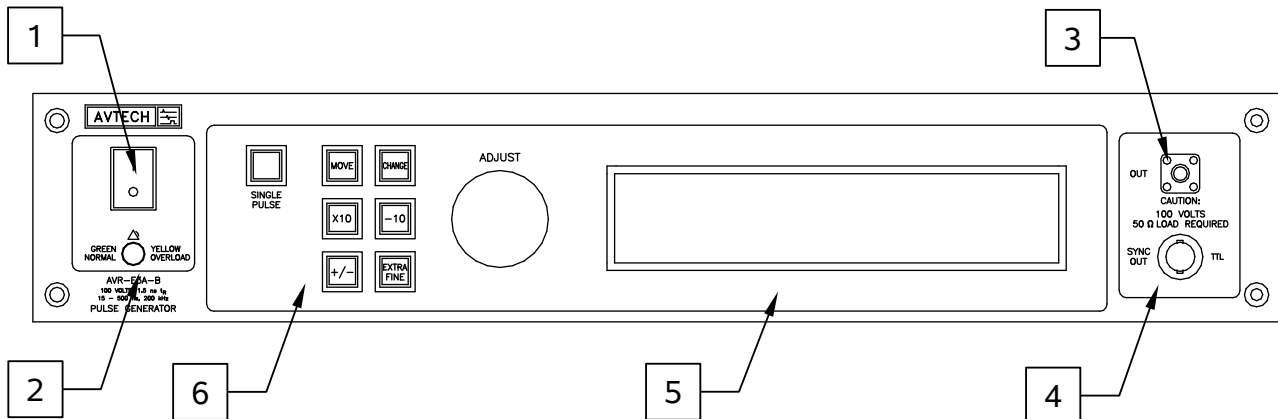

1. POWER Switch. This is the main power switch. When turning the instrument on, there is normally a delay of 10 seconds before anything is shown on the main display, as the internal operating system boots up.
2. OVERLOAD Indicator. When the instrument is powered, this indicator is normally green, indicating normal operation. If this indicator is yellow, an internal automatic overload protection circuit has been tripped. If the unit is overloaded (by operating at an exceedingly high duty cycle or by operating into a very low impedance), the protective circuit will disable the output of the instrument and turn the indicator light yellow. The light will stay yellow (i.e. output disabled) for about 5 seconds after which the instrument will attempt to re-enable the output (i.e. light green) for about 1 second. If the overload condition persists, the output will be disabled again (i.e. light yellow) for another 5 seconds. If the overload condition has been removed, the instrument will resume normal operation.

This overload indicator may flash yellow briefly at start-up. This is not a cause for concern.

3. OUT CONNECTOR. This SMA connector provides the main output signal, into load impedances of  $50\Omega$ .
4. SYNC OUT. This connector supplies a SYNC output that can be used to trigger other equipment, particularly oscilloscopes. This signal leads (or lags) the main output by a duration set by the "DELAY" controls and has an approximate amplitude of +3 Volts to  $R_L > 50\Omega$  with a pulse width of approximately 100 ns.
5. LIQUID CRYSTAL DISPLAY (LCD). This LCD is used in conjunction with the keypad to change the instrument settings. Normally, the main menu is displayed, which lists the key adjustable parameters and their current values. The "Programming Manual for -B Instruments" describes the menus and submenus in detail.

6. KEYPAD.

Control Name	Function
MOVE	This moves the arrow pointer on the display.
CHANGE	This is used to enter the submenu, or to select the operating mode, pointed to by the arrow pointer.
×10	If one of the adjustable numeric parameters is displayed, this increases the setting by a factor of ten.
÷10	If one of the adjustable numeric parameters is displayed, this decreases the setting by a factor of ten.
+/-	If one of the adjustable numeric parameters is displayed, and this parameter can be both positive or negative, this changes the sign of the parameter.
EXTRA FINE	This changes the step size of the ADJUST knob. In the extra-fine mode, the step size is twenty times finer than in the normal mode. This button switches between the two step sizes.
ADJUST	This large knob adjusts the value of any displayed numeric adjustable values, such as frequency, pulse width, etc. The adjust step size is set by the "EXTRA FINE" button.  When the main menu is displayed, this knob can be used to move the arrow pointer.

## REAR PANEL CONTROLS

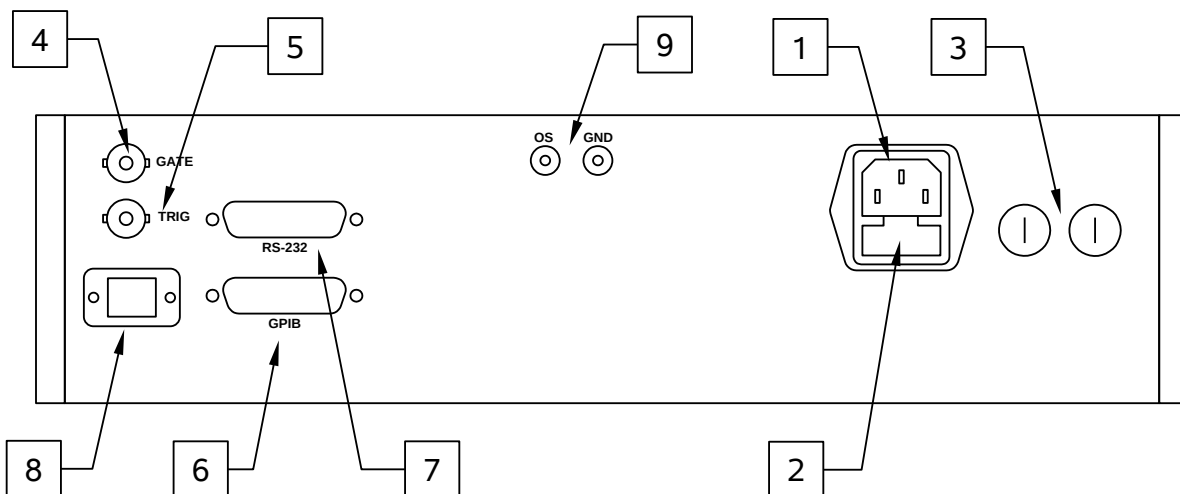

*Note: some connectors may be in different positions than shown above, depending on the exact combination of options ordered.*

1. AC POWER INPUT. An IEC-320 C14 three-pronged recessed male socket is provided on the back panel for AC power connection to the instrument. One end of the detachable power cord that is supplied with the instrument plugs into this socket.
2. AC FUSE DRAWER. The two fuses that protect the AC input are located in this drawer. Please see the “FUSES” section of this manual for more information.
3. DC FUSES. These two fuses protect the internal DC power supplies. Please see the “FUSES” sections of this manual for more information.
4. GATE. This TTL-level (0 and +5V) logic input can be used to gate the triggering of the instrument. This input can be either active high or active low, depending on the front panel settings or programming commands. (The instrument triggers normally when this input is unconnected). When set to active high mode, this input is pulled-down to ground by a 1 k $\Omega$  resistor. When set to active low mode, this input is pulled-up to +5V by a 1 k $\Omega$  resistor.
5. TRIG. This TTL-level (0 and +5V) logic input can be used to trigger the instrument, if the instrument is set to triggering externally. The instrument triggers on the rising edge of this input. The input impedance of this input is 1 k $\Omega$ . (Depending on the length of cable attached to this input, and the source driving it, it may be desirable to add a coaxial 50 Ohm terminator to this input to provide a proper transmission line termination. The Pasternack ([www.pasternack.com](http://www.pasternack.com)) PE6008-50 BNC feed-thru 50 Ohm terminator is suggested for this purpose.)

6. GPIB Connector. A standard GPIB cable can be attached to this connector to allow the instrument to be computer-controlled. See the “Programming Manual for -B Instruments” for more details on GPIB control.
7. RS-232 Connector. A standard serial cable with a 25-pin male connector can be attached to this connector to allow the instrument to be computer-controlled. A user name (“admin”) and a password (“default”, as shipped from the factory) are required when logging into a serial terminal session. The internal controller attempts to auto-sense the parity setting. It may be necessary to send a few return characters before attempting a login in order to provide enough data to allow this auto-sensing to work. (A standard Linux “agetty” process is used to implement serial control internally.) See the “Programming Manual for -B Instruments” for more details on RS-232 control.
8. Network Connector. This Ethernet connector allows the instrument to be remotely controlled using the VXI-11.3, ssh (secure shell), telnet, and http (web) protocols. See the “Programming Manual for -B Instruments” for more details.
9. OS Connector. (Optional feature. Present on units with the -OS and -OT options only). This connector allows an externally generated DC offset to be added to the output. The desired DC offset is applied to this connector, which is connected to the output centre conductor through a high-quality RF inductor. Do not exceed  $\pm 50\text{V}$ , 250 mA. For units with the -OS option, this input is always active. For units with the -OT option, the DC offset is generated internally by default, unless the “volt:low ext” command is sent, or the external mode is selected from the front panel offset menu – in which case, the externally-generated DC bias is applied to this input.

## GENERAL INFORMATION

### BASIC PULSE CONTROL

This instrument can be triggered by its own internal clock or by an external TTL trigger signal. In either case, two output channels respond to the trigger: OUT and SYNC.

- OUT. This is the main output. The maximum output voltage is 100V.
- SYNC. The SYNC pulse is a fixed-width TTL-level reference pulse used to trigger oscilloscopes or other measurement systems. When the delay is set to a positive value the SYNC pulse precedes the OUT pulse. When the delay is set to a negative value the SYNC pulse follows the OUT pulse.

These pulses are illustrated below, assuming internal triggering and a positive delay. All waveforms are shown with positive amplitudes.

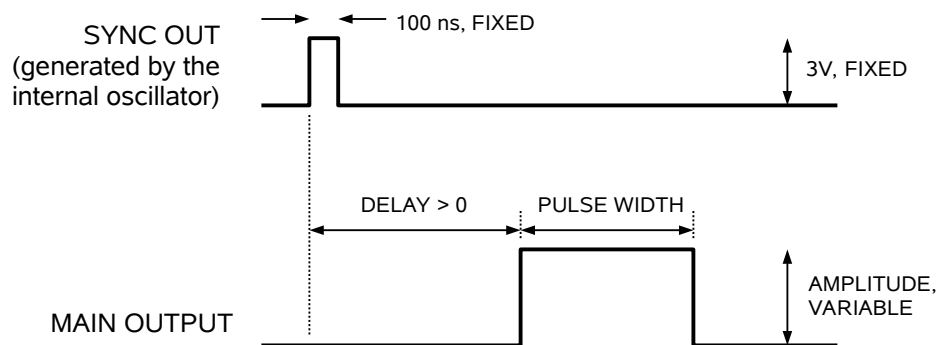

*Figure A*

If the delay is negative, the order of the SYNC and OUT pulses is reversed:

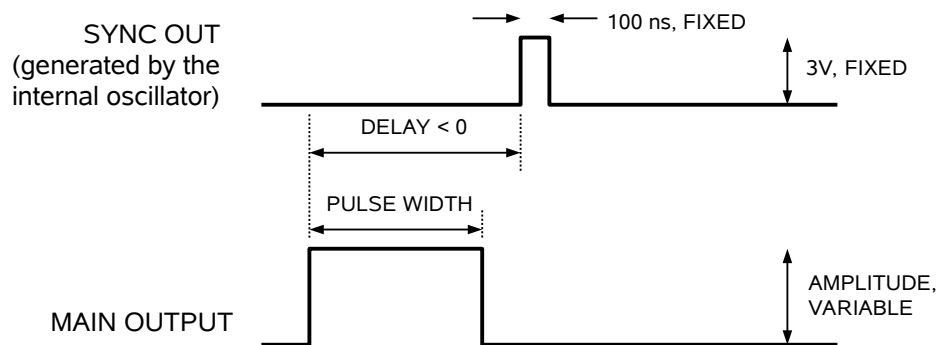

*Figure B*

The next figure illustrates the relationship between the signal when an external TTL-level trigger is used:

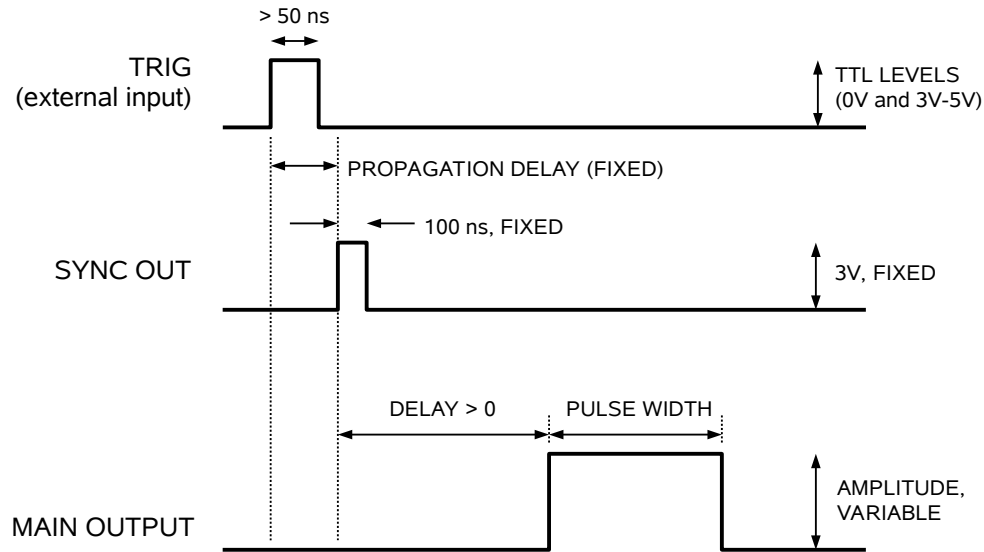

Figure C

As before, if the delay is negative, the order of the SYNC and OUT pulses is reversed.

In general, the delay, pulse width, and frequency (when in the internal mode), of the OUT pulse can be varied with front panel controls or via the GPIB or RS-232 computer interfaces.

### TRIGGER MODES

This instrument has four trigger modes:

- Internal Trigger: the instrument controls the trigger frequency, and generates the clock internally.
- External Trigger: the instrument is triggered by an external TTL-level clock on the back-panel TRIG connector.
- Manual Trigger: the instrument is triggered by the front-panel "SINGLE PULSE" pushbutton.
- Hold Trigger: the instrument is set to not trigger at all.

These modes can be selected using the front panel trigger menu, or by using the appropriate programming commands. (See the "Programming Manual for -B Instruments" for more details.)

## GATING MODES

Triggering can be suppressed by a TTL-level signal on the rear-panel GATE connector. The instrument can be set to stop triggering when this input high or low, using the front-panel gate menu or the appropriate programming commands. This input can also be set to act synchronously or asynchronously. When set to asynchronous mode, the GATE will disable the output immediately. Output pulses may be truncated. When set to synchronous mode, the output will complete the full pulse width if the output is high, and then stop triggering. No pulses are truncated in this mode.

## OPTIONAL FEATURES

### RACK MOUNTING, "-R5" OPTION

A rack mounting kit is available. The "-R5" rack mount kit may be installed after first removing the one Phillips screw on the side panel adjacent to the front handle.

### DC OFFSET, "-OS" OPTION

This option adds a bias tee circuit on the output, with a rear-panel "OS" connector. This connector allows an externally generated DC offset to be added to the output. The desired DC offset is applied to this connector, which is connected to the output centre conductor through a high-quality RF inductor. Do not exceed  $\pm 50V$ , 250 mA.

### DC OFFSET, "-OT" OPTION

This option adds a bias tee circuit on the output, and adds an internal 0 to  $\pm 5V$  DC bias source. The offset level can be set by the front-panel controls, or by computer commands. The internal DC source is active by default, unless the "volt:low ext" command is sent, or the external mode is selected from the front panel offset menu. In that case, the user must add the desired externally-generated DC offset to the rear-panel solder terminals ( $\pm 50$  Volts / 250 mA maximum).



## PROTECTING YOUR INSTRUMENT

### TURN OFF INSTRUMENT WHEN NOT IN USE

The lifetime of the switching elements in the pulse generator module is proportional to the running time of the instrument. For this reason the prime power to the instrument should be turned off when the instrument is not in use. In the case of failure, the switching elements are easily replaced following the procedure described in a following section.

### DO NOT EXCEED 200 kHz

The output stage may be damaged if triggered by an external signal at a pulse repetition frequency greater than 200 kHz.

### USE A 50Ω LOAD

A 50 Ohm load is *required* for proper operation. The output stage may be damaged if the output is not terminated into a 50Ω load.

## OPERATIONAL CHECK

This section describes a sequence to confirm the basic operation of the instrument. It should be performed after receiving the instrument. It is a useful learning exercise as well.

Before proceeding with this procedure, finish reading this instruction manual thoroughly. Then read the “Local Control” section of the “Programming Manual for -B Instruments” thoroughly. The “Local Control” section describes the front panel controls used in this operational check - in particular, the MOVE, CHANGE, and ADJUST controls.

A 50 Ohm load is *required* for proper operation. The output stage may be damaged if the output is not terminated into a 50Ω load.

The AVR-E3A-B output may be observed using either a high-speed sampling oscilloscope, or a slower real-time oscilloscope. To accurately observe these rising and falling edges, a sampling oscilloscope with a bandwidth of 2 GHz is required. However, if the rising and falling edges do not need to be accurately observed, it may be more convenient to use a real-time oscilloscope. The two basic test arrangements are outlined in the figures below:

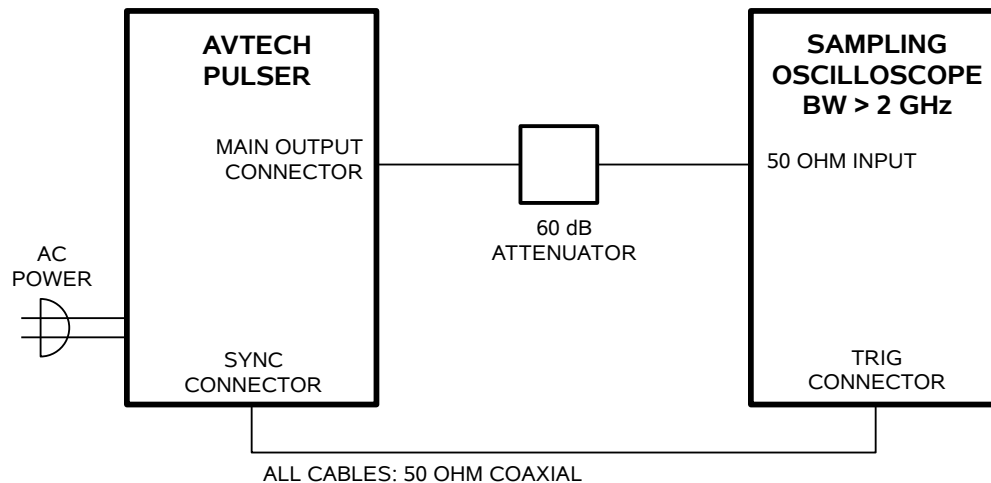

*BASIC TEST ARRANGEMENT, WITH A SAMPLING OSCILLOSCOPE*

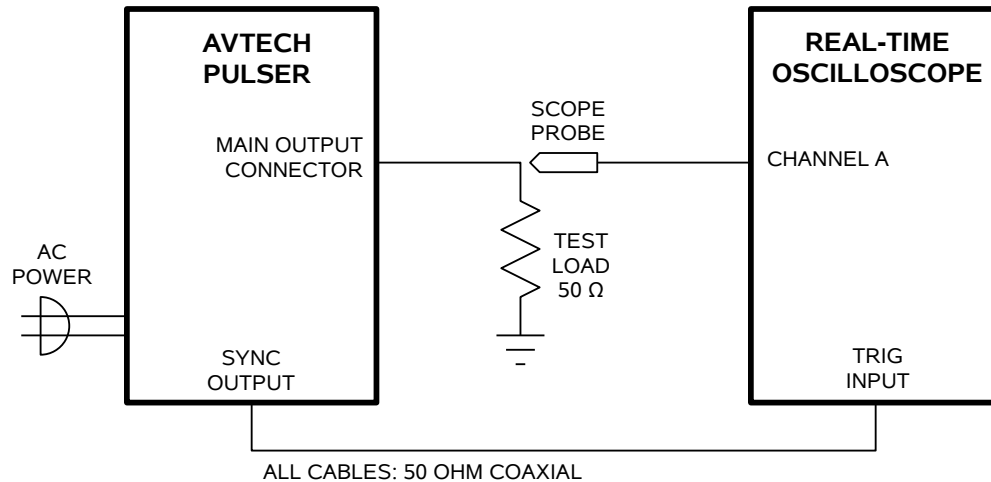

*BASIC TEST ARRANGEMENT, WITH A REAL-TIME OSCILLOSCOPE*

1. Connect the pulse generator to an oscilloscope using one of the two methods shown above. Note that:
  - a) If using a sampling oscilloscope, the use of 60 dB attenuator at the sampling scope vertical input channel will ensure a peak input signal to the sampling scope of less than 1 Volt.
  - b) If using a realtime oscilloscope, a 50 Ohm load must be used to terminate the output.
  - c) The SYNC output channel provides TTL level signals (approximately 0 and +3V). To avoid overdriving the TRIG input channel of some sampling oscilloscopes, a 20 dB attenuator should be placed at the input to the scope trigger channel.
  - d) The bandwidth capability of components and instruments used to display the pulse generator output signal (attenuators, cables, connectors, etc.) should exceed 2 GHz.
  - e) Set the oscilloscope to trigger externally with the vertical setting at 50 mV/div for sampling oscilloscopes, or 50 V/div for real-time scopes, and the horizontal setting at 20 ns/div.
2. Turn on the AVR-E3A-B. The main menu will appear on the LCD.
3. To set the AVR-E3A-B to trigger from the internal clock at a PRF of 10 kHz:

- a) The arrow pointer should be pointing at the frequency menu item. If it is not, press the MOVE button until it is.
  - b) Press the CHANGE button. The frequency submenu will appear. Rotate the ADJUST knob until the frequency is set at 10 kHz.
  - c) The arrow pointer should be pointing at the “Internal” choice. If it is not, press MOVE until it is.
  - d) Press CHANGE to return to the main menu.
4. To set the delay to 100 ns:
- a) Press the MOVE button until the arrow pointer is pointing at the delay menu item.
  - b) Press the CHANGE button. The delay submenu will appear. Rotate the ADJUST knob until the delay is set at 100 ns.
  - c) The arrow pointer should be pointing at the “Normal” choice. If it is not, press MOVE until it is.
  - d) Press CHANGE to return to the main menu.
5. To set the pulse width to 100 ns:
- a) Press the MOVE button until the arrow pointer is pointing at the pulse width menu item.
  - b) Press the CHANGE button. The pulse width submenu will appear. Rotate the ADJUST knob until the pulse width is set at 100 ns.
  - c) The arrow pointer should be pointing at the “Normal” choice. If it is not, press MOVE until it is.
  - d) Press CHANGE to return to the main menu.
6. At this point, nothing should appear on the oscilloscope.
7. To enable the output:
- a) Press the MOVE button until the arrow pointer is pointing at the output menu item.
  - b) Press the CHANGE button. The output submenu will appear.
  - c) Press MOVE until the arrow pointer is pointing at the “ON” choice.

- d) Press CHANGE to return to the main menu.
8. To change the output amplitude:
- a) Press the MOVE button until the arrow pointer is pointing at the amplitude menu item.
  - b) Press the CHANGE button. The amplitude submenu will appear. Rotate the ADJUST knob until the amplitude is set at +100V (or - 100V for "-N" models).
  - c) Observe the oscilloscope. You should see 100 ns wide, 100V pulses. If you do not, you may need to adjust the delay setting to a value more compatible with your sampling oscilloscope. Repeat step 4 if required. You may also need to adjust the sampling scope controls.
  - d) Rotate the ADJUST knob. The amplitude as seen on the oscilloscope should vary. Return it to 100V.
  - e) ("-PN" units only) Press the +/- button on the front panel. The amplitude as seen on the oscilloscope should flip polarity, to -100V.
  - f) Press CHANGE to return to the main menu.
9. Try varying the pulse width, by repeating step (5). As you rotate the ADJUST knob, the pulse width on the oscilloscope will change. It should agree with the displayed value.

This completes the operational check.

## PROGRAMMING YOUR PULSE GENERATOR

### KEY PROGRAMMING COMMANDS

The “Programming Manual for -B Instruments” describes in detail how to connect the pulse generator to your computer, and the programming commands themselves. A large number of commands are available; however, normally you will only need a few of these. Here is a basic sample sequence of commands that might be sent to the instrument after power-up:

```
*rst                (resets the instrument)
trigger:source internal (selects internal triggering)
frequency 1000 Hz   (sets the frequency to 1000 Hz)
pulse:width 50 ns  (sets the pulse width to 50 ns)
pulse:delay 20 ns  (sets the delay to 20 ns)
volt:ampl 50       (sets the amplitude to +50 V)
                   ("-N" units should use "volt:ampl -50")
volt:low -2        (sets the DC offset, for units with the -OT option)
output on          (turns on the output)
```

For triggering a single event, this sequence would be more appropriate:

```
*rst                (resets the instrument)
trigger:source hold (turns off all triggering)
pulse:width 50 ns  (sets the pulse width to 50 ns)
output on          (turns on the output)
volt:ampl 50       (sets the amplitude to +50 V)
                   ("-N" units should use "volt:ampl -50")
volt:low -2        (sets the DC offset, for units with the -OT option)
trigger:source immediate (generates a single non-repetitive trigger event)
trigger:source hold (turns off all triggering)
output off         (turns off the output)
```

To set the instrument to trigger from an external TTL signal applied to the rear-panel TRIG connector, use:

```
*rst                (resets the instrument)
trigger:source external (selects internal triggering)
pulse:width 50 ns  (sets the pulse width to 50 ns)
pulse:delay 1 us   (sets the delay to 1 us)
volt:ampl 50       (sets the amplitude to +50 V)
                   ("-N" units should use "volt:ampl -50")
volt:low -2        (sets the DC offset, for units with the -OT option)
output on          (turns on the output)
```

These commands will satisfy 90% of your programming needs.

## ALL PROGRAMMING COMMANDS

For more advanced programmers, a complete list of the available commands is given below. These commands are described in detail in the “Programming Manual for -B Instruments”. (Note: this manual also includes some commands that are not implemented in this instrument. They can be ignored.)

<u>Keyword</u>	<u>Parameter</u>	<u>Notes</u>
OUTPut:		
:[STATe]	<boolean value>	
:PROTection		
:TRIPped?		[query only]
[SOURce]:		
:FREQuency		
[:CW   FIXed]	<numeric value>	
[SOURce]:		
:PULSe		
:PERiod	<numeric value>	
:WIDTh	<numeric value>	
:DCYCLe	<numeric value>	
:HOLD	WIDTh   DCYCLe	
:DELay	<numeric value>	
:GATE		
:TYPE	ASYNc   SYNc	
:LEVel	HIgh   LOw	
[SOURce]:		
:VOLTage		
[:LEVel]		
[:IMMediate]		
[:AMPLitude]	<numeric value>   EXTeRnal	
:LOW	<numeric value>   EXTeRnal	[for -OT option only]
:PROTection		
:TRIPped?		[query only]
STATUS:		
:OPERation		
:[EVENt]?		[query only, always returns "0"]
:CONDition?		[query only, always returns "0"]
:ENABle	<numeric value>	[implemented but not useful]
:QUEStionable		
:[EVENt]?		[query only, always returns "0"]
:CONDition?		[query only, always returns "0"]
:ENABle	<numeric value>	[implemented but not useful]
SYSTEM:		
:COMMunicate		
:GPIB		
:ADDReSS	<numeric value>	
:SERial		
:CONTRol		
:RTS	ON   IBFull   RFR	
:[RECEive]		

:BAUD	1200   2400   4800   9600   19200   38400   57600   115200	
:ERRor		
:[NEXT]?		[query only]
:COUNT?		[query only]
:VERSion?		[query only]
TRIGger:		
:SOURce	INTernal   EXTernal   MANual   HOLD   IMMEDIATE	
*CLS		[no query form]
*ESE	<numeric value>	
*ESR?		[query only]
*IDN?		[query only]
*OPC		
*SAV	0   1   2   3	[no query form]
*RCL	0   1   2   3	[no query form]
*RST		[no query form]
*SRE	<numeric value>	
*STB?		[query only]
*TST?		[query only]
*WAI		[no query form]



## MECHANICAL INFORMATION

### TOP COVER REMOVAL

If necessary, the interior of the instrument may be accessed by removing the four Phillips screws on the top panel. With the four screws removed, the top cover may be slid back (and off).

 Always disconnect the power cord and allow the instrument to sit unpowered for 10 minutes before opening the instrument. This will allow any internal stored charge to discharge.

There are no user-adjustable internal circuits. For repairs other than fuse replacement, please contact Avtech (info@avtechpulse.com) to arrange for the instrument to be returned to the factory for repair. Service is to be performed solely by qualified service personnel.

 Caution: High voltages are present inside the instrument during normal operation. Do not operate the instrument with the cover removed.

### RACK MOUNTING

A rack mounting kit is available. The -R5 rack mount kit may be installed after first removing the one Phillips screw on the side panel adjacent to the front handle.

### ELECTROMAGNETIC INTERFERENCE

To prevent electromagnetic interference with other equipment, all used outputs should be connected to shielded loads using shielded coaxial cables. Unused outputs should be terminated with shielded coaxial terminators or with shielded coaxial dust caps, to prevent unintentional electromagnetic radiation. All cords and cables should be less than 3m in length.

## MAINTENANCE

### REGULAR MAINTENANCE

This instrument does not require any regular maintenance.

On occasion, one or more of the four rear-panel fuses may require replacement. All fuses can be accessed from the rear panel. See the “FUSES” section for details.

### CLEANING

If desired, the interior of the instrument may be cleaned using compressed air to dislodge any accumulated dust. (See the “TOP COVER REMOVAL” section for instructions on accessing the interior.) No other cleaning is recommended.

### TRIGGER DAMAGE

The rear-panel TRIG input, used in the external trigger mode, is protected by a diode clamping circuit. However, the protection circuit is not foolproof, and it is possible for a grossly excessive signal to damage the trigger circuitry on the main timing control board (the 4×10 inch board on the right side of the instrument).

The IC that is most likely to fail under these conditions is installed in a socket. It is a standard TTL IC in a 16-pin plastic DIP package, model 74F151 or equivalent.

If you suspect that this IC has been damaged, turn off the power and replace this IC. It may be replaced by a 74F151, 74LS151, 74ALS151, or 74HCT151.

# WIRING DIAGRAMS

## WIRING OF AC POWER

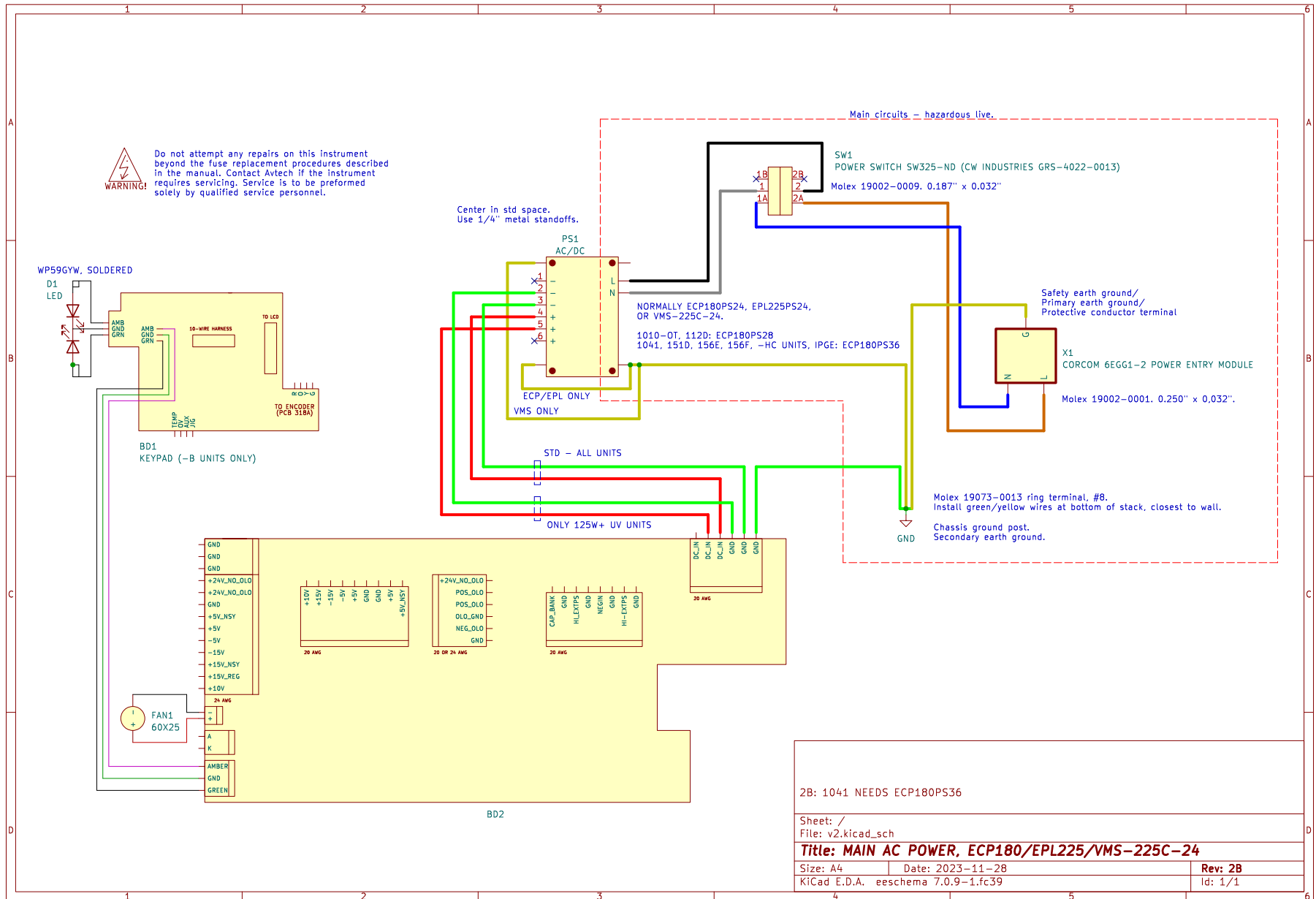

# PCB 158R7 - LOW VOLTAGE POWER SUPPLY

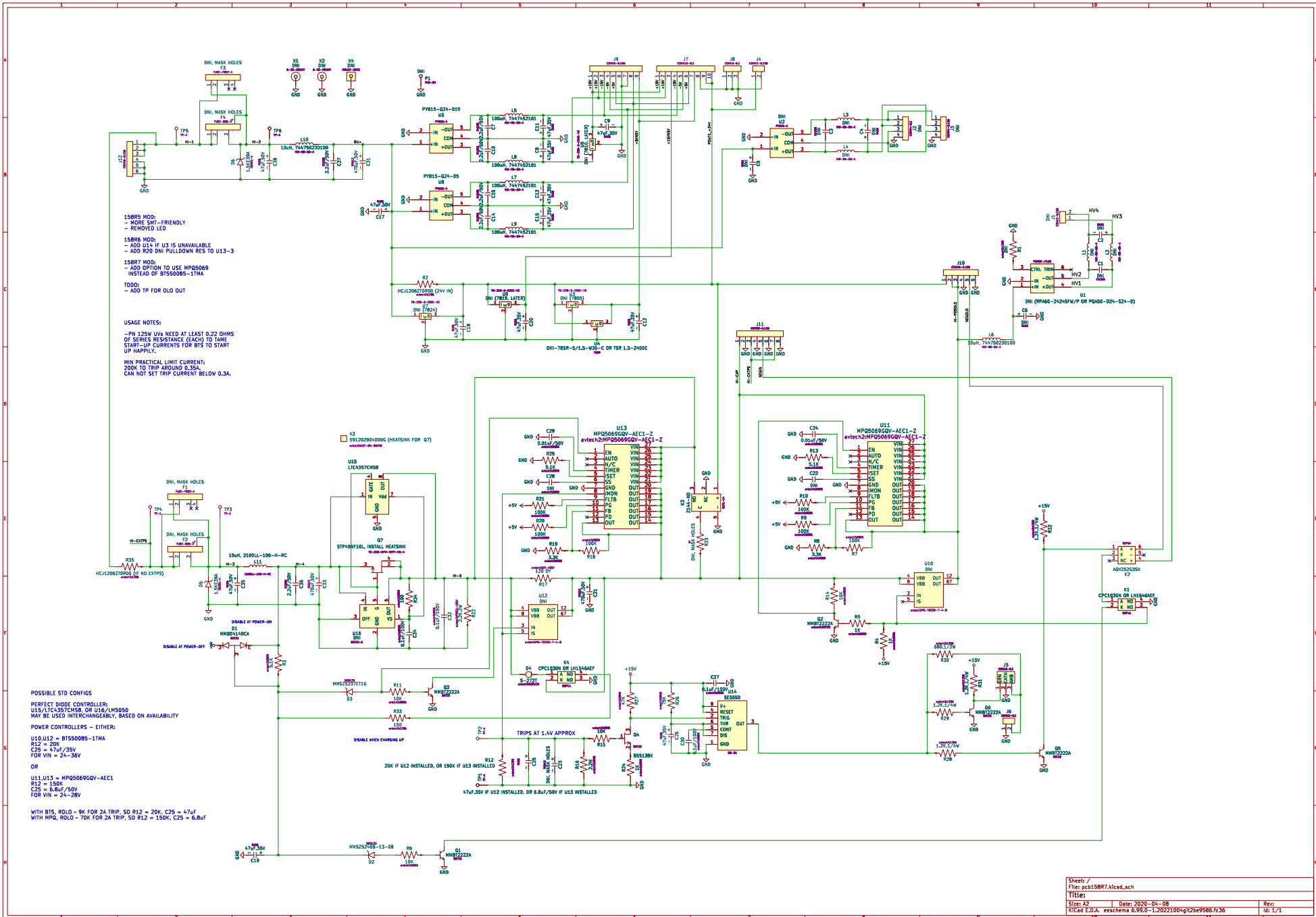

# PCB 235D - HIGH VOLTAGE DC POWER SUPPLY

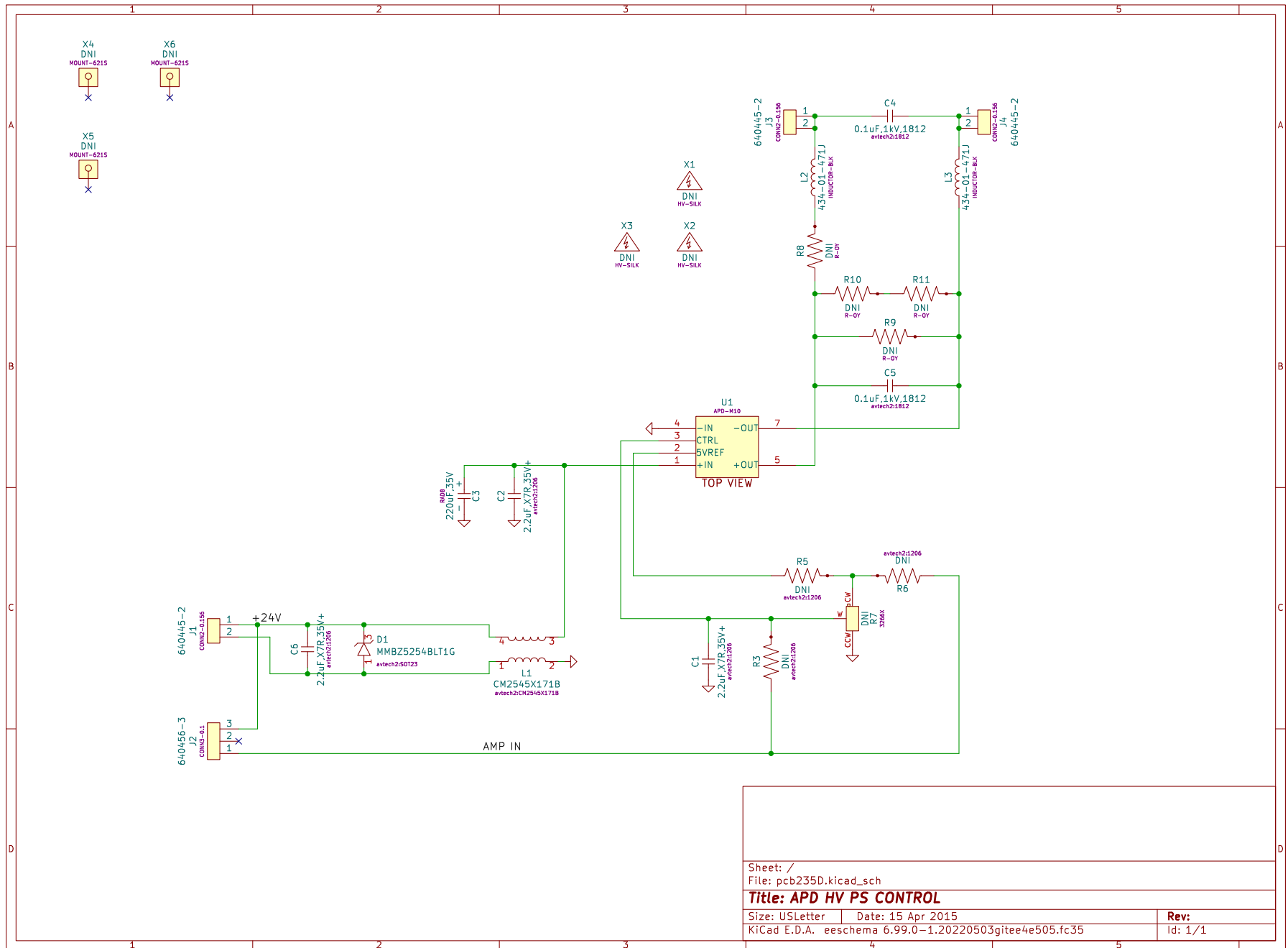

# PCB 284D - HIGH VOLTAGE DC POWER SUPPLY

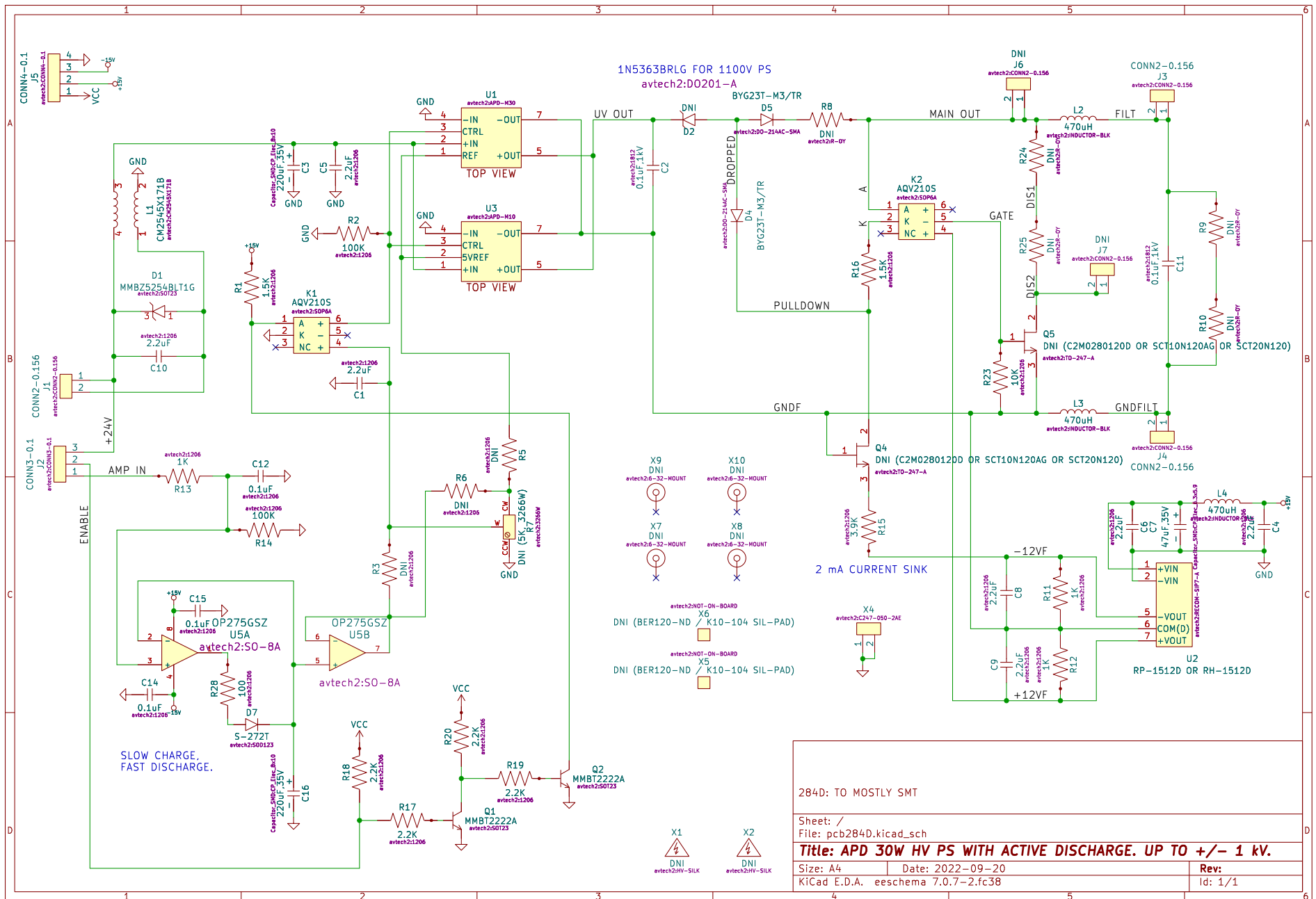

# PGA, 1 OF 4 - NARROW PULSE-GENERATOR DRIVE CIRCUIT

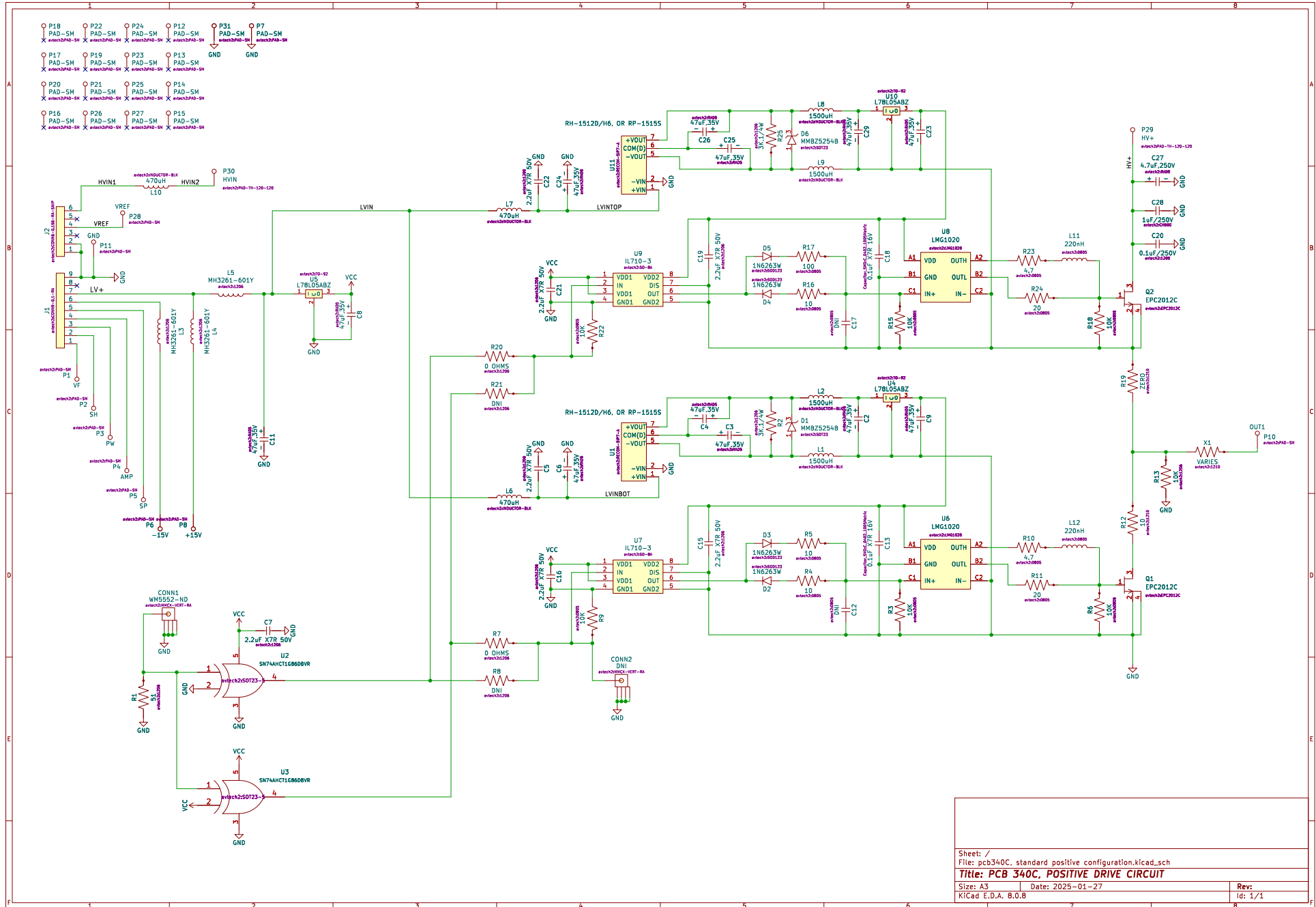

# PGA, 2 OF 4 - NARROW PULSE GENERATOR OUTPUT CIRCUIT

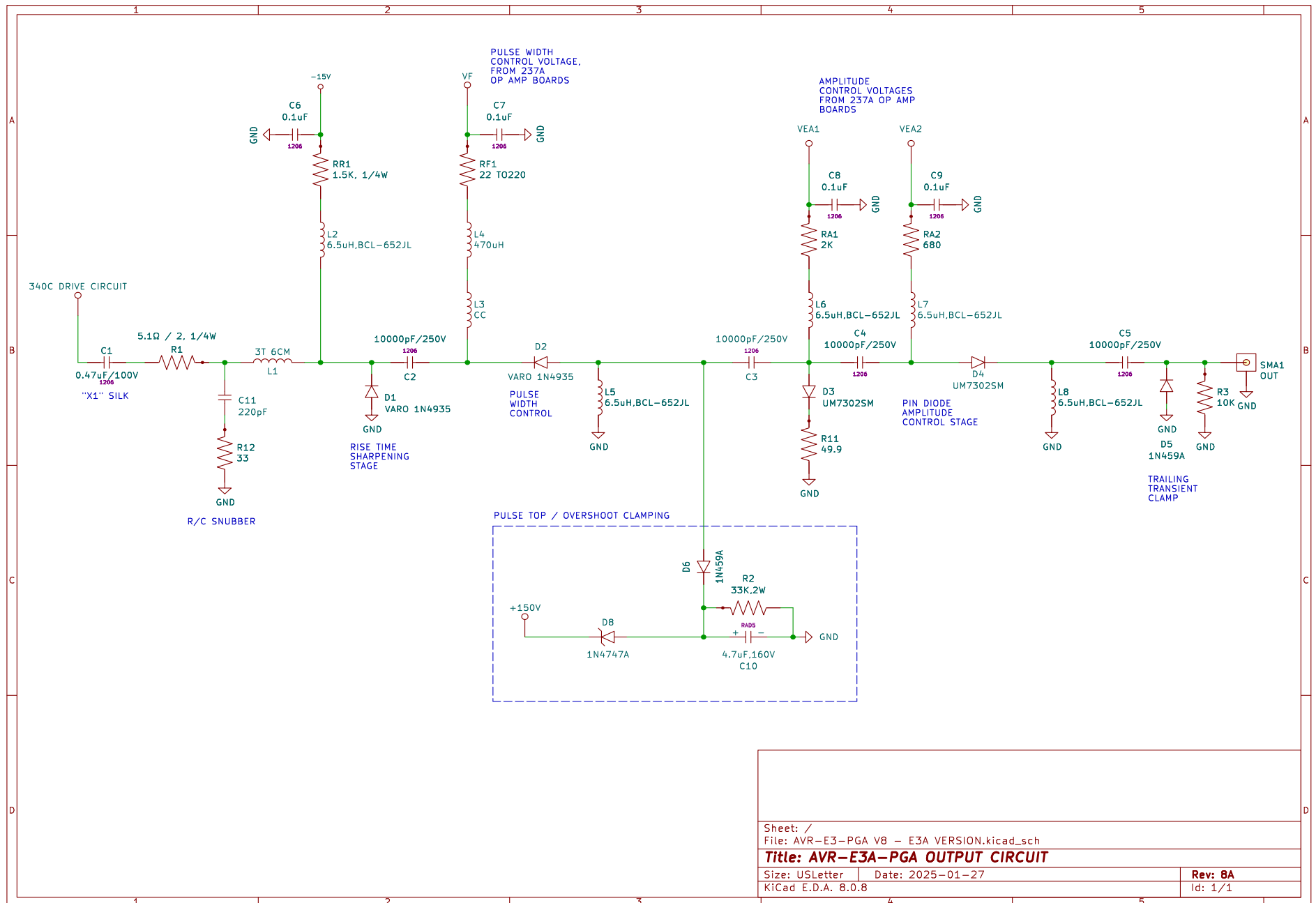



# PGA, 3 OF 4 - AMPLITUDE PIN DIODE BIAS CONTROL OP AMPS

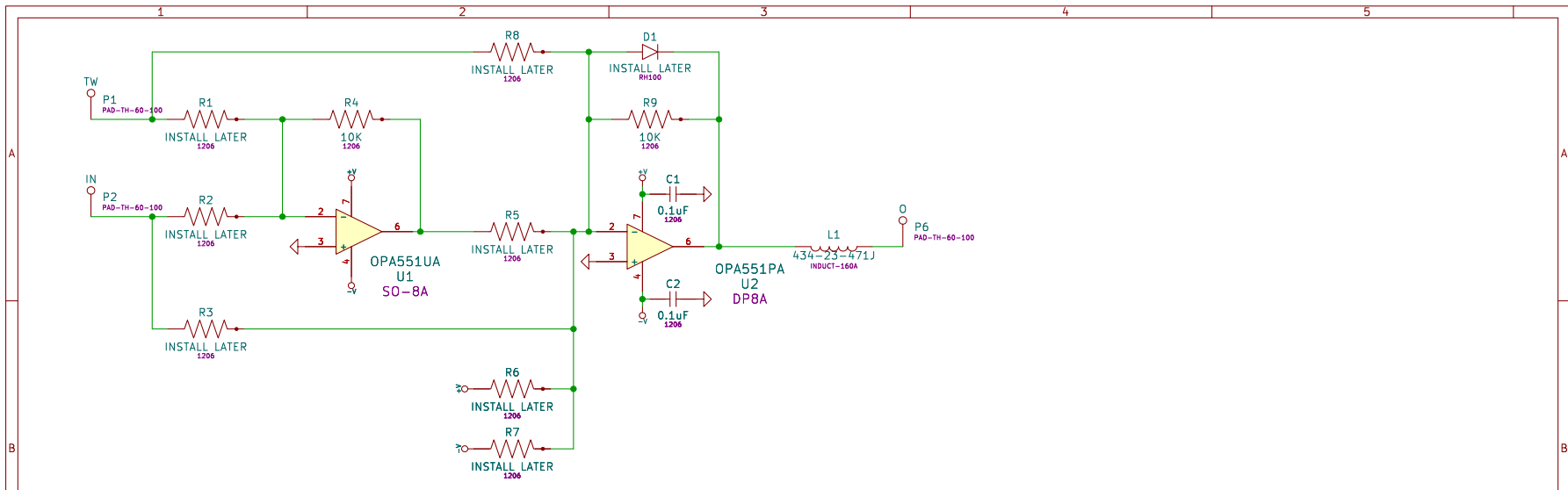

## -P MODULES (STANDARD)

REQUIRED IN ADDITION TO STANDARD 237A PARTS LIST:

R2 = 10K (-1 GAIN)  
R5 = 10K (-1 GAIN)

REQUIRED IN ADDITION TO STANDARD 237A PARTS LIST:

R2 = 10K (-1 GAIN)  
R5 = 10K (-1 GAIN)  
R1 = 10K (VPRF)

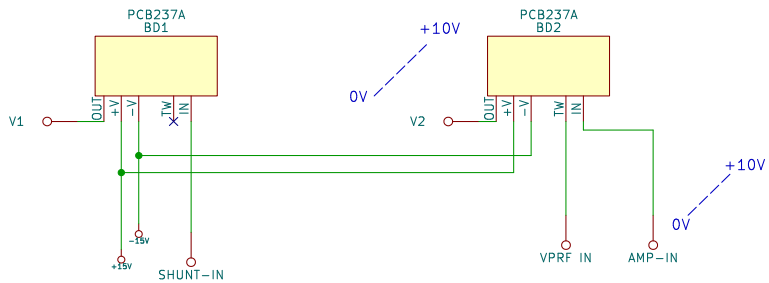

SHUNT-IN: 0 TO +10V, ADJUSTED IN SOFTWARE TO MINIMIZE PULSE WIDTH VARIATION WITH AMPLITUDE AND PROVIDE MINIMIZED OVERSHOOT.

AMP-IN: 0 = MIN OUT, +10V = MAX OUT, HIGHLY NONLINEAR.

## -N MODULES (RARE)

REQUIRED IN ADDITION TO STANDARD 237A PARTS LIST:

R3 = 10K (-1 GAIN)

REQUIRED IN ADDITION TO STANDARD 237A PARTS LIST:

R3 = 10K (-1 GAIN)  
R8 = 10K (VPRF)

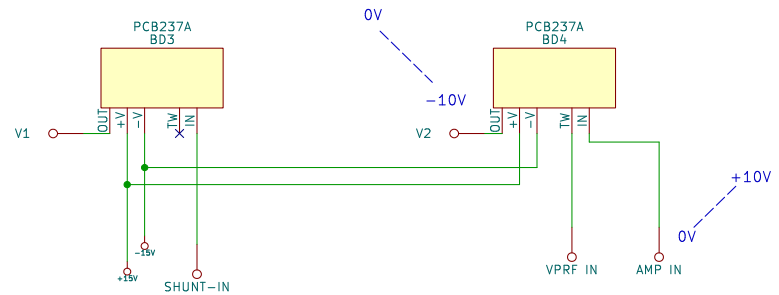

Sheet: /  
File: pcb237A, -EA with two inputs, V1.kicad\_sch

**Title: PIN DIODE AMPLITUDE CONTROL**

Size: USLetter Date: 2025-01-27

Rev: 1C

KiCad E.D.A. 8.0.8

Id: 1/1

# PGA, 4 OF 4 - PULSE WIDTH BIAS CONTROL OP AMPS

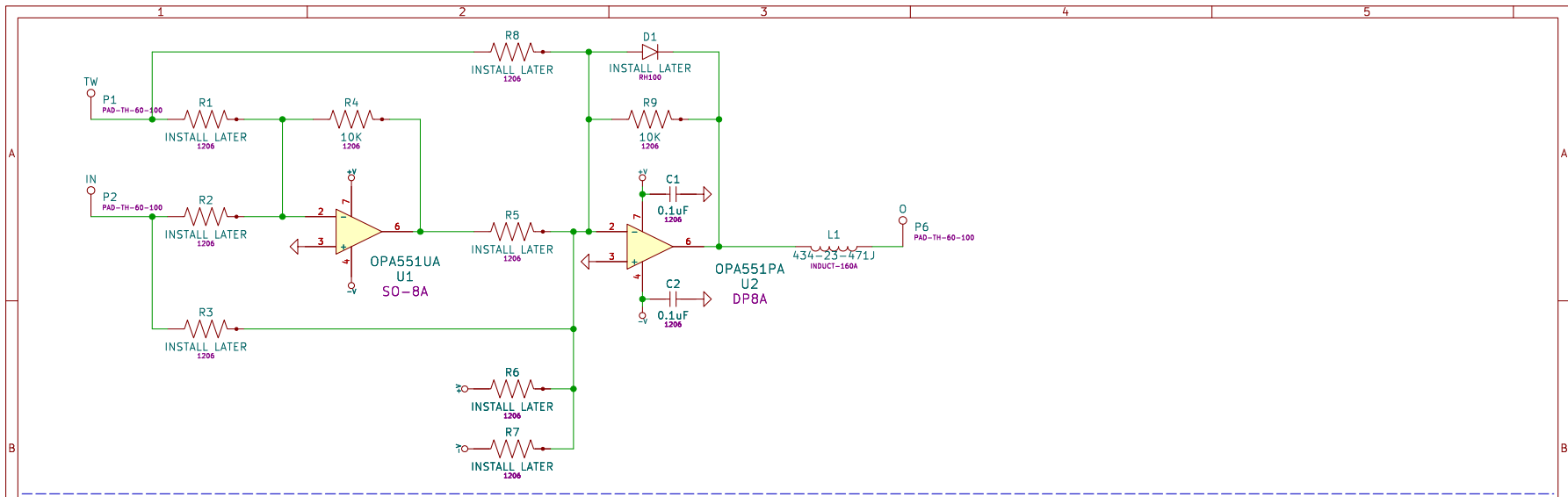

REQUIRED IN ADDITION TO  
STANDARD 237A PARTS LIST:

R3 = 7.5K (-1 .33GAIN)

VTR IS FIXED AT -15V, AS PER S/N 13618

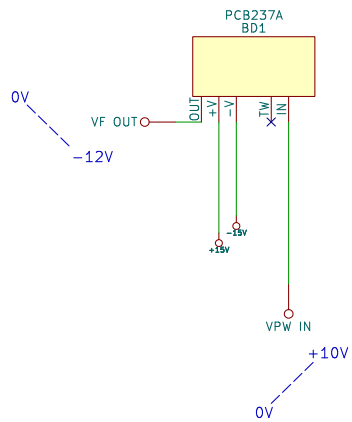

PW/PRF TWEAKS ARE IN 216F PCB.

Sheet: /		
File: pcb237A, AVR-E2-PGA, AVR-E3-PGA, AVR-E5, PW, V4.kicad_sch		
<b>Title: AVR-E2/E3/E3A/E5-PGA, PULSE WIDTH BIAS CONTROL</b>		
Size: USLetter	Date: 2025-01-27	Rev: 4A
KiCad E.D.A. 8.0.8		Id: 1/1

# PGBC-P, 1 OF 3 - WIDE PULSE GENERATOR DRIVE CIRCUIT

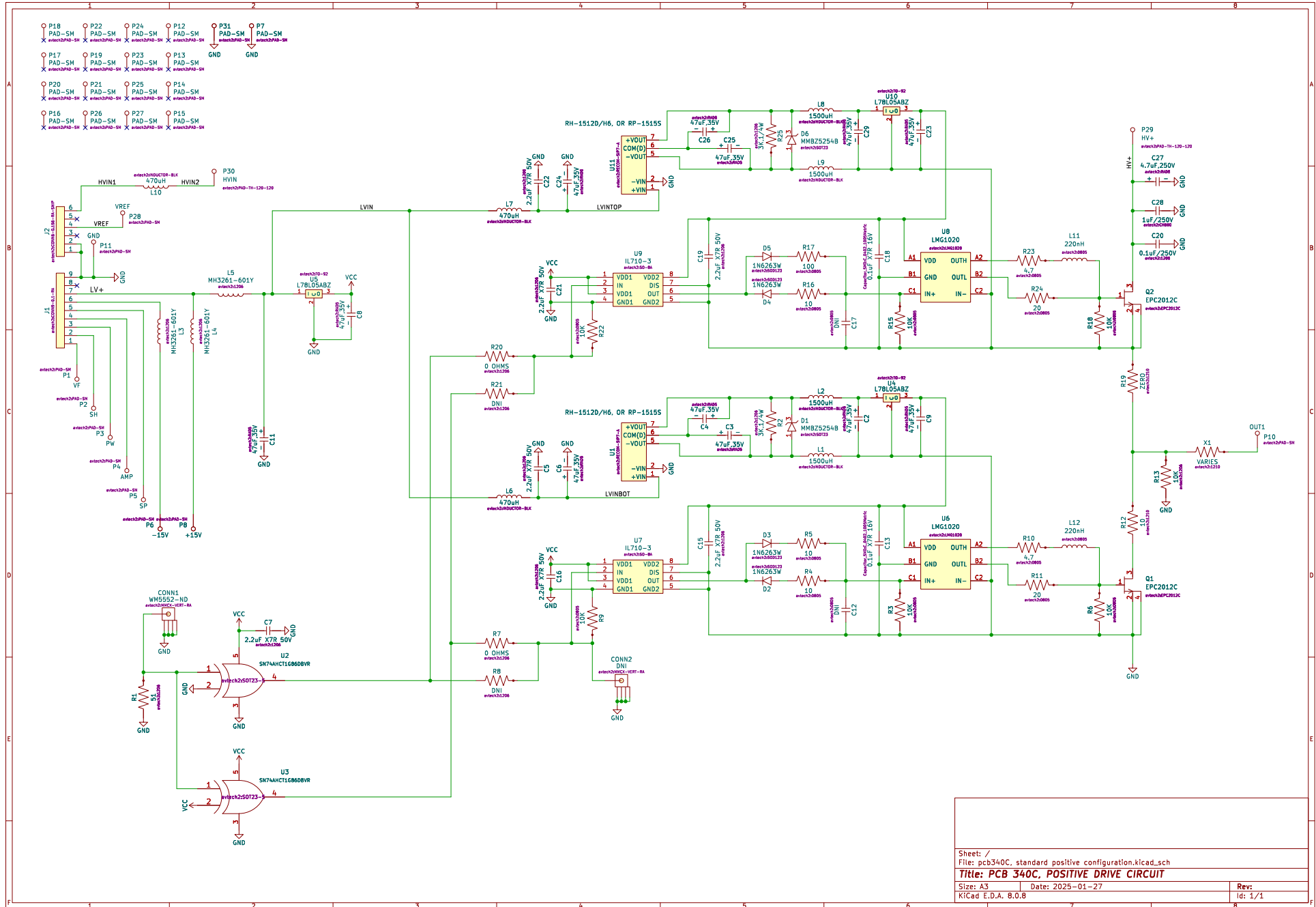

Sheet: /	File: pcb340c_standard_positive_configuration.kicad_sch
<b>Title: PCB 340C, POSITIVE DRIVE CIRCUIT</b>	
Size: A3	Date: 2025-01-27
KiCad E.D.A. 8.0.8	Rev: 1d/1/1

# PGBC-P, 2 OF 3 - WIDE PULSE GENERATOR OUTPUT CIRCUIT

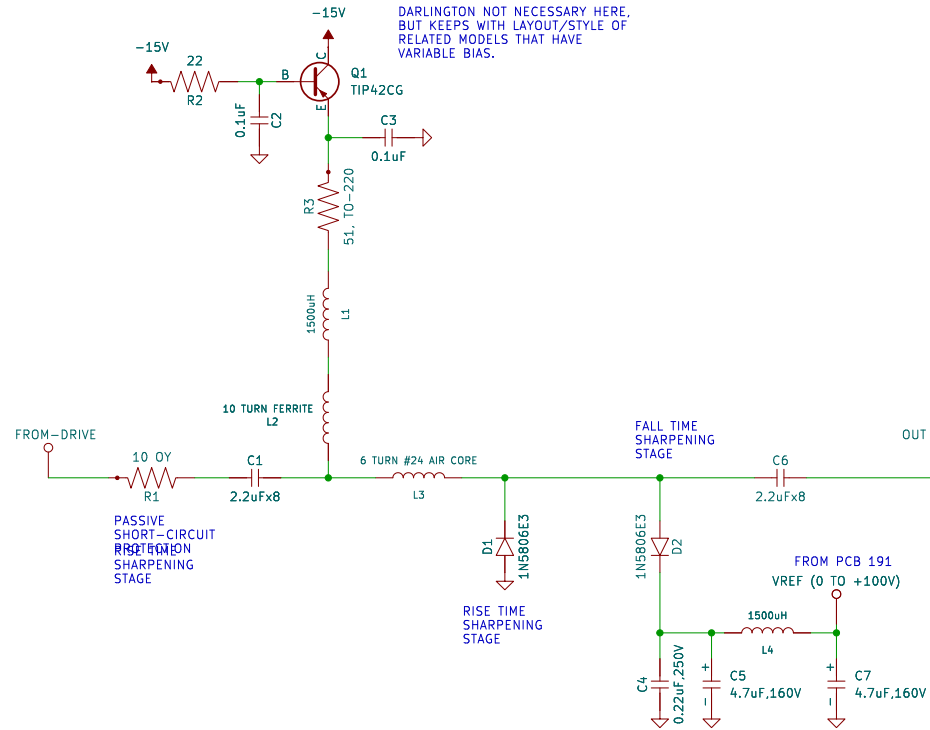

Sheet: /		
File: PGBC-P V4A.kicad_sch		
<b>Title: AVR-E3A-PBGC-P OUTPUT CIRCUIT</b>		
Size: A4	Date: 2025-01-27	Rev: 4A
KiCad E.D.A. 8.0.8		Id: 1/1

# PGBC-P, 3 OF 3 - AMPLITUDE CLAMP VOLTAGE BIAS CIRCUIT

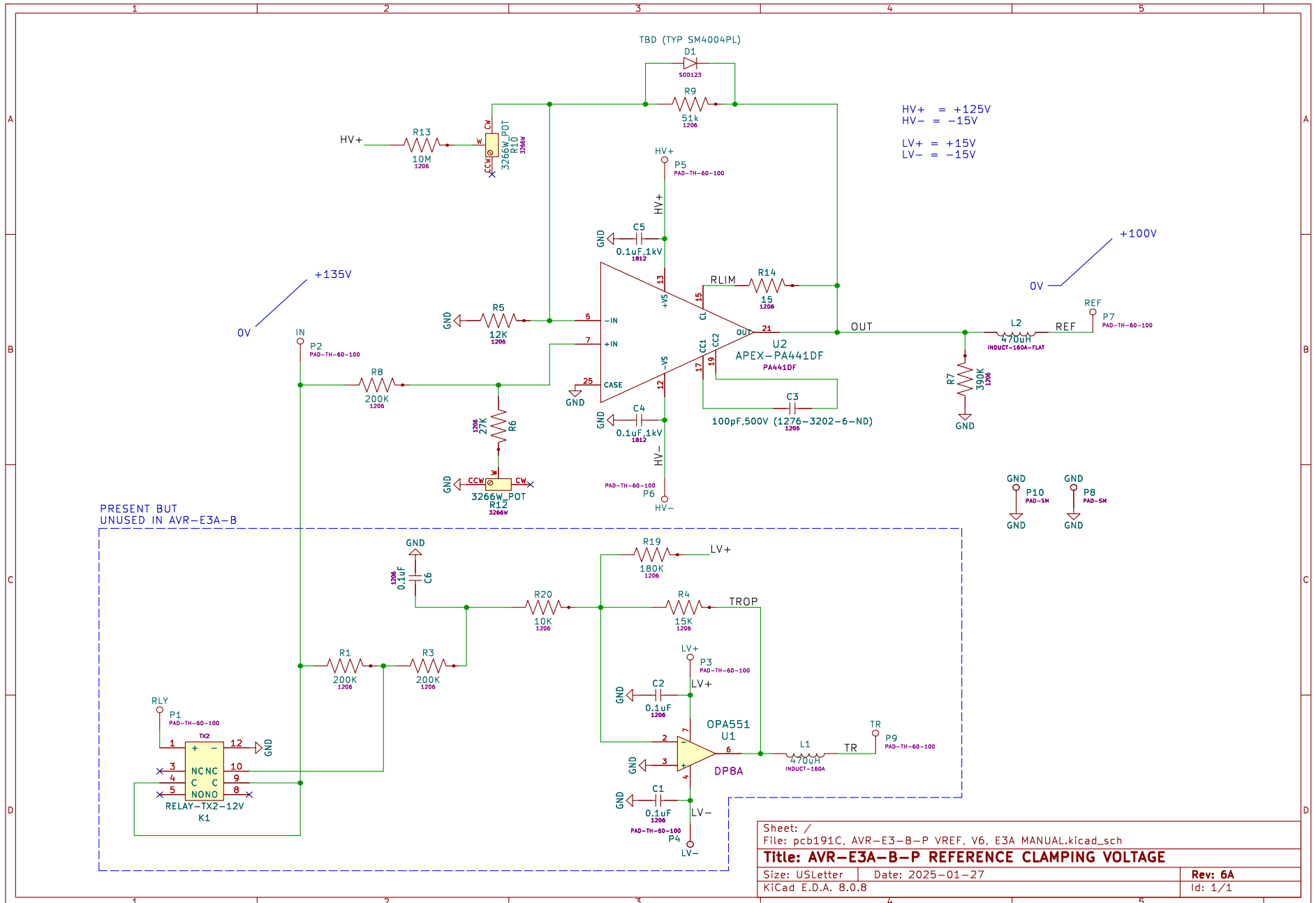

# PCB 335C - TRIGGER MULTIPLEXER

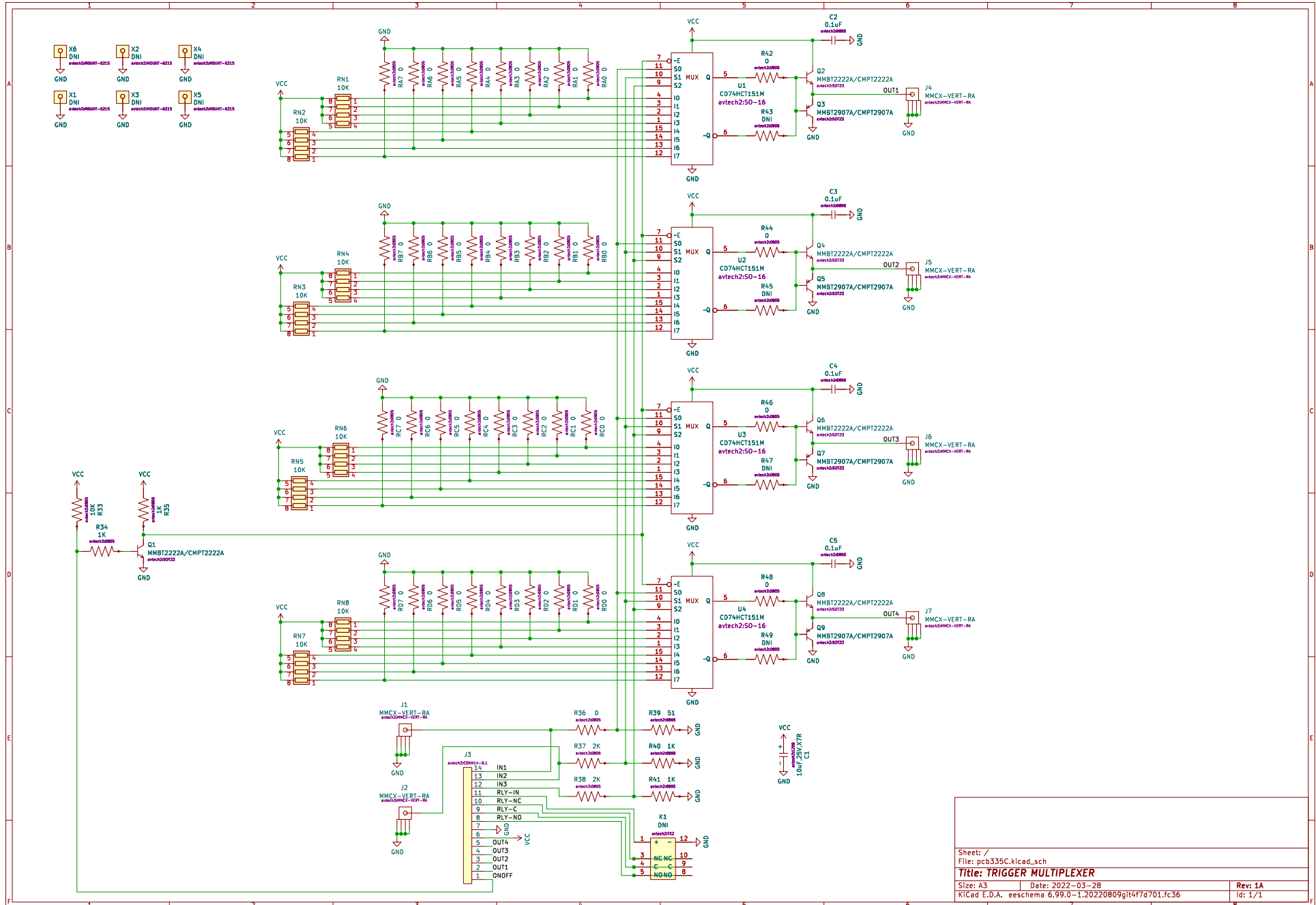

Sheet: /		File: pcb335C.kicad_sch	
<b>Title: TRIGGER MULTIPLEXER</b>			
Size: A3	Date: 2022-03-28	Rev: 1A	
KiCad E.D.A. eeschema 6.99.0-1.20220809git4f7d701.fc36		Id: 1/1	

# PCB 231A - DC OFFSET SOURCE

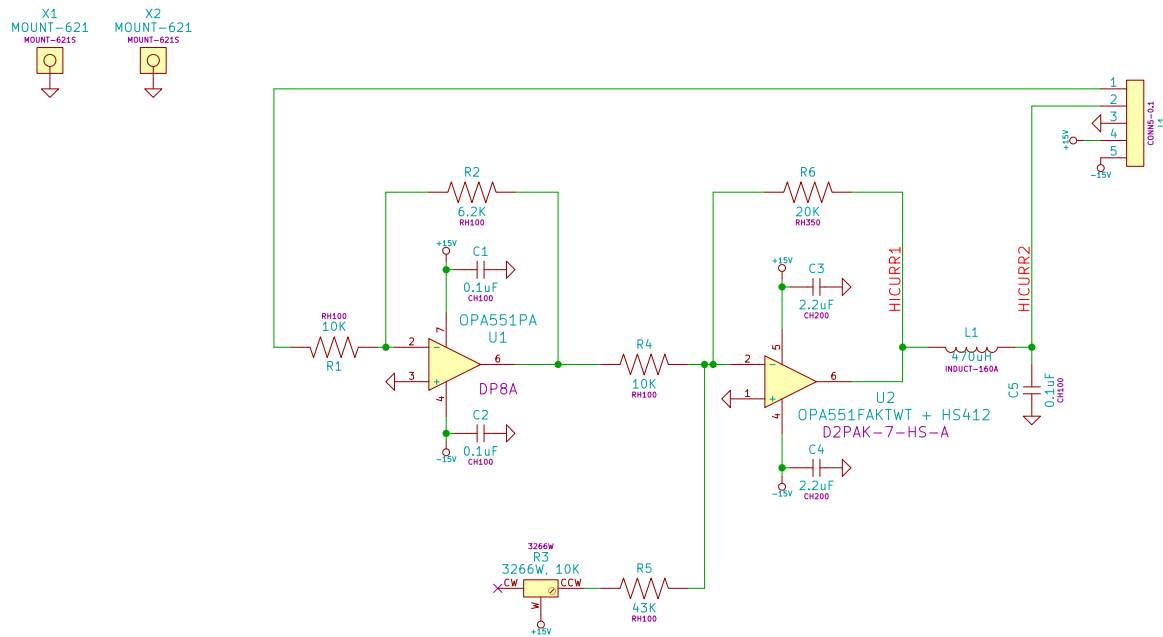

File: pcb231A.sch	
Sheet: /	
Title: -0T, -5V TO +5V OFFSET	
Size: A4	Date: 20 nov 2012
Rev:	
KiCad E.D.A.	Id: 1/1

# PCB 216F - RELAY DRIVER AND TWEAKING OP AMPS

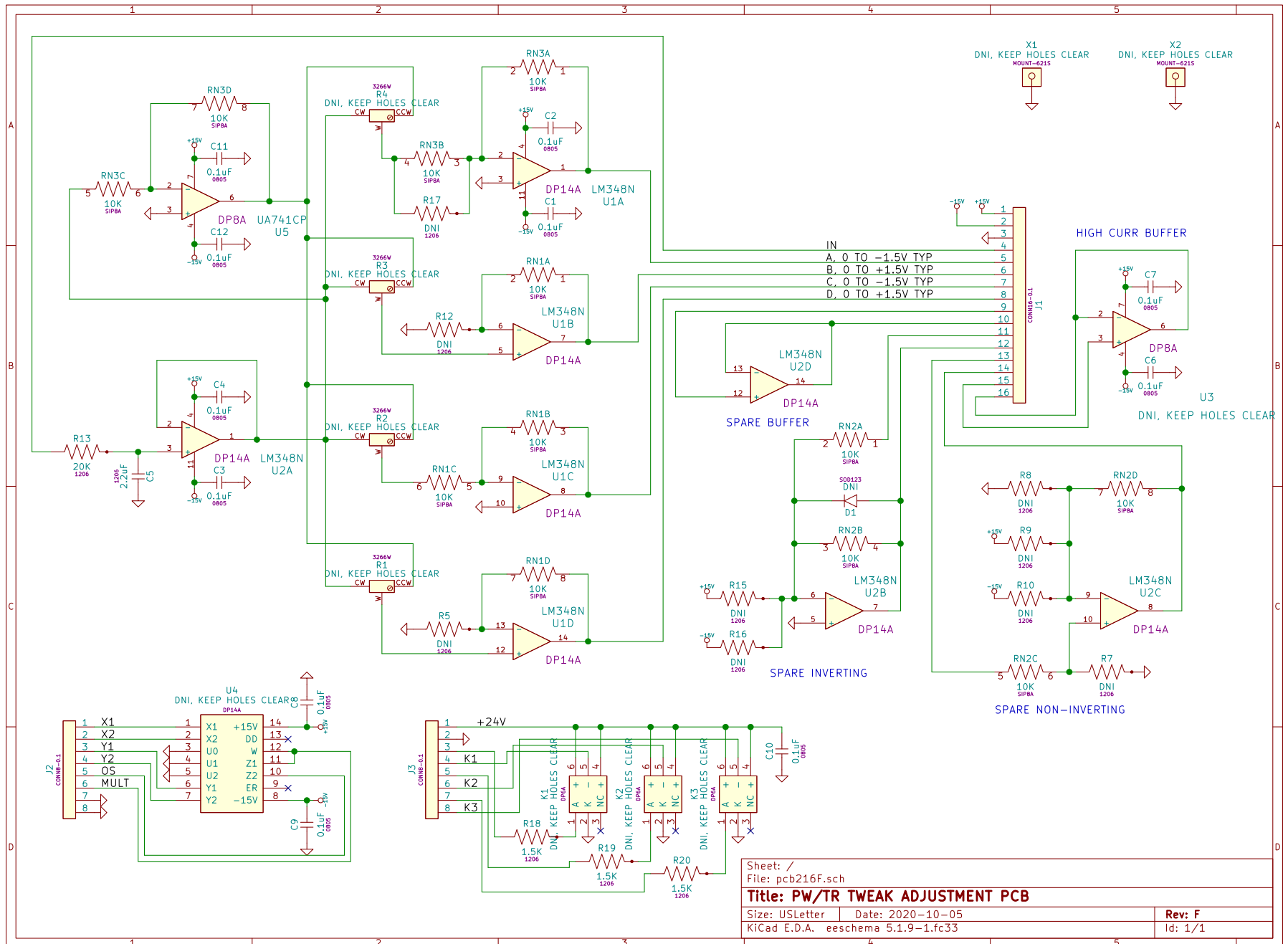

Sheet: /  
 File: pcb216F.sch  
**Title: PW/TR TWEAK ADJUSTMENT PCB**  
 Size: USLetter    Date: 2020-10-05    Rev: F  
 KiCad E.D.A. eeschema 5.1.9-1.fc33    Id: 1/1



# PCB 104H - KEYPAD / DISPLAY BOARD

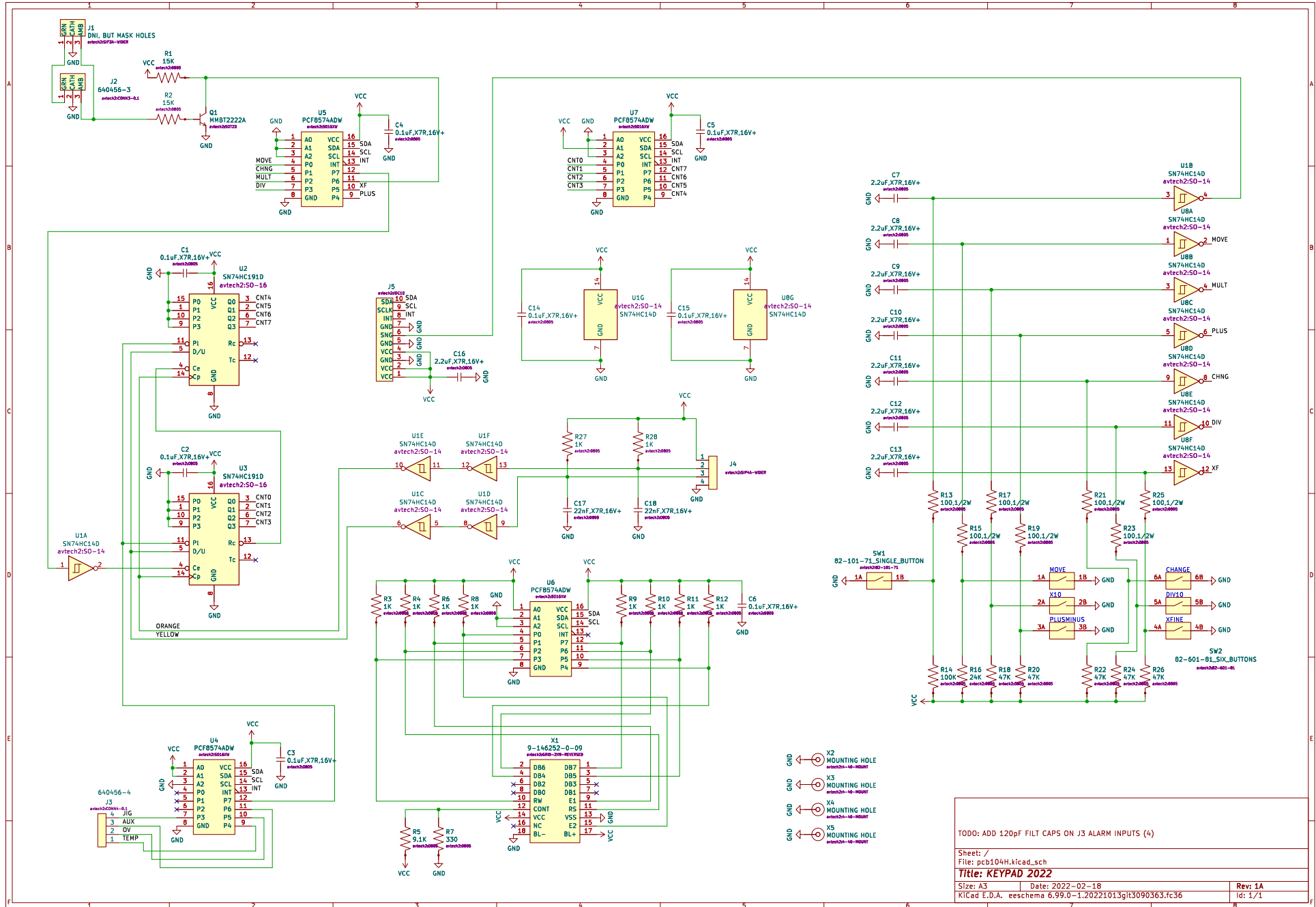

# PCB 295E - MAIN CONTROL BOARD, 1 OF 13, TOP-LEVEL

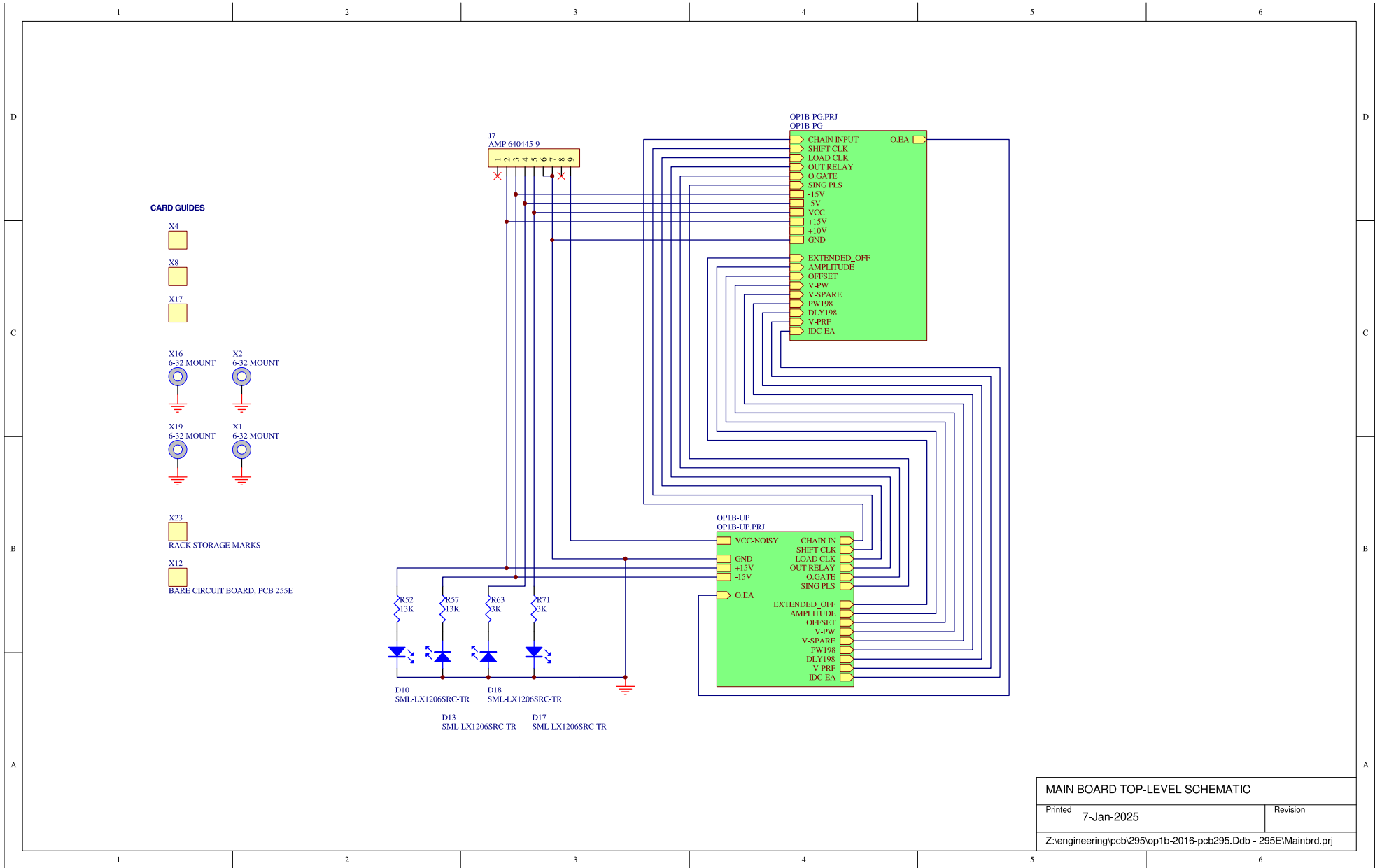

MAIN BOARD TOP-LEVEL SCHEMATIC	
Printed 7-Jan-2025	Revision
Z:\engineering\pcb\295\op1b-2016-pcb295.Ddb - 295E\Mainbrd.prj	

# PCB 295E - MAIN CONTROL BOARD, 2 OF 13, MICROCONTROLLER TOP-LEVEL

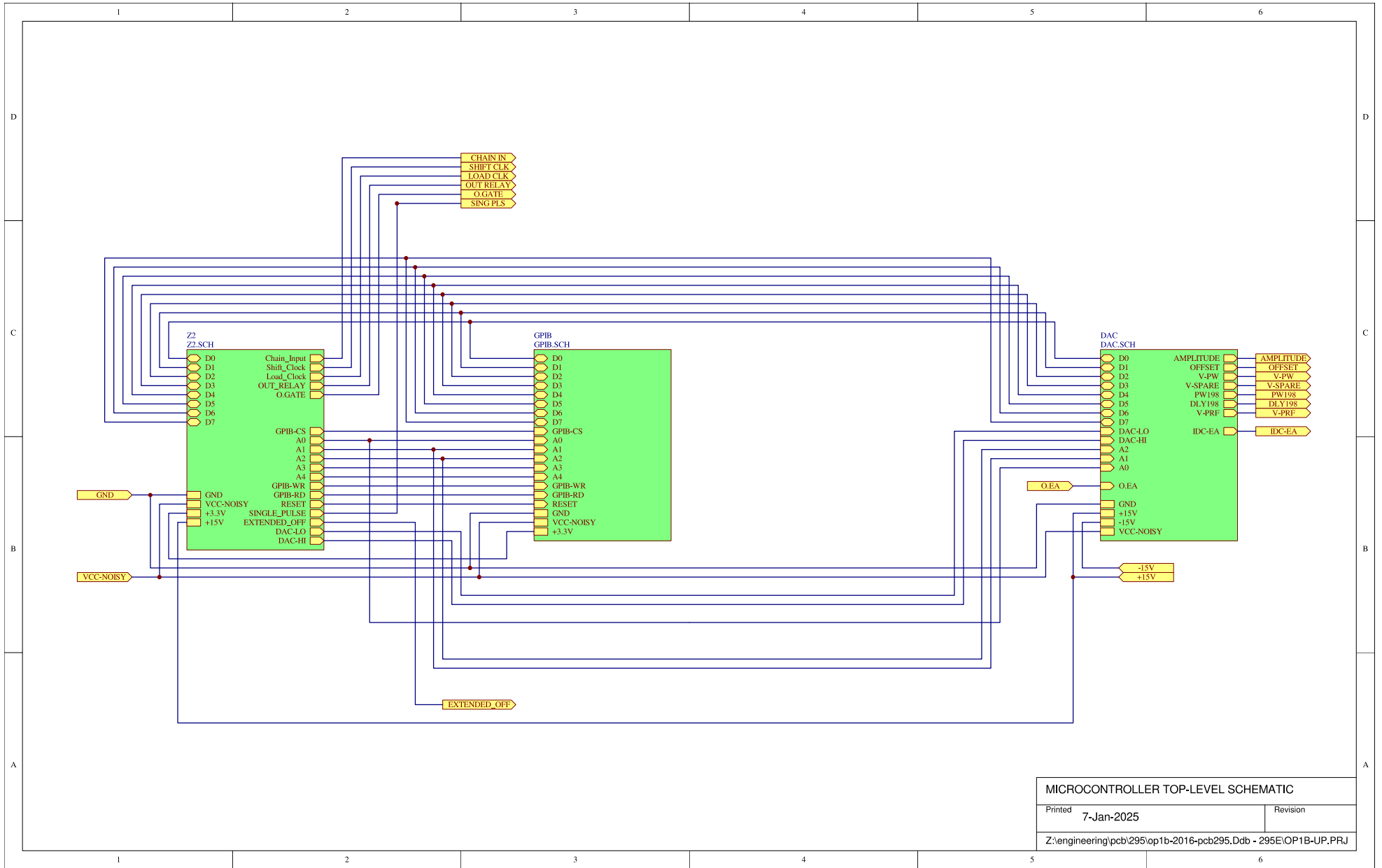

MICROCONTROLLER TOP-LEVEL SCHEMATIC	
Printed	7-Jan-2025
Revision	
Z:\engineering\pcb\295\op1b-2016-pcb295.Ddb - 295E\OP1B-UP.PRJ	

# PCB 295E - MAIN CONTROL BOARD, 3 OF 13, EMBEDDED CONTROLLER

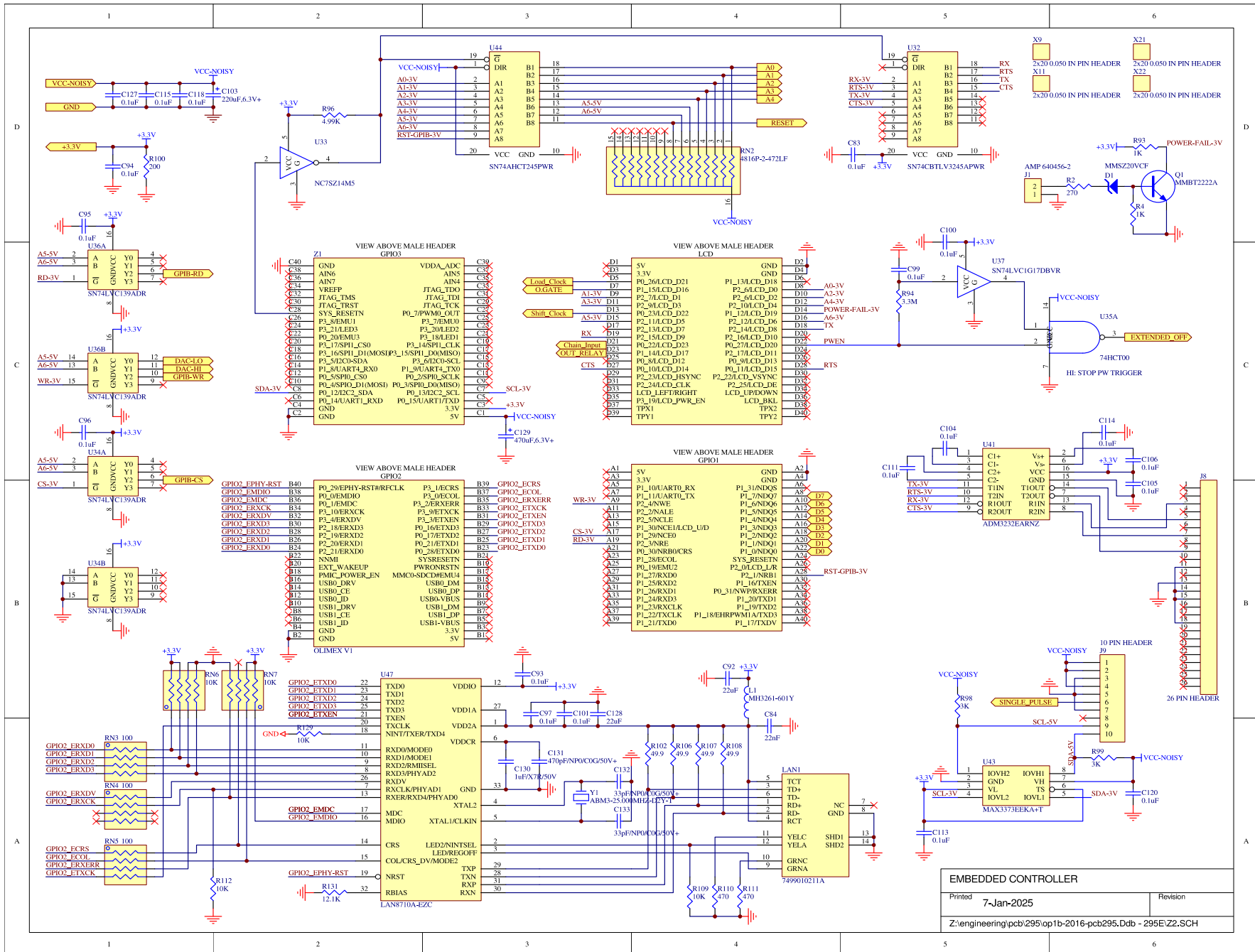

# PCB 295E - MAIN CONTROL BOARD, 4 OF 13, GPIB INTERFACE

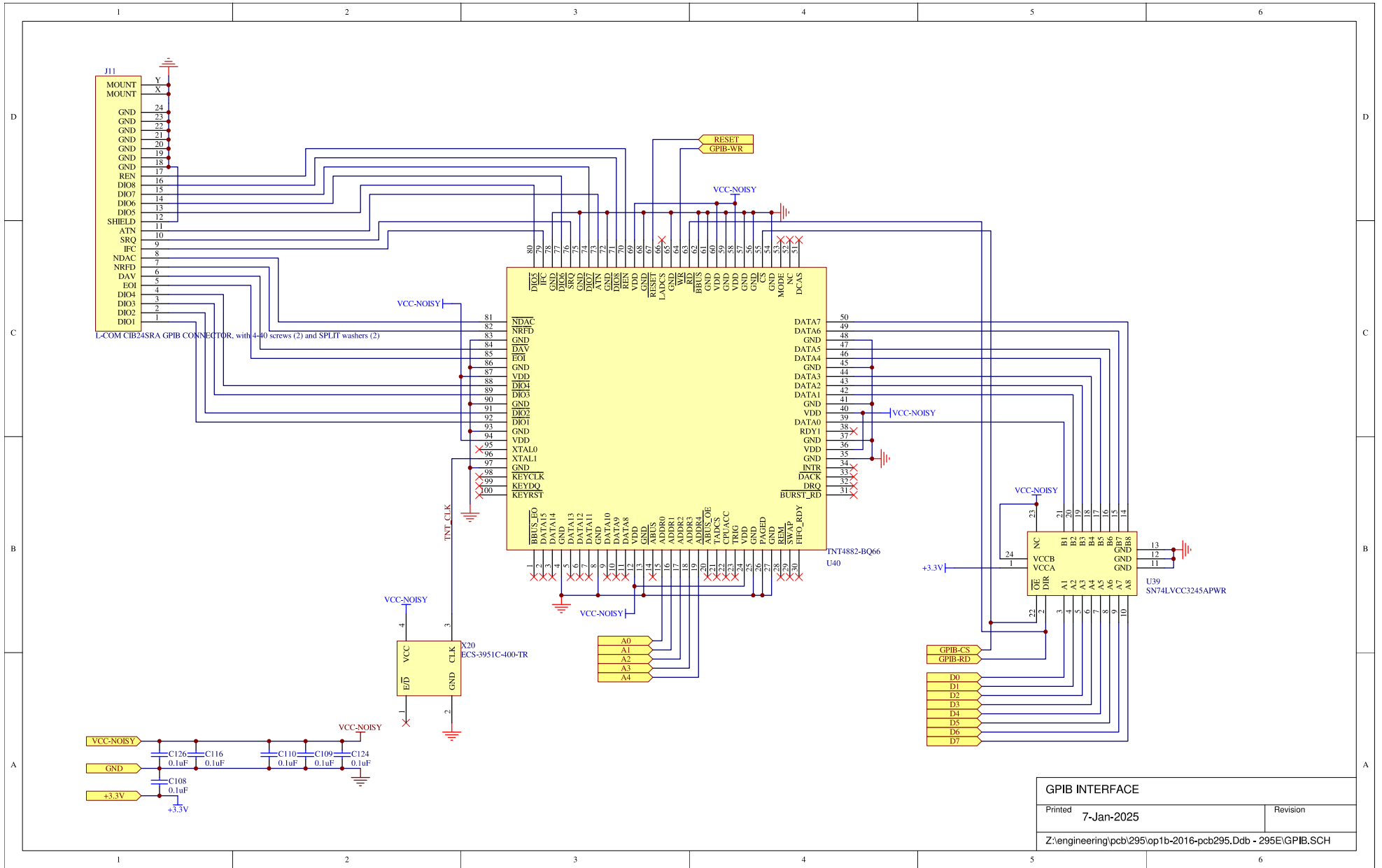

GPIB INTERFACE	
Printed	7-Jan-2025
Revision	
Z:\engineering\pcb\295\op1b-2016-pcb295.Ddb - 295E\GPIB.SCH	

# PCB 295E - MAIN CONTROL BOARD, 5 OF 13, DACs

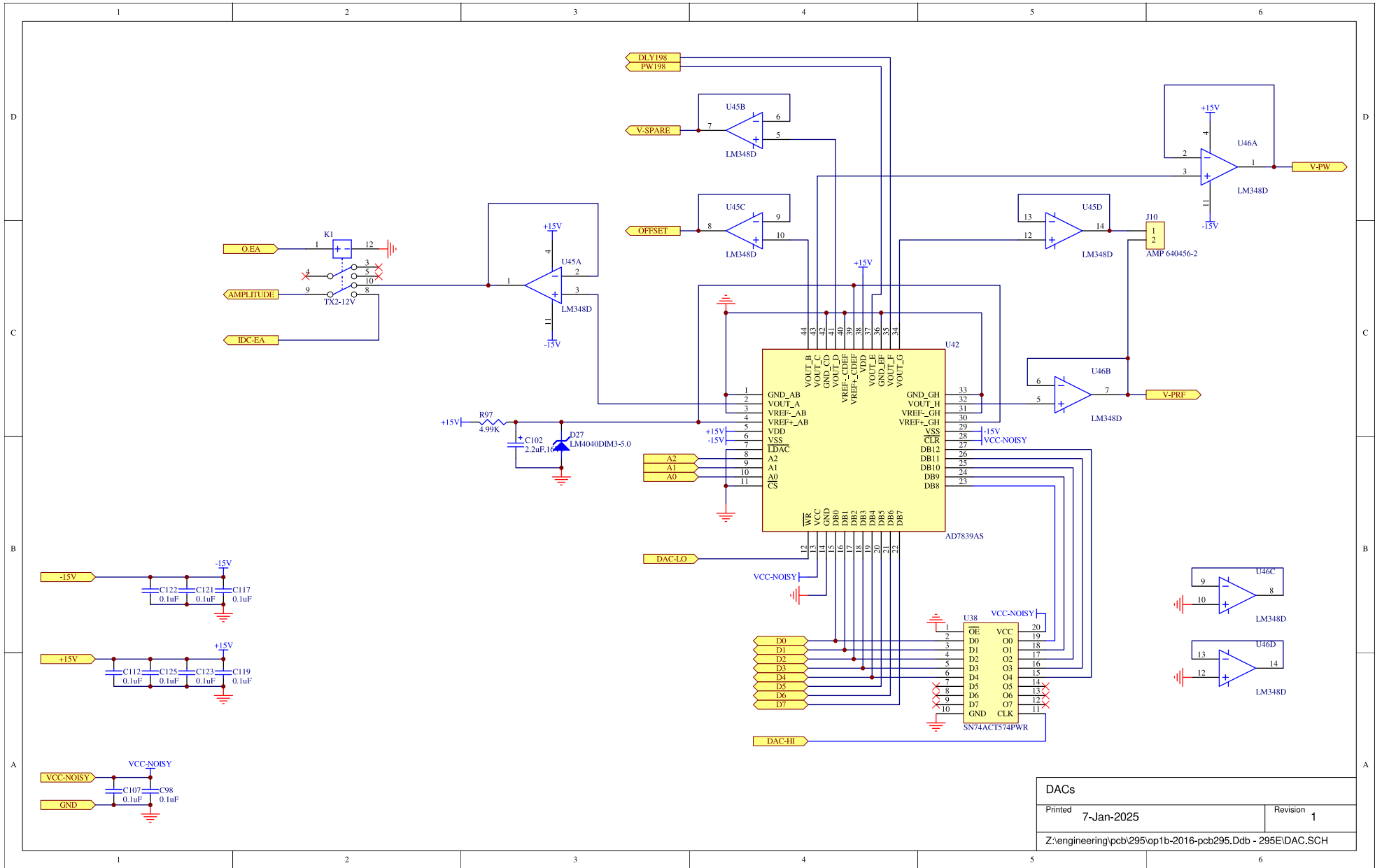

DACs	
Printed	7-Jan-2025
Revision	1
Z:\engineering\pcb\295\op1b-2016-pcb295.Ddb - 295E\DAC.SCH	

# PCB 295E - MAIN CONTROL BOARD, 6 OF 13, TIMING TOP-LEVEL

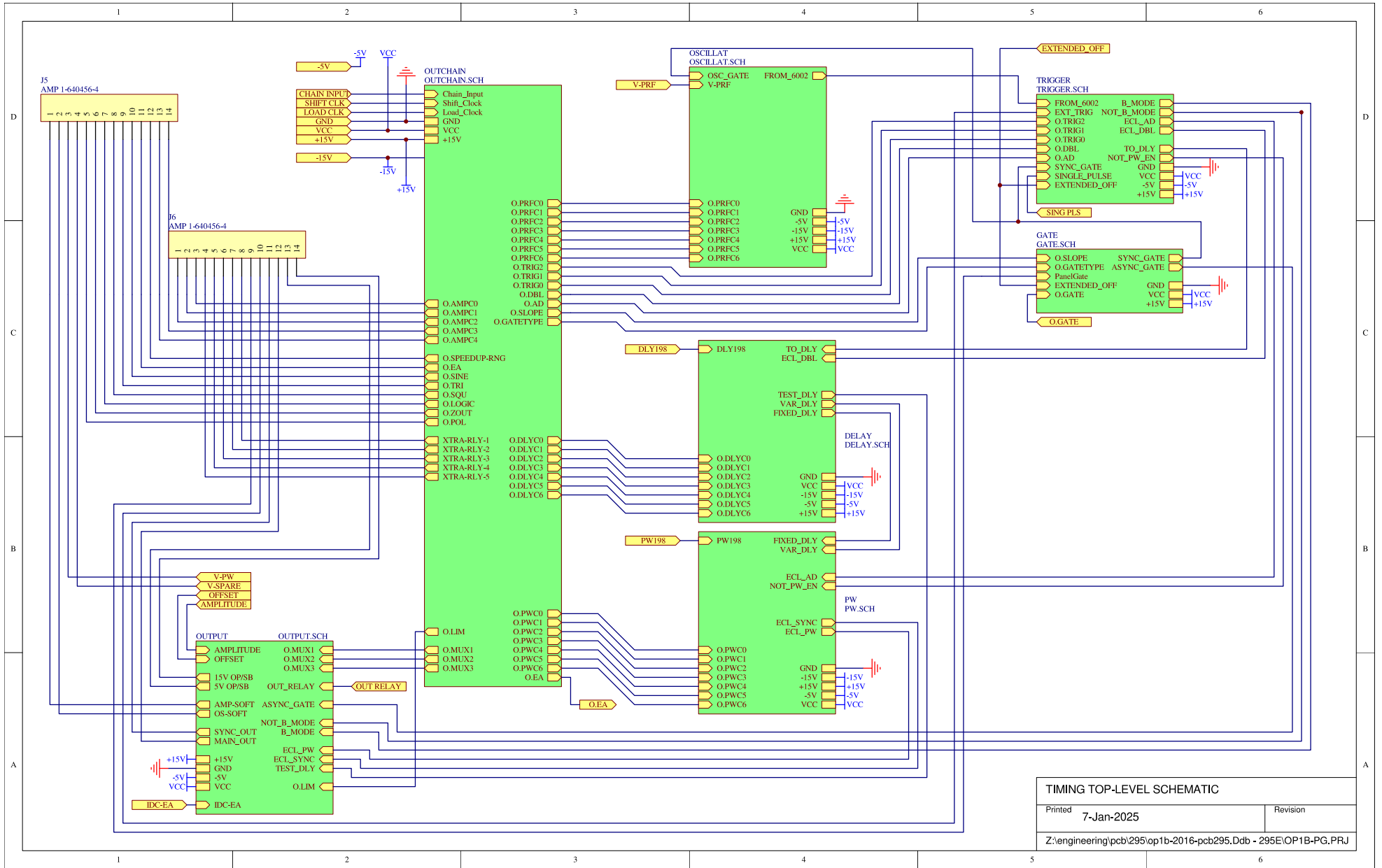

TIMING TOP-LEVEL SCHEMATIC	
Printed	7-Jan-2025
Revision	
Z:\engineering\pcb\295\op1b-2016-pcb295.Ddb - 295E\OP1B-PG.PRJ	

# PCB 295E - MAIN CONTROL BOARD, 7 OF 13, GATE CIRCUIT

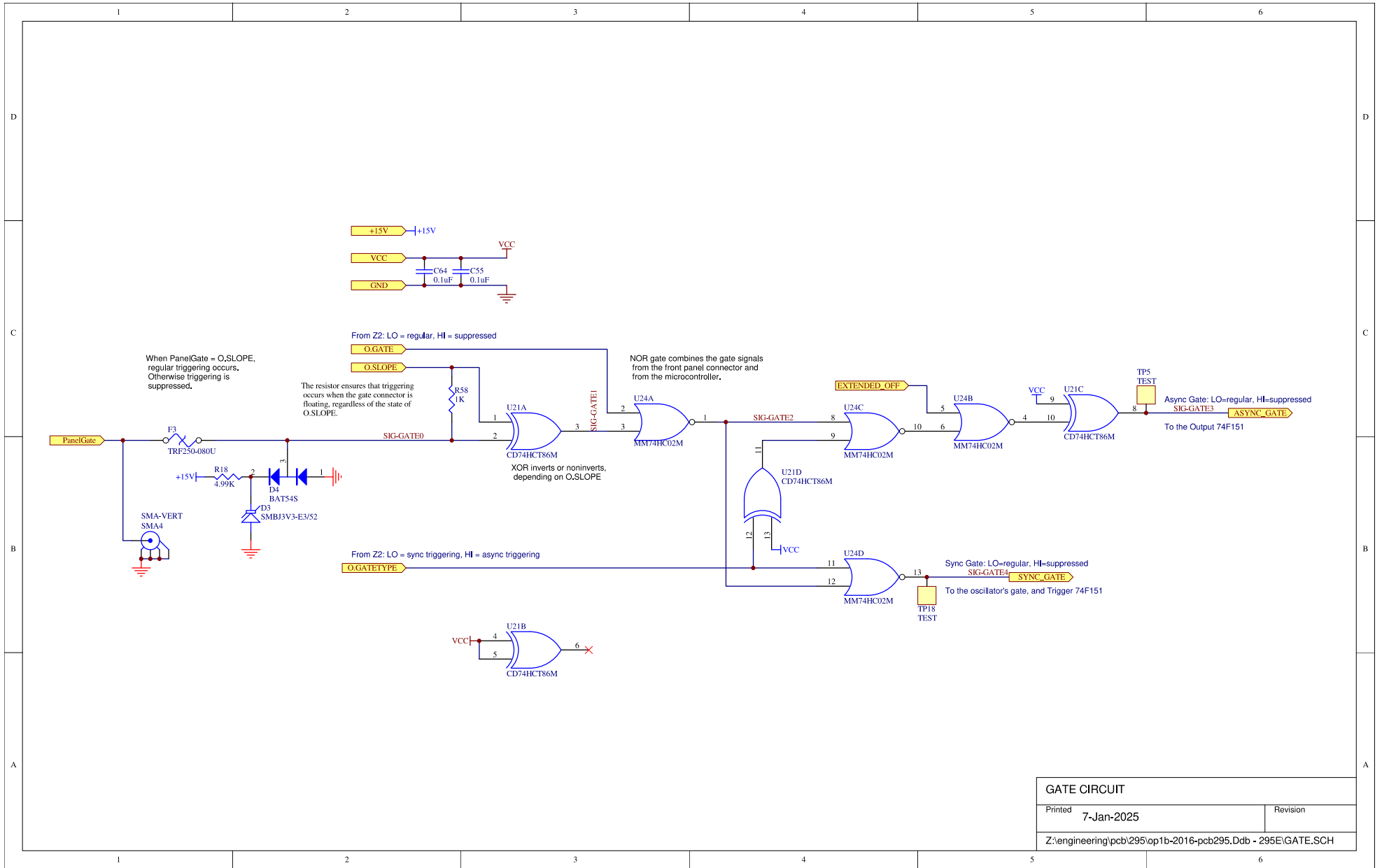

GATE CIRCUIT	
Printed 7-Jan-2025	Revision
Z:\engineering\pcb\295\op1b-2016-pcb295.Ddb - 295E\GATE.SCH	



# PCB 295E - MAIN CONTROL BOARD, 8 OF 13, OSCILLATOR

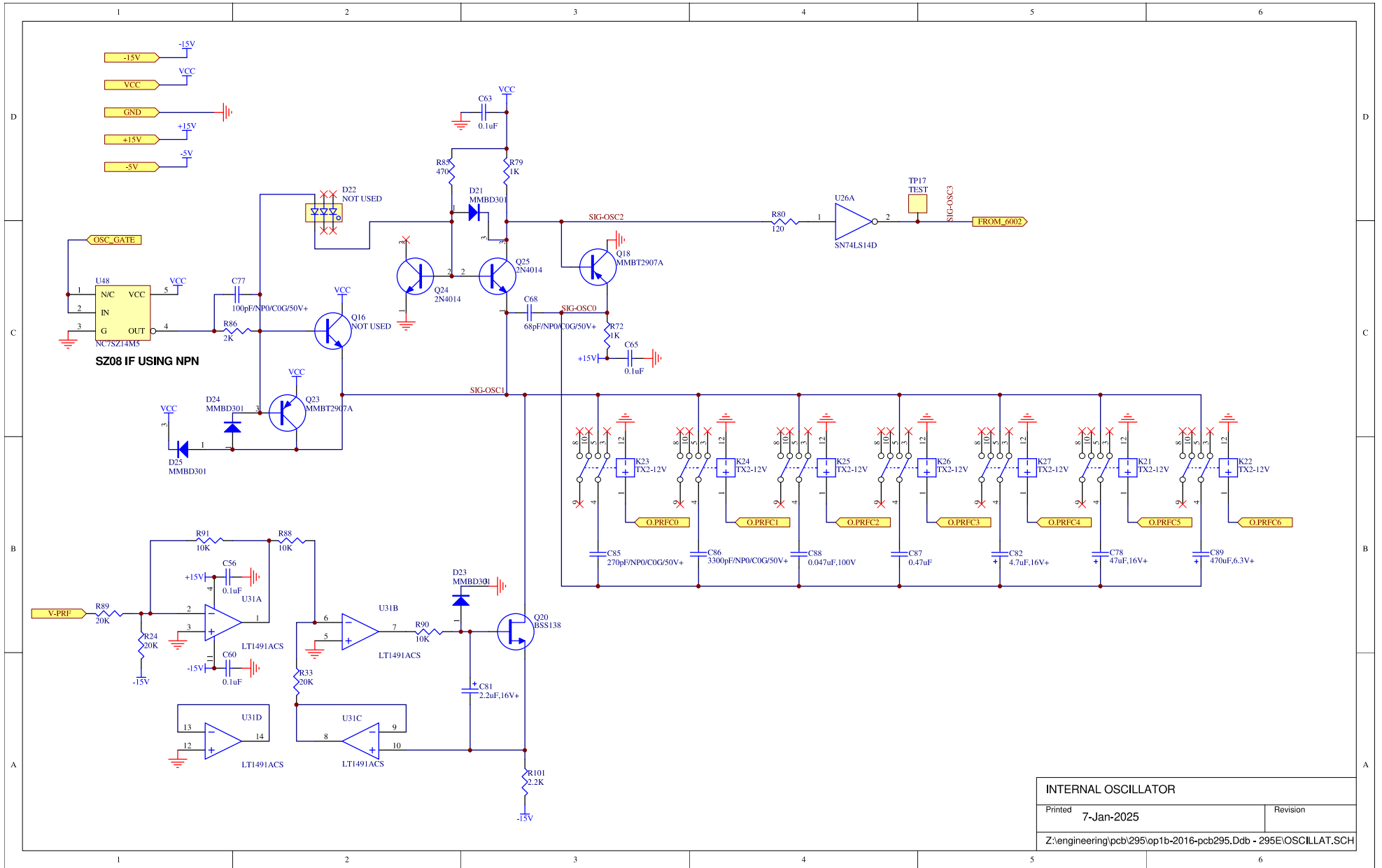

INTERNAL OSCILLATOR	
Printed	7-Jan-2025
Revision	
Z:\engineering\pcb\295\op1b-2016-pcb295.Ddb - 295E\OSCILLAT.SCH	

# PCB 295E - MAIN CONTROL BOARD, 9 OF 13, TTL OUTPUTS

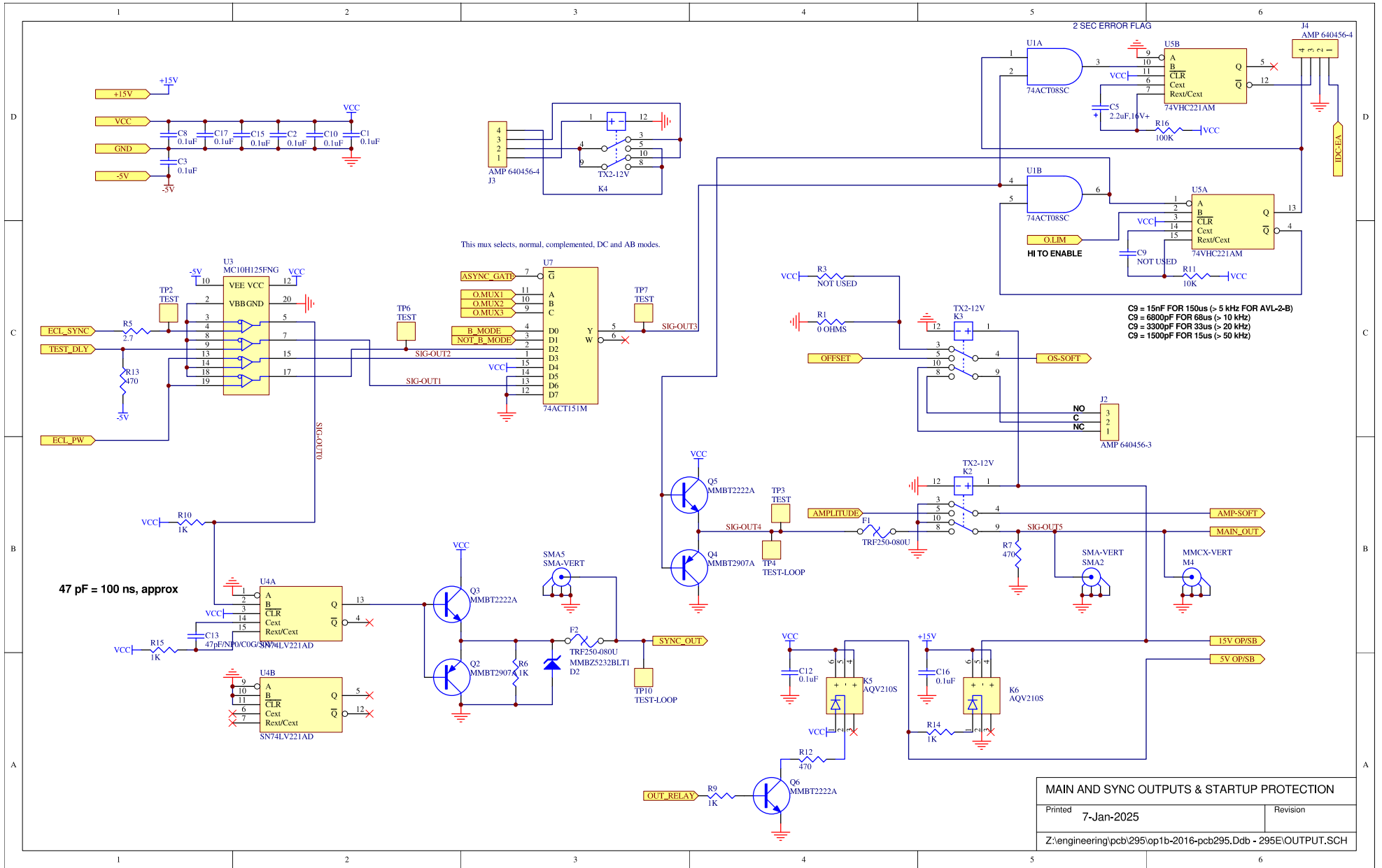

## MAIN AND SYNC OUTPUTS & STARTUP PROTECTION

Printed	7-Jan-2025	Revision
Z:\engineering\pcb\295\op1b-2016-pcb295.Ddb - 295E\OUTPUT.SCH		

# PCB 295E - MAIN CONTROL BOARD, 10 OF 13, DELAY CIRCUITS

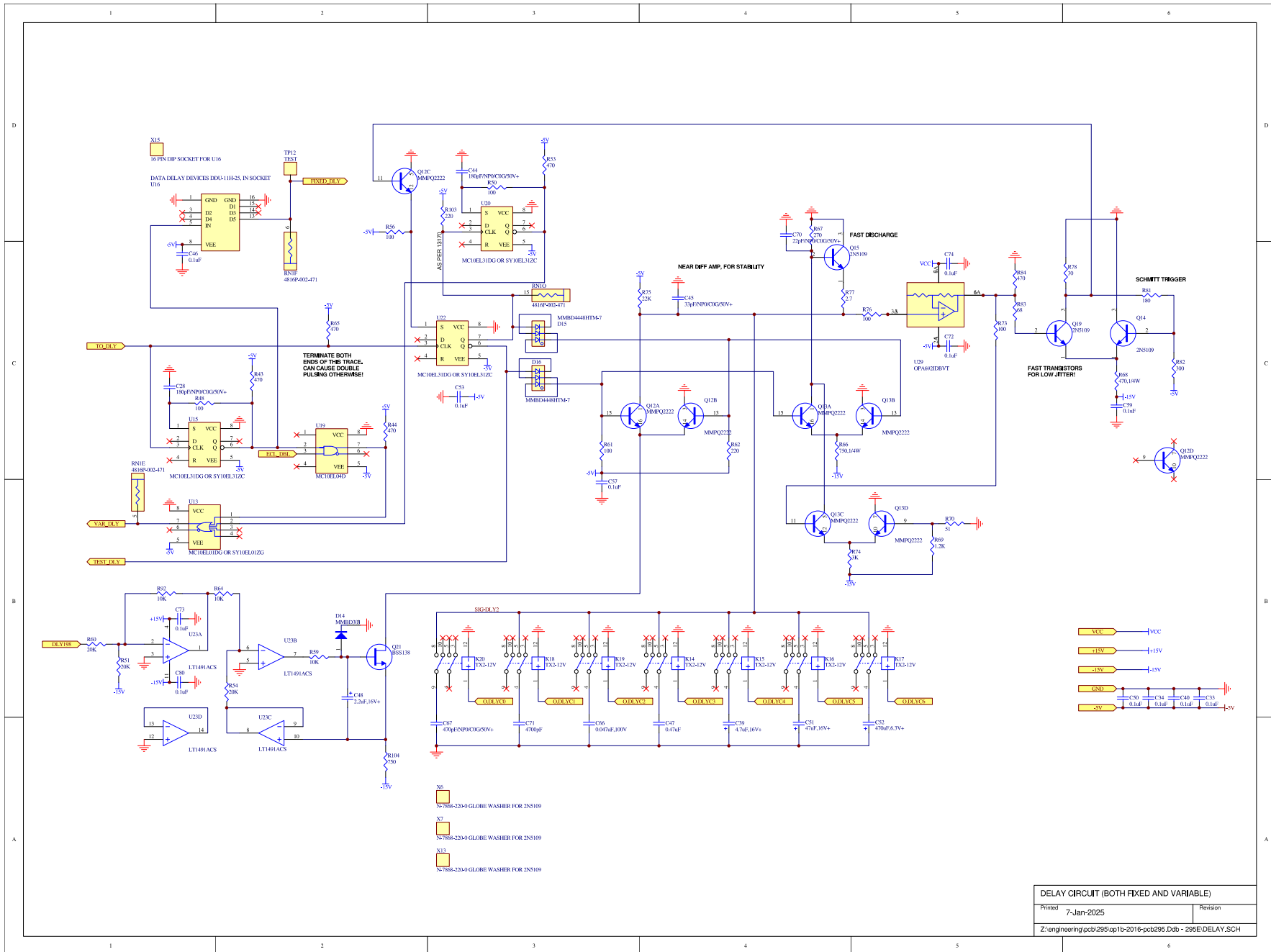

DELAY CIRCUIT (BOTH FIXED AND VARIABLE)	
Printed	7-Jan-2025
Revision	
Z:\engineering\pcb\295\opt-2016-pcb\295.Dwg - 295E.DELAY.SCH	

# PCB 295E - MAIN CONTROL BOARD, 11 OF 13, PULSE WIDTH CIRCUIT

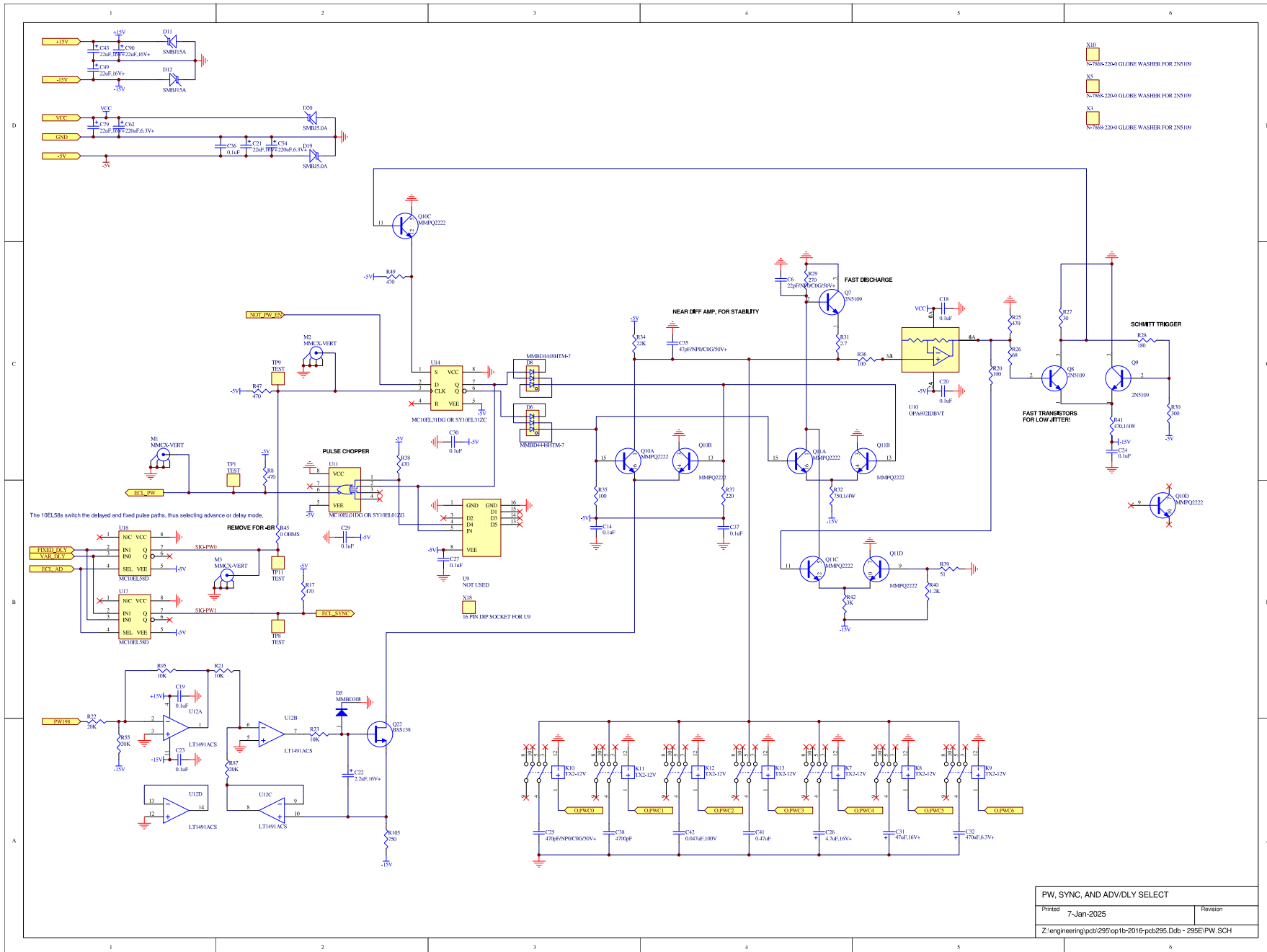

PW, SYNC, AND ADV/DLY SELECT	
Printed	Revision
7-Jan-2025	
Z:\engineering\pcb\295\optb-2016\pcb295.Dcb - 295E.PW.SCH	

# PCB 295E - MAIN CONTROL BOARD, 12 OF 13, TRIGGER SELECT

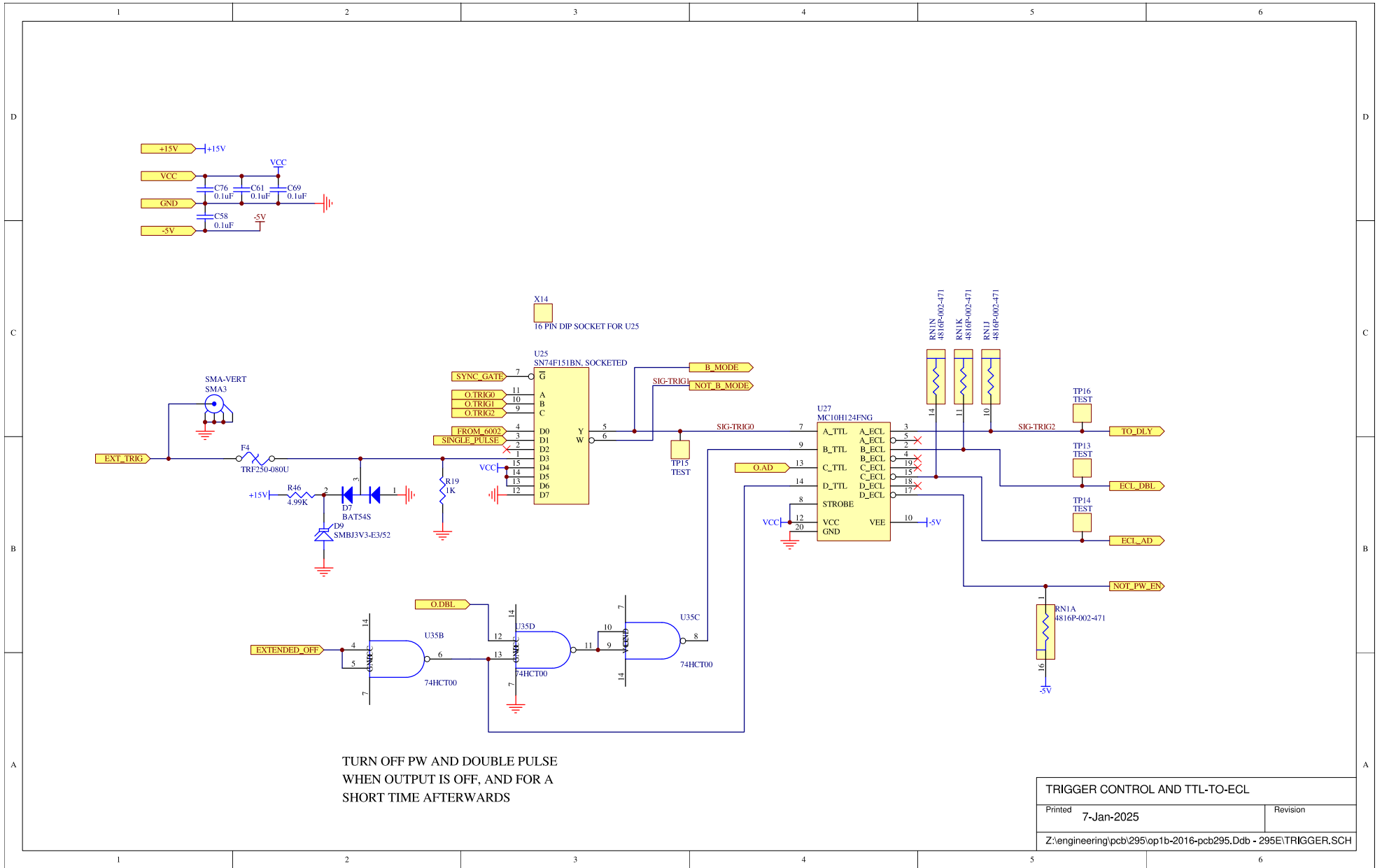

# PCB 295E - MAIN CONTROL BOARD, 13 OF 13, SHIFT REGISTERS

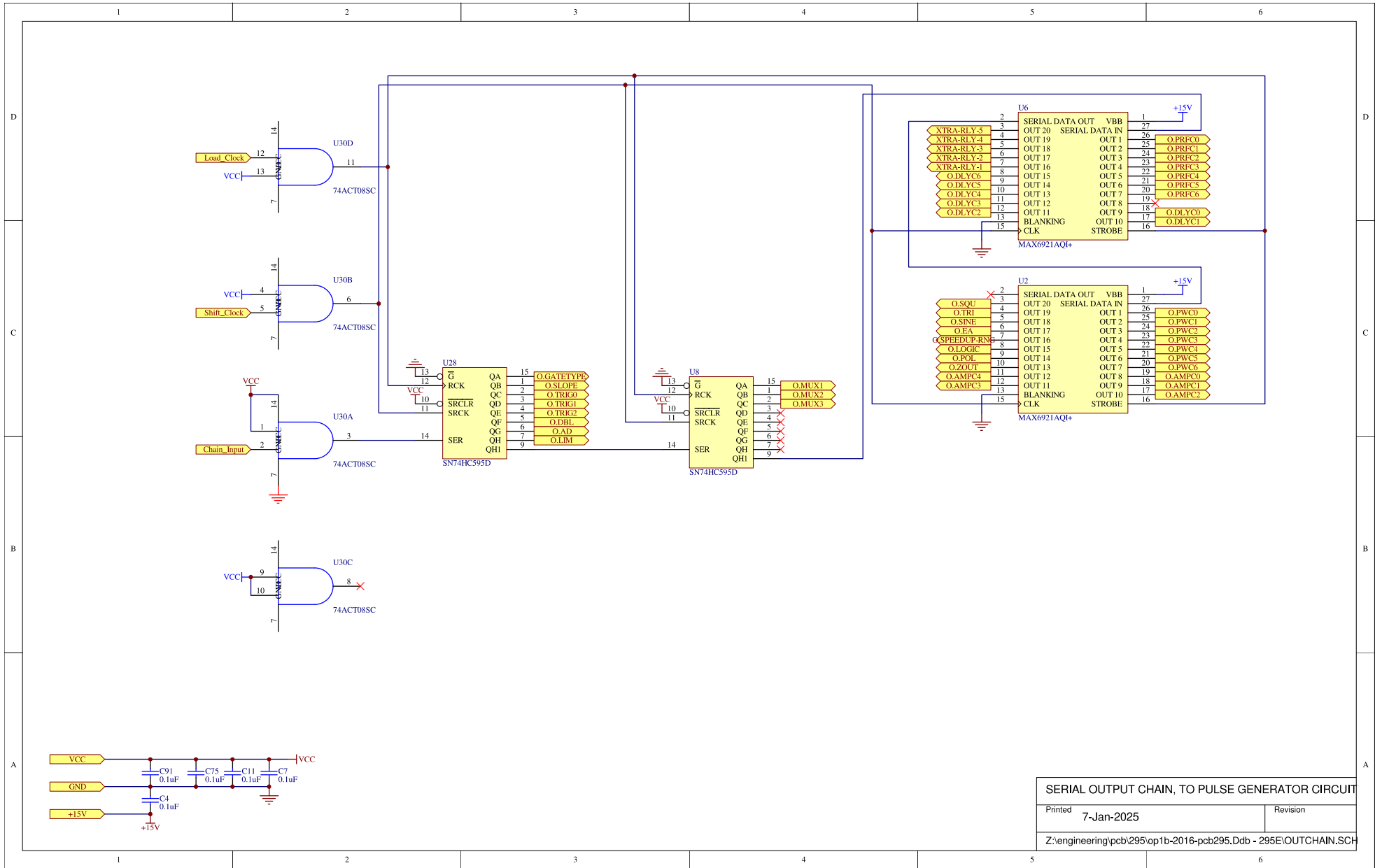

# MAIN WIRING

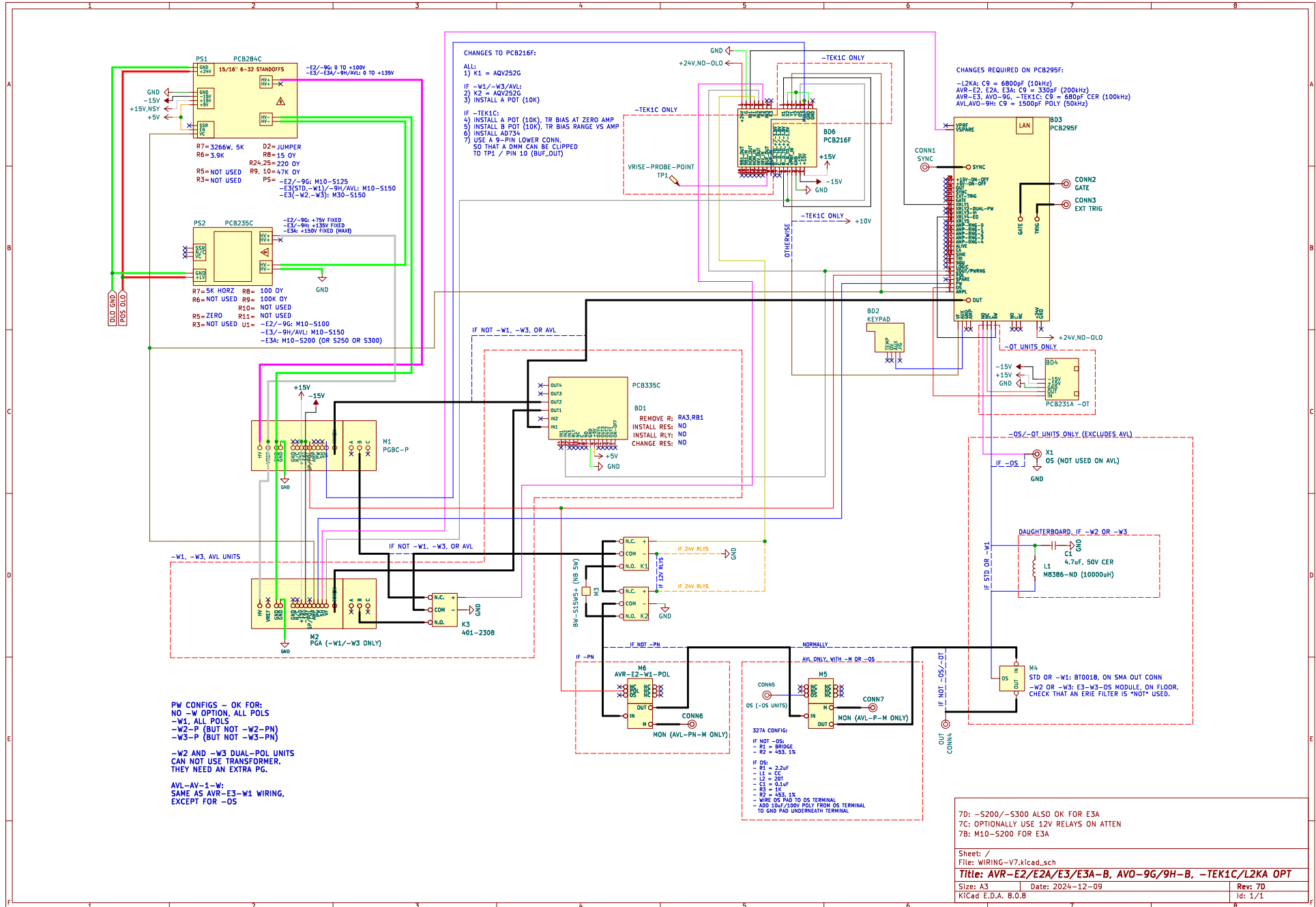

# MAIN WIRING (-PN UNITS WITH -W2 OR -W3 OPTIONS)

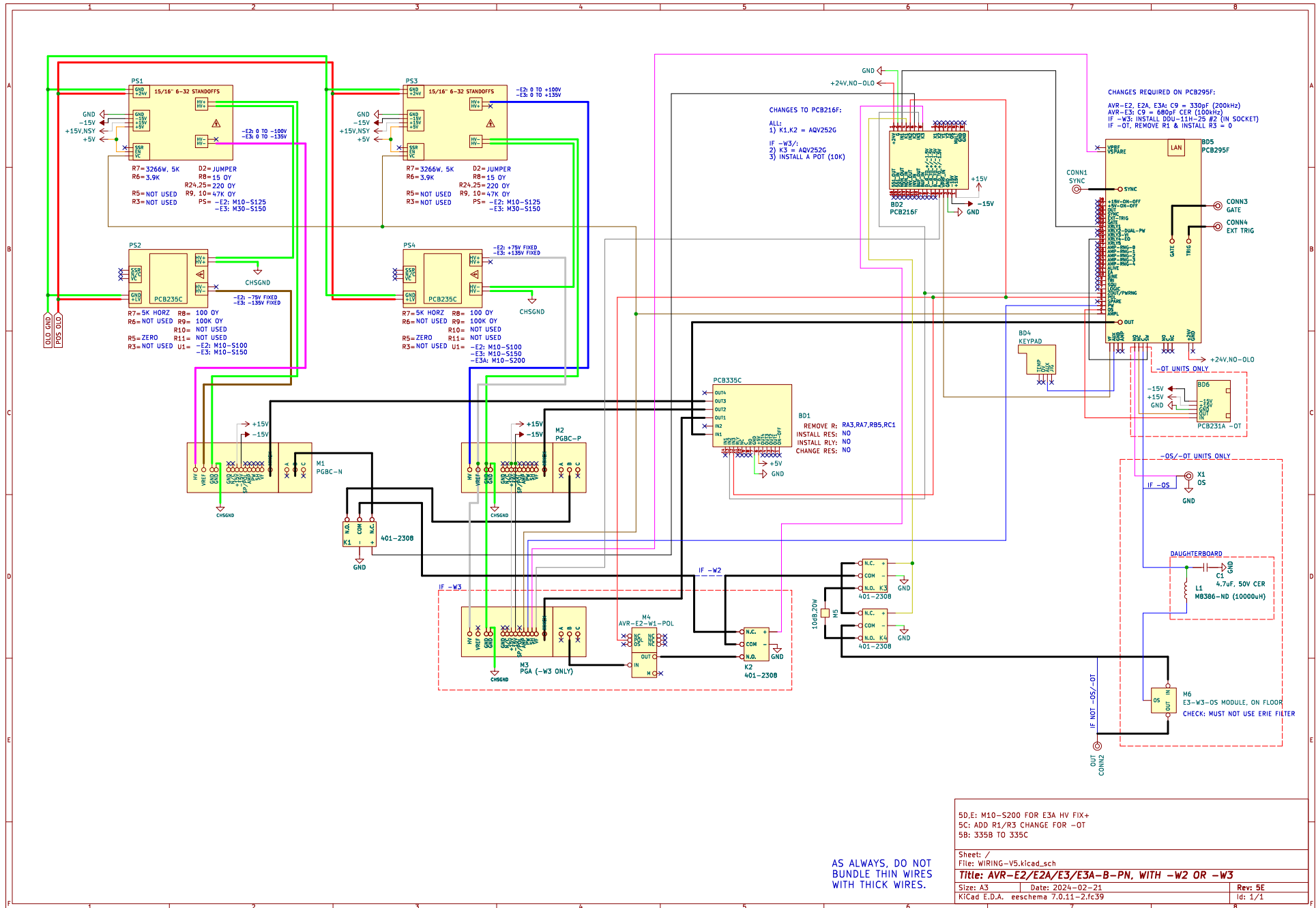



PERFORMANCE CHECKSHEET