



AVTECH ELECTROSYSTEMS LTD.

NANOSECOND WAVEFORM ELECTRONICS
SINCE 1975

P.O. BOX 265
OGDENSBURG, NY
U.S.A. 13669-0265

TEL: 888-670-8729 (USA & Canada) or +1-613-226-5772 (Intl)
FAX: 800-561-1970 (USA & Canada) or +1-613-226-2802 (Intl)

info@avtechpulse.com - <http://www.avtechpulse.com/>

BOX 5120, LCD MERIVALE
OTTAWA, ONTARIO
CANADA K2C 3H4

INSTRUCTIONS

MODEL AVR-EB7-B-DIPFP

+/- 200 mA REVERSE RECOVERY

MEASUREMENT SYSTEM

FOR DIPS AND FLAT-PACKS

SERIAL NUMBER: _____

WARRANTY

Avtech Electrosystems Ltd. warrants products of its manufacture to be free from defects in material and workmanship under conditions of normal use. If, within one year after delivery to the original owner, and after prepaid return by the original owner, this Avtech product is found to be defective, Avtech shall at its option repair or replace said defective item. This warranty does not apply to units which have been disassembled, modified or subjected to conditions exceeding the applicable specifications or ratings. This warranty is the extent of the obligation assumed by Avtech with respect to this product and no other warranty or guarantee is either expressed or implied.

TECHNICAL SUPPORT

Phone: 888-670-8729 (USA & Canada) or +1-613-226-5772 (Intl)

Fax: 800-561-1970 (USA & Canada) or +1-613-226-2802 (Intl)

E-mail: info@avtechpulse.com

World Wide Web: <http://www.avtechpulse.com>

TABLE OF CONTENTS

WARRANTY	2
TECHNICAL SUPPORT	2
TABLE OF CONTENTS	3
INTRODUCTION	6
MODEL NUMBER HISTORY.....	7
SPECIFICATIONS	8
EUROPEAN REGULATORY NOTES	9
EC DECLARATION OF CONFORMITY.....	9
DIRECTIVE 2002/95/EC (RoHS).....	9
DIRECTIVE 2002/96/EC (WEEE).....	9
INSTALLATION	11
VISUAL CHECK.....	11
POWER RATINGS.....	11
CONNECTION TO THE POWER SUPPLY.....	11
PROTECTION FROM ELECTRIC SHOCK.....	12
ENVIRONMENTAL CONDITIONS.....	12
FUSES	14
AC FUSE REPLACEMENT.....	14
DC FUSE REPLACEMENT.....	15
FUSE RATINGS.....	15
FRONT PANEL CONTROLS	16
REAR PANEL CONTROLS	18
TIMING CONTROL	21
BASIC TIMING CONTROL.....	21
TRIGGER MODES.....	23
GATING MODES.....	23
BASIC TEST ARRANGEMENT	24
SETTING THE AMPLITUDE LEVELS.....	26
AMPLITUDE ACCURACY.....	27
INCORRECT ORIENTATION.....	27
TEST JIG MECHANICAL ASPECTS	28
AVX-TRR-DIPFP REAR.....	28

AVX-TRR-DIPFP, FOR DIP PACKAGE TESTS.....	28
AVX-TRR-DIPFP, FOR FLAT-PACK TESTS.....	30
AVX-TRR-SOCK.....	32
TYPICAL RESULTS.....	34
1N4937 RESULTS.....	35
200 mA DIP RESULTS (1N6508).....	37
200 mA FLAT-PACK RESULTS (1N5772).....	39
10 mA DIP RESULTS (1N6511).....	41
10 mA FLAT-PACK RESULTS (1N6100).....	43
PROGRAMMING YOUR PULSE GENERATOR.....	45
KEY PROGRAMMING COMMANDS.....	45
ALL PROGRAMMING COMMANDS.....	46
MECHANICAL INFORMATION.....	48
TOP COVER REMOVAL.....	48
RACK MOUNTING.....	48
ELECTROMAGNETIC INTERFERENCE.....	48
MAINTENANCE.....	49
REGULAR MAINTENANCE.....	49
CLEANING.....	49
WIRING DIAGRAMS.....	50
WIRING OF AC POWER.....	50
PCB 158M - LOW VOLTAGE POWER SUPPLY, 1/3.....	51
PCB 158M - LOW VOLTAGE POWER SUPPLY, 2/3.....	52
PCB 158M - LOW VOLTAGE POWER SUPPLY, 3/3.....	53
PCB 168B - HIGH VOLTAGE DC POWER SUPPLY.....	54
PCB 104D - KEYPAD / DISPLAY BOARD, 1/3.....	55
PCB 104D - KEYPAD / DISPLAY BOARD, 2/3.....	56
PCB 104D - KEYPAD / DISPLAY BOARD, 3/3.....	57
PCB 201B - INTERLOCK CONTROL.....	58
PCB 204-1A – NEGATIVE TIMING CONTROL PCB.....	59
MAIN WIRING.....	60
TEST JIG WIRING (AVX-TRR-DIPFP).....	61
PERFORMANCE CHECK SHEET.....	62

INTRODUCTION

The AVR-EB7-B-DIPFP is a high performance, GPIB and RS232-equipped instrument capable of generating a bipolar waveform into a 50 Ohm resistance. Normally, a diode will be placed in series with this resistance, allowing diode currents of up to +/- 200 mA to be generated.

More specifically, the AVR-EB7-B-DIPFP mainframe generates a 2 us wide forward-bias pulse with amplitude adjustable up to +10V / +200 mA. A negative pulse is superimposed onto the forward pulse 300 ns after the start of the forward pulse. The amplitude of the negative is nominally adjustable up to -20V, for a total output of +10V-20V = -10V or -200 mA. (The negative voltage can actually be adjusted to -28V, to provide some margin for diodes with high effective resistance.) The negative pulse lasts for 100 ns. After that, the output waveform becomes positive again, completing the 2 us forward pulse.

The mainframe output has a forward-to-reverse voltage switching time of < 1 ns, approximately. The speed of the waveform that is actually applied to the DUT depends on the test jig used.

Two test jigs are provided with the mainframe. The AVX-TRR-DIPFP test jig provides 16 pin sockets to accept DIP packages with 0.3" row spacing. A plug-in DIP-to-flat-pack adapter is also provided, to permit testing of military-style flat-packs, again with up to 16 pins. The test jig contains a series of relays, permitting the input and output signals to be switched to any of the 16 pins. The pins may be set from the front panel or by computer command. This jig is suitable for automated testing. However, the parasitic inductance of the pin-switching relays in the AVX-TRR-DIPFP test jig degrades the current switching time to < 4.5 ns and tends to introduce ringing on the output waveform.

The AVX-TRR-SOCK test jig is much simpler. It consists essentially of two coaxial cables terminated with 2 pin sockets. The pin sockets are slid (by hand) onto the two device pins of interest. The simple, low-inductance nature of the AVX-TRR-SOCK allow generation of much "cleaner" waveforms (i.e., less ringing) and faster switching speeds (< 2.5 ns typically).

Both jigs should actually yield similar results for t_{RR} measurements. It is suggested that the AVX-TRR-DIPFP be used for automated testing of multi-diode devices, but that the results be "sanity checked" on a limited basis with the AVX-TRR-SOCK jig.

The AVR-EB7-B-DIPFP includes an internal trigger source, but it can also be triggered or gated by an external source. A front-panel pushbutton can also be used to trigger the instrument.

The AVR-EB7-B-DIPFP features front panel keyboard and adjust knob control of the output pulse parameters along with a four line by 40-character backlit LCD display of the output amplitude, pulse repetition frequency, and delay. The instrument includes memory to store up to four complete instrument setups. The operator may use the front

panel or the computer interface to store a complete “snapshot” of all key instrument settings, and recall this setup at a later time.

This instrument is intended for use in research, development, test and calibration laboratories by qualified personnel.

MODEL NUMBER HISTORY

Models AVR-EB7-B-DIPFP and AVR-EB7-B-DIP-FP-MSD are equivalent. These model numbers may be used interchangeably. The AVR-EB7-B-DIP-FP-MSD was originally developed as a special-order model. It was later added as a standard product in the Avtech catalog, and renamed the “AVR-EB7-B-DIPFP”.

SPECIFICATIONS

Model ¹ :	AVR-EB7-B-DIPFP	
Recovery type:	Reverse recovery	
Intended application:	High-speed small-signal diodes	
Basic waveform:	A positive pulse interrupted by a negative pulse	
Pulse polarity:	-	+
Voltage output ^{2,3,5} (to $R_L = 50\Omega$):	-0.2 to -20V	+0.1 to +10V
Corresponding diode current ^{2,3,5} (approx., depends on V_{BIODE}):	-10 mA to -200 mA	+10 mA to +200 mA
Pulse width (FWHM):	100 ns	300 ns ⁶
Rise times (10%-90%):	< 1 ns at the mainframe output < 4.5 ns at the DUT when installed in the AVX-TRR-DIPFP < 2.5 ns at the DUT when installed in the AVX-TRR-SOCK	< 20 ns
Output impedance during pulse (inside the mainframe):	50 Ohms	
Maximum PRF:	5 kHz	
Delay:	300 ns after start of the positive pulse ⁴	0 to ± 1.0 s, variable
Coaxial cable to test jig (supplied):	60 cm / 2 feet, RG-316 or RG-58C/U.	
Supplied test jigs:	<p>AVX-TRR-DIPFP: Will accommodate DIP packages with up to 16 pins (width = 0.3", pitch = 0.1"). A flat-pack-to-DIP adapter will be provided to accept mil-style flat-packs with up to 16 pins (width < 0.27", pitch = 0.050"). The instrument can be programmed to switch the input and output signals to any pair of pins on the device under test, using a system of internal relays. This is not available as a separate part number.</p> <p>AVX-TRR-SOCK: The AVX-TRR-SOCK test jig is much simpler. It consists essentially of two coaxial cables terminated with 2 pin sockets. The pin sockets are slid (by hand) onto the two device pins of interest. The simple, low-inductance nature of the AVX-TRR-SOCK allows for much cleaner waveforms (i.e., less ringing) and faster switching speeds (comparable to the 1 ns switching time of the mainframe output).</p>	
Mainframe connectors:	BNC	
GPIB and RS-232 control:	Standard on -B units. See http://www.avtechpulse.com/gpib for details.	
Trigger required:	Ext trig mode: + 5 Volts, 10 ns or wider (TTL)	
Gate input	Active high or low, switchable. Suppresses triggering when active.	
Power requirements:	100 - 240 Volts, 50 - 60 Hz	
Dimensions:	H x W x D: 100 mm x 430 mm x 375 mm (3.9" x 17" x 14.8")	
Chassis material:	cast aluminum frame and handles, blue vinyl on aluminum cover plates	
Temperature range:	+5°C to +40°C	

- 1) -B suffix indicates IEEE-488.2 GPIB and RS-232 control of amplitude, pulse width, PRF and delay (see <http://www.avtechpulse.com/gpib>).
- 2) For operation at amplitudes of less than 10% of full-scale, best results will be obtained by setting the amplitude near full-scale and using external attenuators on the output.
- 3) The amplitude settings should not be relied upon for any degree of accuracy, because the dynamics of the device under test can affect the actual generated waveforms. Amplitude settings should always be verified by oscilloscope measurements.
- 4) Thus the diode must come to forward steady-state within 300 ns.
- 5) The diode must have a breakdown voltage exceeding these amplitude limits. Contact Avtech for special arrangements if $I_{MAX} \times 50\Omega > V_{BR}$.
- 6) The full forward pulse width is 2 us, but the reverse pulse is super-imposed on the forward pulse 300 ns after the start of the forward pulse.

EUROPEAN REGULATORY NOTES

EC DECLARATION OF CONFORMITY

We Avtech Electrosystems Ltd.
P.O. Box 5120, LCD Merivale
Ottawa, Ontario
Canada K2C 3H4

declare that this pulse generator meets the intent of Directive 89/336/EEC for Electromagnetic Compatibility. Compliance pertains to the following specifications as listed in the official Journal of the European Communities:

EN 50081-1 Emission

EN 50082-1 Immunity

and that this pulse generator meets the intent of the Low Voltage Directive 72/23/EEC as amended by 93/68/EEC. Compliance pertains to the following specifications as listed in the official Journal of the European Communities:

EN 61010-1:2001 Safety requirements for electrical equipment for measurement, control, and laboratory use



DIRECTIVE 2002/95/EC (RoHS)

This instrument is exempt from Directive 2002/95/EC of the European Parliament and of the Council of 27 January 2003 on the Restriction of the use of certain Hazardous Substances (RoHS) in electrical and electronic equipment. Specifically, Avtech instruments are considered "Monitoring and control instruments" (Category 9) as defined in Annex 1A of Directive 2002/96/EC. The Directive 2002/95/EC only applies to Directive 2002/96/EC categories 1-7 and 10, as stated in the "Article 2 - Scope" section of Directive 2002/95/EC.

DIRECTIVE 2002/96/EC (WEEE)

European customers who have purchased this equipment directly from Avtech will have completed a "WEEE Responsibility Agreement" form, accepting responsibility for WEEE

compliance (as mandated in Directive 2002/96/EC of the European Union and local laws) on behalf of the customer, as provided for under Article 9 of Directive 2002/96/EC.

Customers who have purchased Avtech equipment through local representatives should consult with the representative to determine who has responsibility for WEEE compliance. Normally, such responsibilities will lie with the representative, unless other arrangements (under Article 9) have been made.

Requirements for WEEE compliance may include registration of products with local governments, reporting of recycling activities to local governments, and financing of recycling activities.

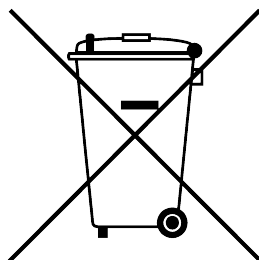

INSTALLATION

VISUAL CHECK

After unpacking the instrument, examine to ensure that it has not been damaged in shipment. Visually inspect all connectors, knobs, liquid crystal displays (LCDs), and the handles. If the instrument has been damaged, file a claim immediately with the company that transported the instrument.

The following items should be with the instrument:

- 1) A power cord.
- 2) A GPIB cable
- 3) Two instrumentation manuals (this manual and the “Programming Manual for -B Instruments”).
- 4) One AVX-TRR-DIPFP test jig (with a hinged lid)
- 5) One AVX-TRR-SOCK test jig (no enclosure)
- 6) One DIP extractor tool
- 7) A 2 meter length of SMA-to-SMA cable.
- 8) A 2 meter DB-25 control cable.

POWER RATINGS

This instrument is intended to operate from 100 - 240 V, 50 - 60 Hz.

The maximum power consumption is 74 Watts. Please see the “FUSES” section for information about the appropriate AC and DC fuses.

This instrument is an “Installation Category II” instrument, intended for operation from a normal single-phase supply.

CONNECTION TO THE POWER SUPPLY

An IEC-320 three-pronged recessed male socket is provided on the back panel for AC power connection to the instrument. One end of the detachable power cord that is supplied with the instrument plugs into this socket. The other end of the detachable power cord plugs into the local mains supply. Use only the cable supplied with the instrument. The mains supply must be earthed, and the cord used to connect the instrument to the mains supply must provide an earth connection. (The supplied cord does this.)

 Warning: Failure to use a grounded outlet may result in injury or death due to electric shock. This product uses a power cord with a ground connection. It must be connected to a properly grounded outlet. The instrument chassis is connected to the ground wire in the power cord.

The table below describes the power cord that is normally supplied with this instrument, depending on the destination region:

Destination Region	Description	Manufacturer	Part Number
Continental Europe	European CEE 7/7 "Schuko" 230V, 50Hz	Qualtek (http://www.qualtekusa.com)	319004-T01
United Kingdom	BS 1363, 230V, 50Hz	Qualtek (http://www.qualtekusa.com)	370001-E01
Switzerland	SEV 1011, 2 30V, 50Hz	Volex (http://www.volex.com)	2102H-C3-10
Israel	SI 32, 220V, 50Hz	Volex (http://www.volex.com)	2115H-C3-10
North America, and all other areas	NEMA 5-15, 120V, 60 Hz	Qualtek (http://www.qualtekusa.com)	312007-01

PROTECTION FROM ELECTRIC SHOCK

 Operators of this instrument must be protected from electric shock at all times. The owner must ensure that operators are prevented access and/or are insulated from every connection point. In some cases, connections must be exposed to potential human contact. Operators must be trained to protect themselves from the risk of electric shock. This instrument is intended for use by qualified personnel who recognize shock hazards and are familiar with safety precautions required to avoid possibly injury. In particular, operators should:

1. Keep exposed high-voltage wiring to an absolute minimum.
2. Wherever possible, use shielded connectors and cabling.
3. Connect and disconnect loads and cables only when the instrument is turned off.
4. Keep in mind that all cables, connectors, oscilloscope probes, and loads must have an appropriate voltage rating.
5. Do not attempt any repairs on the instrument, beyond the fuse replacement procedures described in this manual. Contact Avtech technical support (see page 2 for contact information) if the instrument requires servicing. Service is to be performed solely by qualified service personnel.

ENVIRONMENTAL CONDITIONS

This instrument is intended for use under the following conditions:

1. indoor use;
2. altitude up to 2 000 m;
3. temperature 5 °C to 40 °C;
4. maximum relative humidity 80 % for temperatures up to 31 °C decreasing linearly to 50 % relative humidity at 40 °C;
5. Mains supply voltage fluctuations up to ± 10 % of the nominal voltage;
6. no pollution or only dry, non-conductive pollution.

FUSES

This instrument contains four fuses. All are accessible from the rear-panel. Two protect the AC prime power input, and two protect the internal DC power supplies. The locations of the fuses on the rear panel are shown in the figure below:

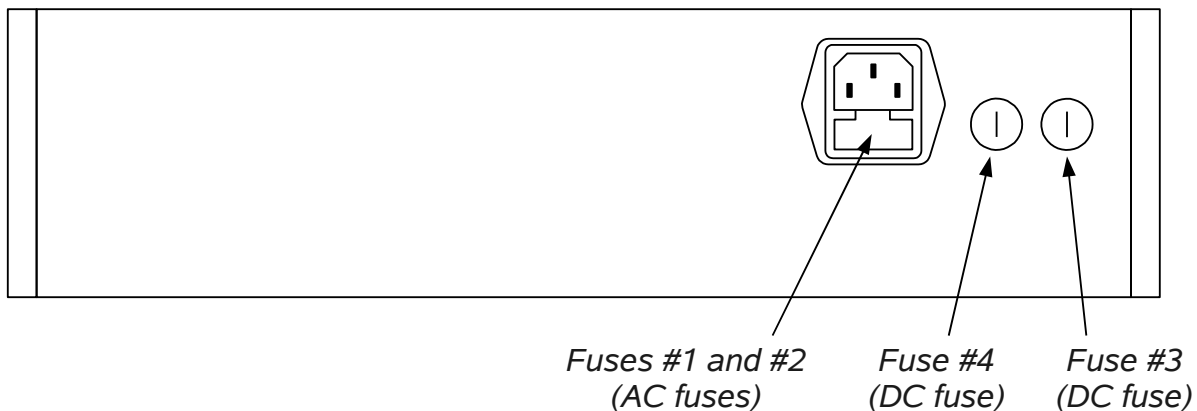

AC FUSE REPLACEMENT

To physically access the AC fuses, the power cord must be detached from the rear panel of the instrument. The fuse drawer may then be extracted using a small flat-head screwdriver, as shown below:

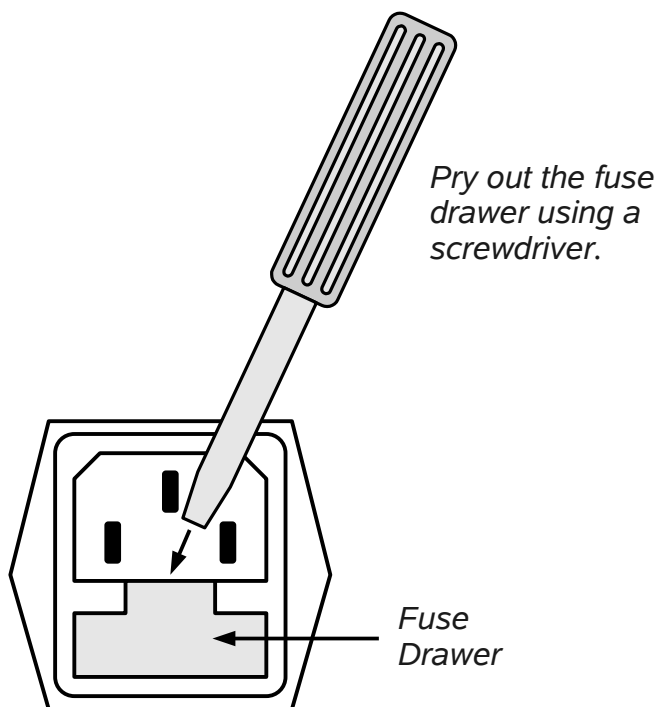

DC FUSE REPLACEMENT

The DC fuses may be replaced by inserting the tip of a flat-head screwdriver into the fuse holder slot, and rotating the slot counter-clockwise. The fuse and its carrier will then pop out.

FUSE RATINGS

The following table lists the required fuses:

Fuses	Nominal Mains Voltage	Rating	Case Size	Manufacturer's Part Number (Wickmann)	Distributor's Part Number (Digi-Key)
#1, #2 (AC)	100-240V	0.5A, 250V, Time-Delay	5×20 mm	1950500000	WK5041-ND
#3 (DC)	N/A	1.6A, 250V, Time-Delay	5×20 mm	1951160000	WK5053-ND
#4 (DC)	N/A	0.5A, 250V, Time-Delay	5×20 mm	1950500000	WK5041-ND

The fuse manufacturer is Wickmann (<http://www.wickmann.com/>).

Replacement fuses may be easily obtained from Digi-Key (<http://www.digikey.com/>) and other distributors.

FRONT PANEL CONTROLS

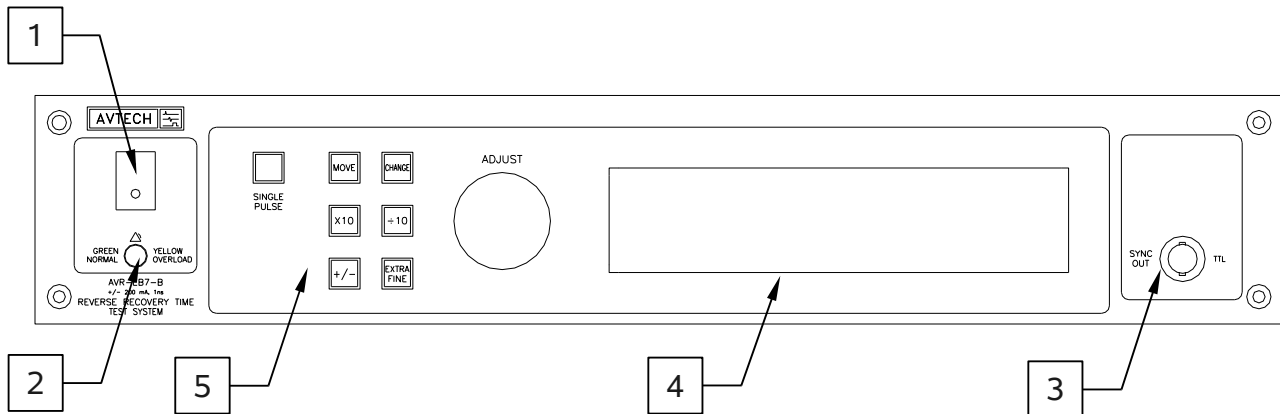

1. POWER Switch. This is the main power switch. When turning the instrument on, there may be a delay of several seconds before the instrument appears to respond.
2. OVERLOAD Indicator. When the instrument is powered, this indicator is normally green, indicating normal operation. If this indicator is yellow, an internal automatic overload protection circuit has been tripped. If the unit is overloaded (by operating at an exceedingly high duty cycle or by operating into a very low impedance), the protective circuit will disable the output of the instrument and turn the indicator light yellow. The light will stay yellow (i.e. output disabled) for about 5 seconds after which the instrument will attempt to re-enable the output (i.e. light green) for about 1 second. If the overload condition persists, the output will be disabled again (i.e. light yellow) for another 5 seconds. If the overload condition has been removed, the instrument will resume normal operation.

This overload indicator may flash yellow briefly at start-up. This is not a cause for concern.
3. SYNC OUT. This connector supplies a SYNC output that can be used to trigger other equipment, particularly oscilloscopes. This signal leads (or lags) the main output by a duration set by the "DELAY" controls and has an approximate amplitude of +3 Volts to $R_L > 50\Omega$ with a pulse width of approximately 100 ns.
4. LIQUID CRYSTAL DISPLAY (LCD). This LCD is used in conjunction with the keypad to change the instrument settings. Normally, the main menu is displayed, which lists the key adjustable parameters and their current values. The "Programming Manual for -B Instruments" describes the menus and submenus in detail.

5. KEYPAD.

Control Name	Function
MOVE	This moves the arrow pointer on the display.
CHANGE	This is used to enter the submenu, or to select the operating mode, pointed to by the arrow pointer.
×10	If one of the adjustable numeric parameters is displayed, this increases the setting by a factor of ten.
÷10	If one of the adjustable numeric parameters is displayed, this decreases the setting by a factor of ten.
+/-	If one of the adjustable numeric parameters is displayed, and this parameter can be both positive or negative, this changes the sign of the parameter.
EXTRA FINE	This changes the step size of the ADJUST knob. In the extra-fine mode, the step size is twenty times finer than in the normal mode. This button switches between the two step sizes.
ADJUST	This large knob adjusts the value of any displayed numeric adjustable values, such as frequency, pulse width, etc. The adjust step size is set by the "EXTRA FINE" button. When the main menu is displayed, this knob can be used to move the arrow pointer.

REAR PANEL CONTROLS

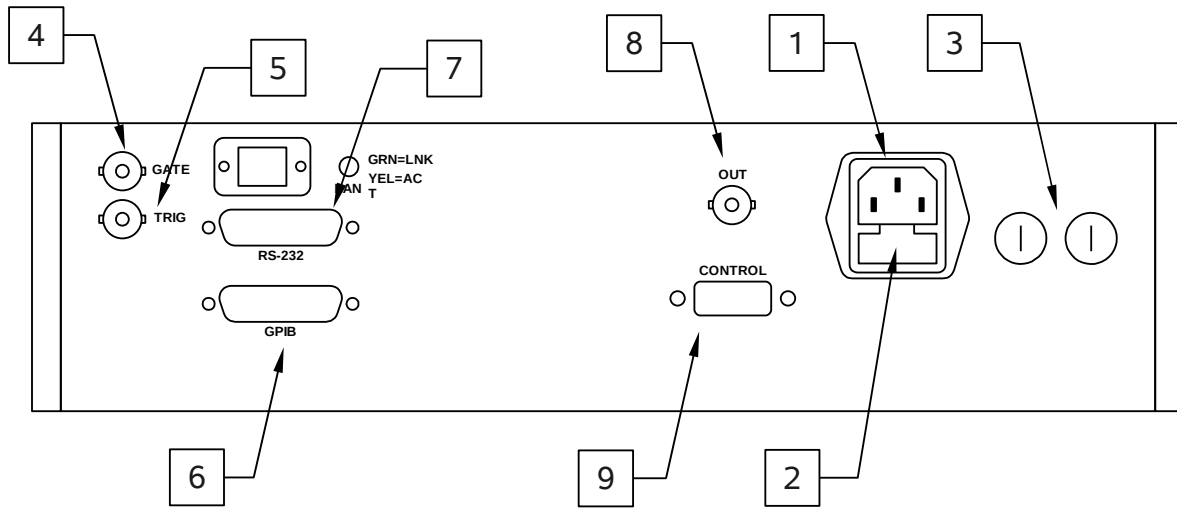

1. **AC POWER INPUT.** An IEC-320 C14 three-pronged recessed male socket is provided on the back panel for AC power connection to the instrument. One end of the detachable power cord that is supplied with the instrument plugs into this socket.
2. **AC FUSE DRAWER.** The two fuses that protect the AC input are located in this drawer. Please see the “FUSES” section of this manual for more information.
3. **DC FUSES.** These two fuses protect the internal DC power supplies. Please see the “FUSES” sections of this manual for more information.
4. **GATE.** This TTL-level (0 and +5V) logic input can be used to gate the triggering of the instrument. This input can be either active high or active low, depending on the front panel settings or programming commands. (The instrument triggers normally when this input is unconnected). When set to active high mode, this input is pulled-down to ground by a 1 k Ω resistor. When set to active low mode, this input is pulled-up to +5V by a 1 k Ω resistor.
5. **TRIG.** This TTL-level (0 and +5V) logic input can be used to trigger the instrument, if the instrument is set to triggering externally. The instrument triggers on the rising edge of this input. The input impedance of this input is 1 k Ω . (Depending on the length of cable attached to this input, and the source driving it, it may be desirable to add a coaxial 50 Ohm terminator to this input to provide a proper transmission line termination. The Pasternack (www.pasternack.com) PE6008-50 BNC feed-thru 50 Ohm terminator is suggested for this purpose.)
6. **GPIB Connector.** A standard GPIB cable can be attached to this connector to allow the instrument to be computer-controlled. See the “Programming Manual for -B Instruments” for more details on GPIB control.

7. RS-232 Connector. A standard serial cable with a 25-pin male connector can be attached to this connector to allow the instrument to be computer-controlled. See the "Programming Manual for -B Instruments" for more details on RS-232 control.
8. OUT CONNECTOR. This SMA connector provides the pulse output signal to the test jig. This output should be connected to the corresponding input on the test jig using the supplied SMA-to-SMA coaxial cable.

The voltages on the OUT connector are not hazardous.

9. CONTROL Connector(s). Depending on the exact configuration of the instrument, one or two "CONTROL" connectors may be present on the back panel.

If just one CONTROL connector is present, it will be a DB-9 female connector.

If two CONTROL connectors are present, one will be a DB-9 female connector and one will be a DB-25 female connector. Only one of the two connectors should be used at a time. Use the one that matches the CONTROL connector on the test jig being used (i.e., DB-9 or DB-25).

The mainframe CONTROL connector should be connected to the corresponding connector on the test jig using the supplied cable. This cable contains the safety interlock signals that ensure that the test jig lid is closed.

For DB-9 cables, the pinout is as follows:

- Pin 1 - To test jig switch 1.
- Pin 2 - To test jig switch 2.
- Pin 3 - N/C.
- Pin 4 - N/C.
- Pin 5 - Ground.
- Pin 6 - To test jig switch 1.
- Pin 7 - To test jig switch 2.
- Pin 8 - N/C.
- Pin 9 - Safety sensor power supply (+15V through 680 Ohms).

When the test jig lid is safely closed, Pin 1 is shorted to Pin 6, and Pin 2 is shorted to Pin 7.

For DB-25 cables, the pinout is as follows:

- Pin 1 - To test jig switch 1.
- Pin 2 - To test jig switch 2.
- Pin 3 - N/C.
- Pin 4 - N/C.
- Pin 5 - Ground.
- Pin 6 - Ground.
- Pin 7 - Ground.

Pin 8 - +5V DC.

Pin 9 - +5V DC.

Pin 10 - pin socket select signal (TTL).

Pin 11 - pin socket select signal (TTL).

Pin 12 - pin socket select signal (TTL).

Pin 13 - pin socket select signal (TTL).

Pin 14 - To test jig switch 1.

Pin 15 - To test jig switch 2.

Pin 16 - N/C.

Pin 17 - Safety sensor power supply (+15V through 680 Ohms).

Pin 18 - N/C.

Pin 19 - Ground.

Pin 20 - +5V DC.

Pin 21 - +5V DC.

Pin 22 - pin socket select signal (TTL).

Pin 23 - pin socket select signal (TTL).

Pin 24 - pin socket select signal (TTL).

Pin 25 - pin socket select signal (TTL).

When the test jig lid is safely closed, Pin 1 is shorted to Pin 14, and Pin 2 is shorted to Pin 15.

TIMING CONTROL

BASIC TIMING CONTROL

This instrument can be triggered by its own internal clock or by an external TTL trigger signal. In either case, two output channels respond to the trigger: OUT and SYNC.

The OUT output is a bipolar signal that may either drive a 50 Ohm load, or the test described later. The positive and negative amplitudes are adjustable. The pulse widths are fixed.

The SYNC pulse is a fixed-width TTL-level reference pulse used to trigger oscilloscopes or other measurement systems. When the delay is set to a positive value the SYNC pulse precedes the PULSE output. When the delay is set to a negative value the SYNC pulse follows the PULSE output.

These pulses are illustrated below, assuming internal triggering and a positive delay:

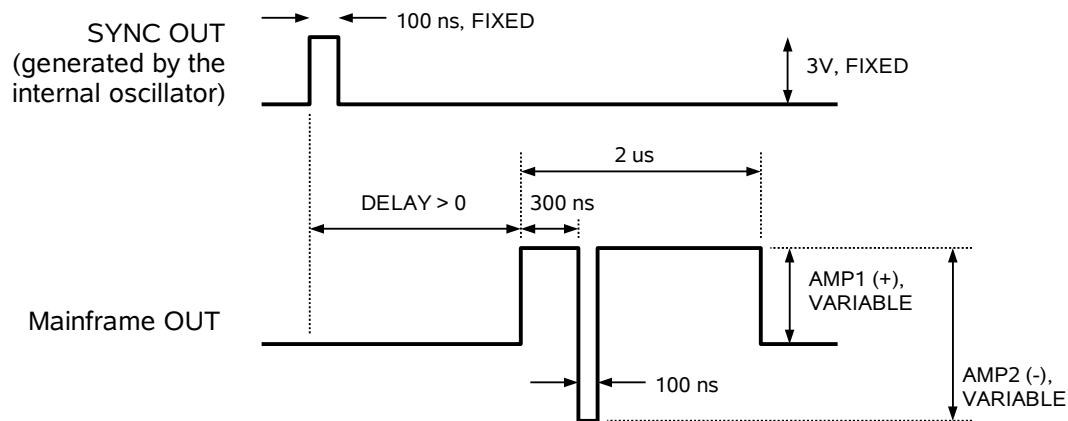

Figure A

If the delay is negative, the order of the SYNC and PULSE outputs is reversed:

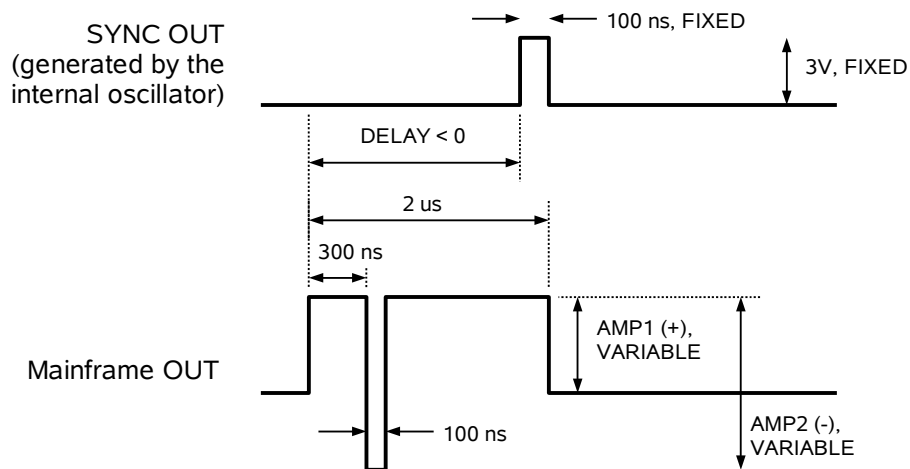

Figure B

The next figure illustrates the relationship between the signal when an external TTL-level trigger is used:

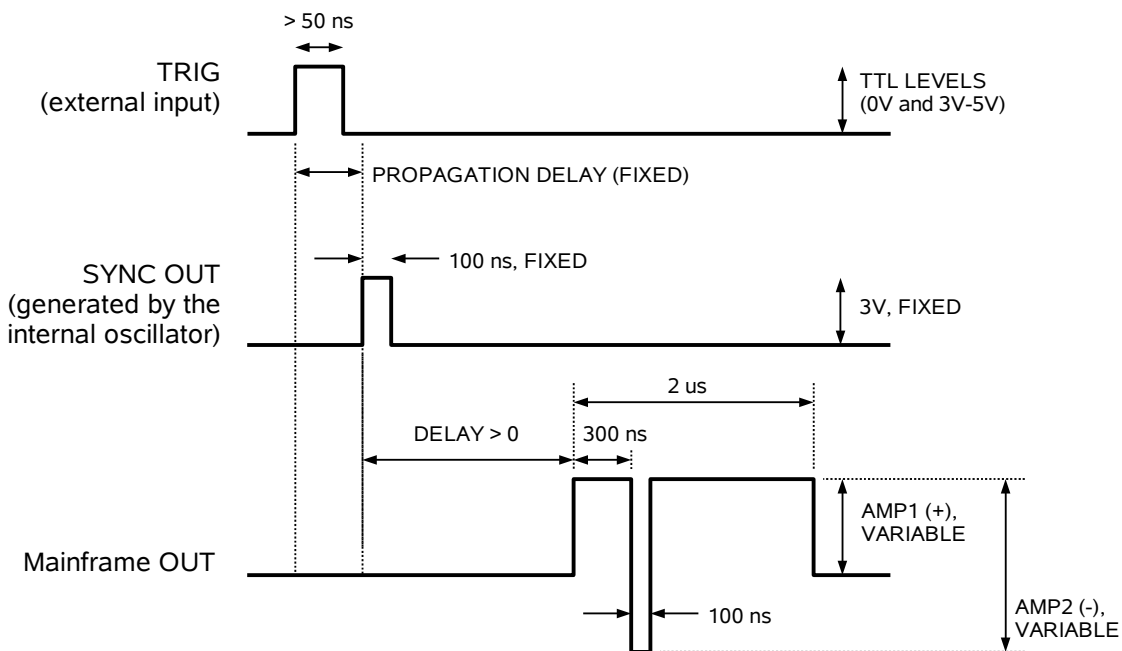

Figure C

As before, if the delay is negative, the order of the SYNC and PULSE outputs is reversed.

The delay and frequency (when in the internal mode) of the PULSE output can be varied with front panel controls or via the GPIB or RS-232 computer interfaces.

TRIGGER MODES

This instrument has four trigger modes:

- Internal Trigger: the instrument controls the trigger frequency, and generates the clock internally.
- External Trigger: the instrument is triggered by an external TTL-level clock on the back-panel TRIG connector.
- Manual Trigger: the instrument is triggered by the front-panel “SINGLE PULSE” pushbutton.
- Hold Trigger: the instrument is set to not trigger at all.

These modes can be selected using the front panel trigger menu, or by using the appropriate programming commands. (See the “Programming Manual for -B Instruments” for more details.)

GATING MODES

Triggering can be suppressed by a TTL-level signal on the rear-panel GATE connector. The instrument can be set to stop triggering when this input high or low, using the front-panel gate menu or the appropriate programming commands. When gated, the output will complete the full pulse width if the output is high, and then stop triggering. Pulses are not truncated.

BASIC TEST ARRANGEMENT

The basic test arrangement for the AVR-EB7-B-DIPFP is shown in the figure below. The OUT output on the instrument mainframe is connected to the IN input on the AVX-TRR-DIPFP test jig using the supplied SMA-to-SMA coaxial cable, and the control cable is connected using the supplied DB-25 cable.

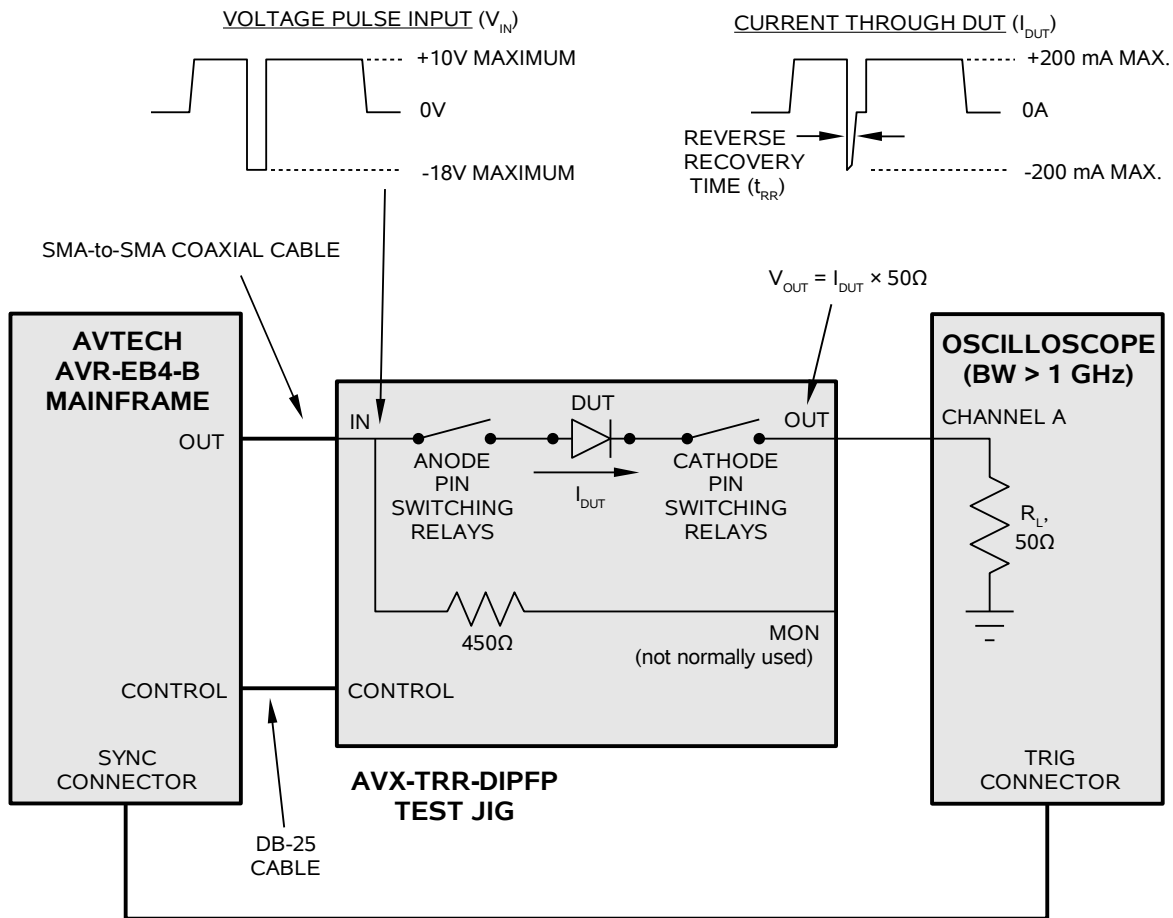

Alternatively, the AVX-TRR-SOCK test jig can be used. In this configuration, the “OUT” output of the mainframe is connected to SMA connector on the AVX-TRR-SOCK jig that leads to the DUT anode. The other SMA connector (connected to the DUT cathode) is fed to the 50 Ohm load and oscilloscope. The CONTROL cable should be left attached to the AVX-TRR-DIPFP, and the lid of the AVX-TRR-DIPFP should be closed. (The CONTROL cable is connected this way since the AVX-TRR-SOCK jig does not have interlock circuitry, but the AVX-TRR-DIPFP does.) This connection scheme is shown below:

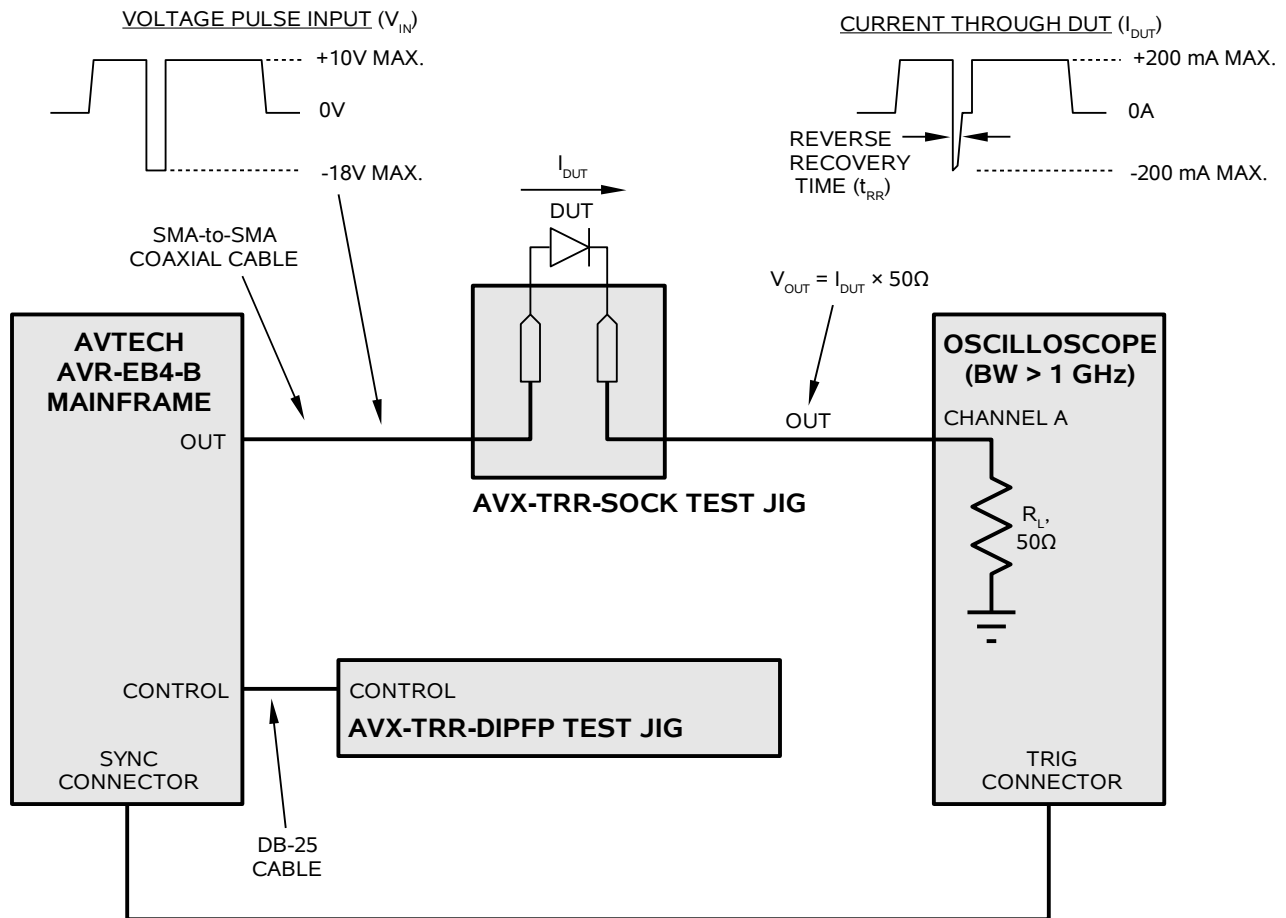

⚠ A 50 Ohm resistance (R_L in the diagram above) must be connected to ground on the output. This can be a discrete resistor, a feed-through terminator, or the input impedance of an oscilloscope. If a high-speed sampling oscilloscope is used, the input should be protected by adding attenuator on the input.

The test jig output voltage is simply given by:

$$V_{OUT} = I_{DUT} \times R_L$$

where I_{DUT} is the current through the device under test and $R_L = 50\Omega$ nominally.

A “MON” output is provided on the AVX-TRR-DIPFP test jig for diagnostic purposes. It is normally not used. If a 50 Ohm resistance to ground is connected to this output, $V_{MON} = V_{IN} / 10$. The additional load presented by the MON circuitry will reduce the output voltage by 10%, approximately.

SETTING THE AMPLITUDE LEVELS

The amplitudes of the positive and negative portions of the mainframe OUT waveform may be set from the front panel of the instrument, or by computer command.

The positive voltage ("AMP1" on the front panel display) is related to the forward diode current by:

$$I_{\text{FORWARD}} \approx (\text{AMP1} - V_F) / (50\Omega + R_{\text{DIODE-FORWARD}})$$

where V_F is the forward voltage drop of the diode (typically 0.7V for the classic silicon PN junction diode, and usually somewhat lower for a Schottky diode), and $R_{\text{DIODE-FORWARD}}$ is the effective resistance of the diode under forward bias.

The negative voltage ("AMP2" on the front panel display) is related to the reverse diode current by:

$$I_{\text{REVERSE}} \approx (\text{AMP1} + \text{AMP2}) / (50\Omega + R_{\text{DIODE-REVERSE}}).$$

Where $R_{\text{DIODE-REVERSE}}$ is the effective resistance of the diode under reverse bias.

 The reverse current is controlled by the sum of the two amplitudes, not by just the negative voltage. For instance, if AMP1 = +10V, then AMP2 must be more negative than -10V to generate a negative current.

For example, to generate a +100 mA forward current and a -200 mA reverse current into an ideal diode with $V_F = 0.7\text{V}$, you would set AMP1 = +5.7V and AMP2 = -15.7V, so that $(+5.7\text{V} - 0.7\text{V}) / 50 \text{ Ohms} = + 100 \text{ mA}$ and $(+5.7\text{V} + (-15.7\text{V})) / 50 \text{ Ohms} = - 200 \text{ mA}$.

It is important to note that $R_{\text{DIODE-FORWARD}}$ and $R_{\text{DIODE-REVERSE}}$ are not the same, and that they may change during the transient. Furthermore, depending on the design of the diode under test, it is possible that $R_{\text{DIODE-REVERSE}}$ may be so high that it is impossible to achieve the full -200 mA of reverse current. (The ideal diode would of course have $R_{\text{DIODE-REVERSE}} = \infty$). The AMP2 voltage can actually be increased to -28V (rather than the nominal maximum of -20V) to increase the likelihood of obtaining the full -200 mA of reverse current.

 At low test currents (~ 10 mA), the I-V curve of the diode will normally be highly nonlinear, and the required negative voltage may not be well-predicted by the above equations. The user will normally need to adjust the voltage amplitudes based on the actual measured output currents, especially for low current levels.

Most test procedures for measuring recovery time will use a particular ratio of forward to reverse currents - for example, $I_{\text{REVERSE}} / I_{\text{FORWARD}} = 2$.

AMPLITUDE ACCURACY

 Due to the variations in V_F and $R_{\text{DIODE-FORWARD}}$ and $R_{\text{DIODE-REVERSE}}$ as a function of operating conditions, the AMP1 and AMP2 settings *should not be relied upon for any degree of accuracy*. Instead the voltage at the OUT terminal on the test jig *must* be monitored with a calibrated oscilloscope. As mentioned above, $I_{\text{DUT}} = V_{\text{OUT}} / R_L$. The user is responsible for establishing the accuracy of R_L .

INCORRECT ORIENTATION

The instrument and the DUT will not be damaged if the diode is installed with the incorrect orientation (i.e., with the anode and cathode reversed). However, incorrect waveforms will be generated.

The AVR-EB7-B does not generate any hazardous voltages on the outputs.

TEST JIG MECHANICAL ASPECTS

AVX-TRR-DIPFP REAR

The IN, MON, OUT, and CONTROL connectors are on the rear of the jig, below the hinges:



AVX-TRR-DIPFP, FOR DIP PACKAGE TESTS

The AVX-TRR-DIPFP can be used to test DIP packages or military-style flat-packs. When testing DIP packages, the DIP-to-flat-pack adapter is removed. The basic test jig is shown below:

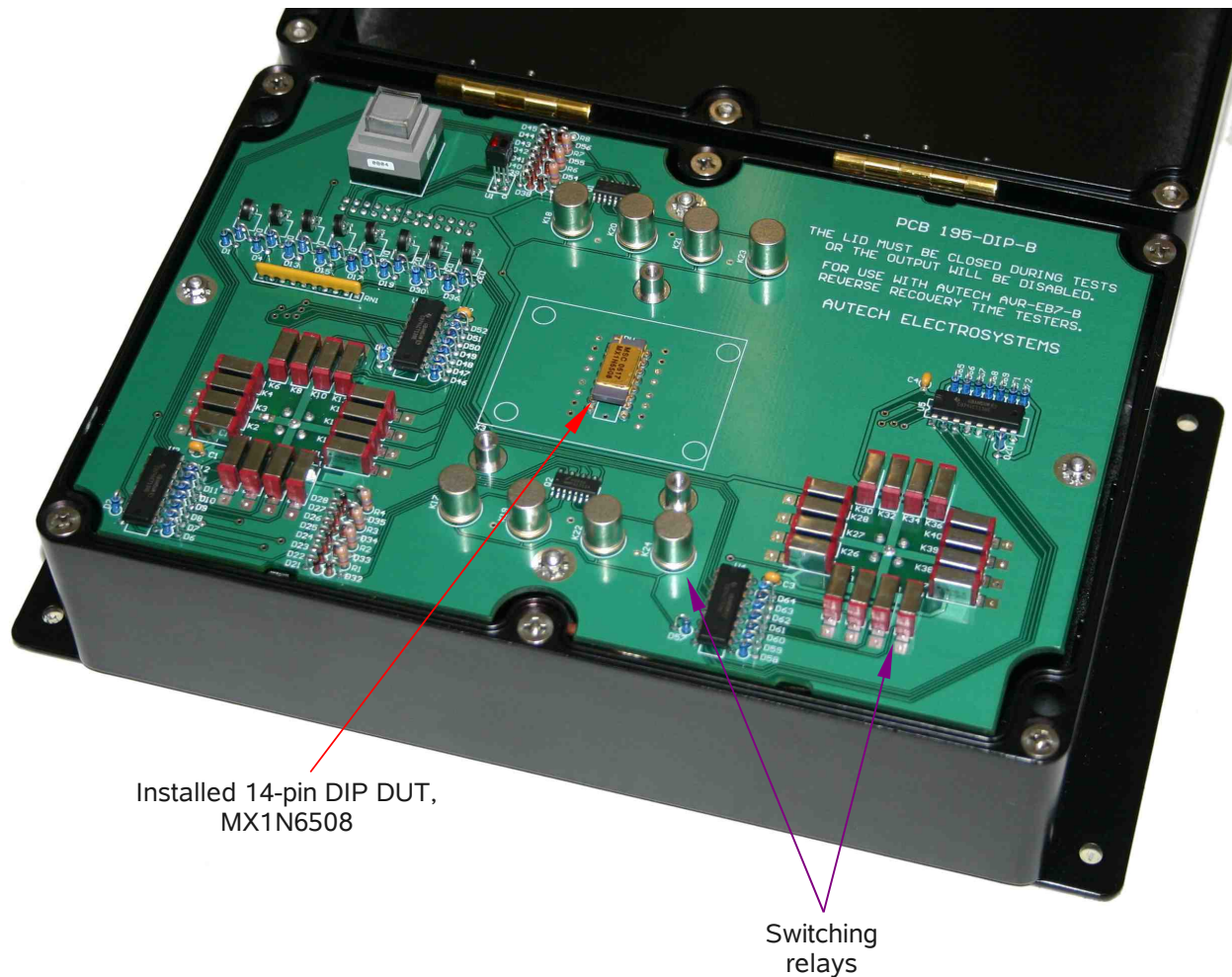

Installed 14-pin DIP DUT,
MX1N6508

Switching
relays

The device under test (DUT) is installed in the array of 16 pin sockets in the middle of the PCB. Pin 1 is towards the rear of the jig (the hinged side). A DIP extractor tool is provided to assist in removing installed DUTs.

The jig contains a very large number of relays and (hidden) coaxial cables for switching signals between the 16 pins. These relays are controlled from the front panel by the “Anode” and “Cathode” menus. These menus should be used to select the diode of interest inside the DIP package.

Computer commands can also be used to select the pins of interest. For instance, if you wish to test a diode which has its anode on pin 4 and its cathode on pin 8, send these two commands:

```
route:close (@anod(4))
route:close (@cath(8))
```

The brackets and the “@” symbol are mandatory (as specified by SCPI, “Standard Commands for Programmable Instrumentation”).

The pin socket array will accept DIP packages with up to 16 pins. If your DUT has fewer than 16 pins, install the DUT such that pin 1 is towards the rear of the jig (the hinged side). The pin numbering used in the Anode and Cathode menus (and the route:close command) is based on the 16 pin package. You will need to adjust for this when using non-16-pin packages. For instance, if you insert an 8 pin DIP, pins 1-8 of the package will actually be installed in pin sockets 1-4 and 13-16.

AVX-TRR-DIPFP, FOR FLAT-PACK TESTS

A DIP-to-flat-pack adapter can be installed in the AVX-TRR-DIPFP to allow it to accept military-style flat-packs with up to 16 pins. The adapter has a clamshell-socket for the flat-pack on top, and 16 pins on the bottom. The 16 pins insert into the 16 pin sockets on the AVX-TRR-DIPFP (that is, where a DIP DUT would go).

To install the adapter, gently insert the 16 pins into the 16 pin sockets, and then secure the adapter using the 3 supplied 4-40 thumbscrews, as shown below.

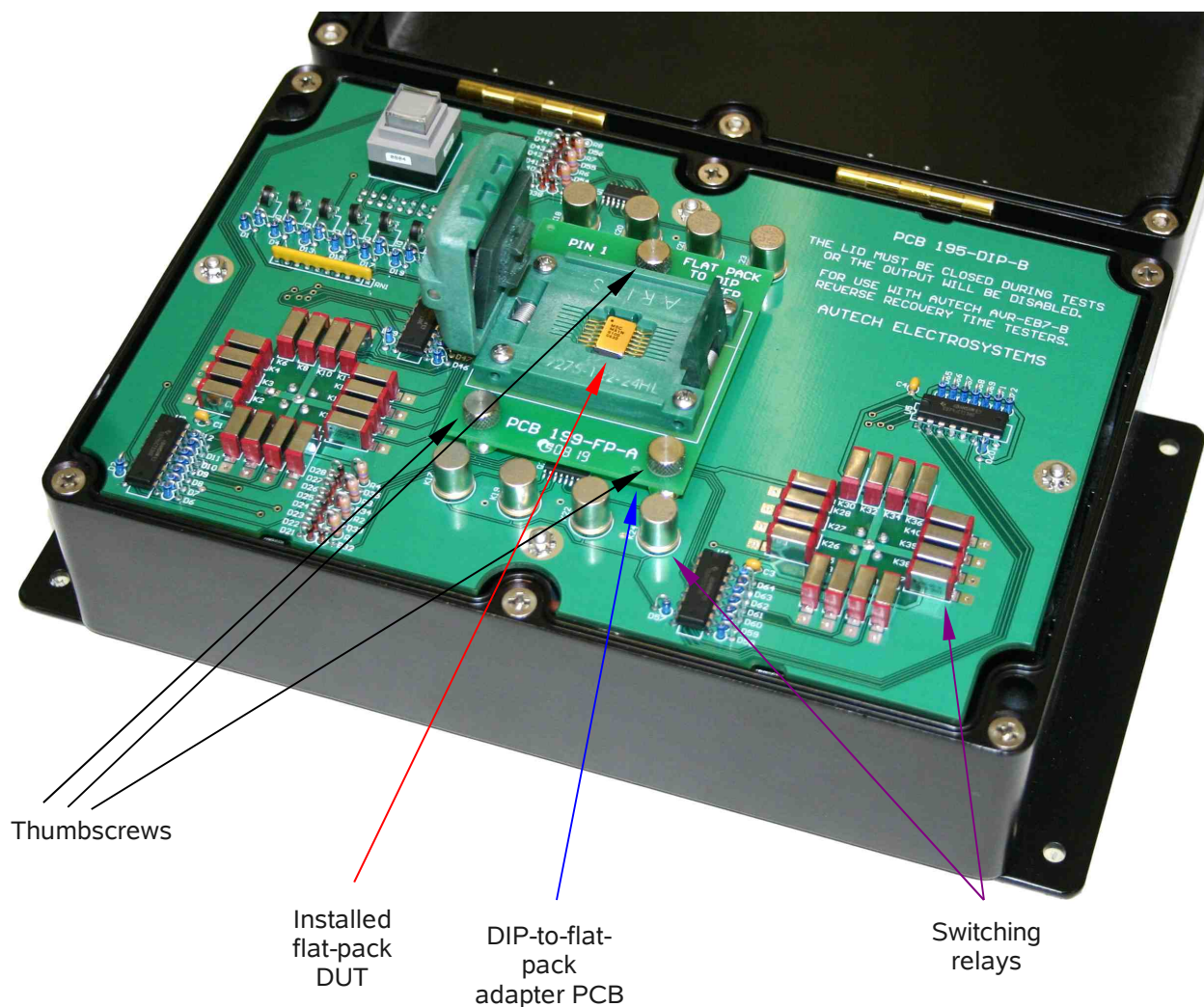

The adapter will accept flat-packs with up to 16 pins. If your DUT has fewer than 16 pins, install the DUT such that pin 1 is towards the rear of the jig (the hinged side). The pin numbering used in the Anode and Cathode menus (and the route:close command) is based on the 16 pin package. You will need to adjust for this when using non-16-pin packages. For instance, if you insert an 8 pin DIP, pins 1-8 of the package will actually be installed in pin sockets 1-4 and 13-16.

Note that the clamshell has a “rocker” bracket on the top, to assist in positioning the DUT inside the clamshell socket. When the clamshell is closed, the rocker bracket presses the flat-pack pins against an array of miniature vertical spring pins, to make electrical contact. The electrical paths are very short.

Once the DUT is installed inside the open clamshell, the clamshell must be latched shut:

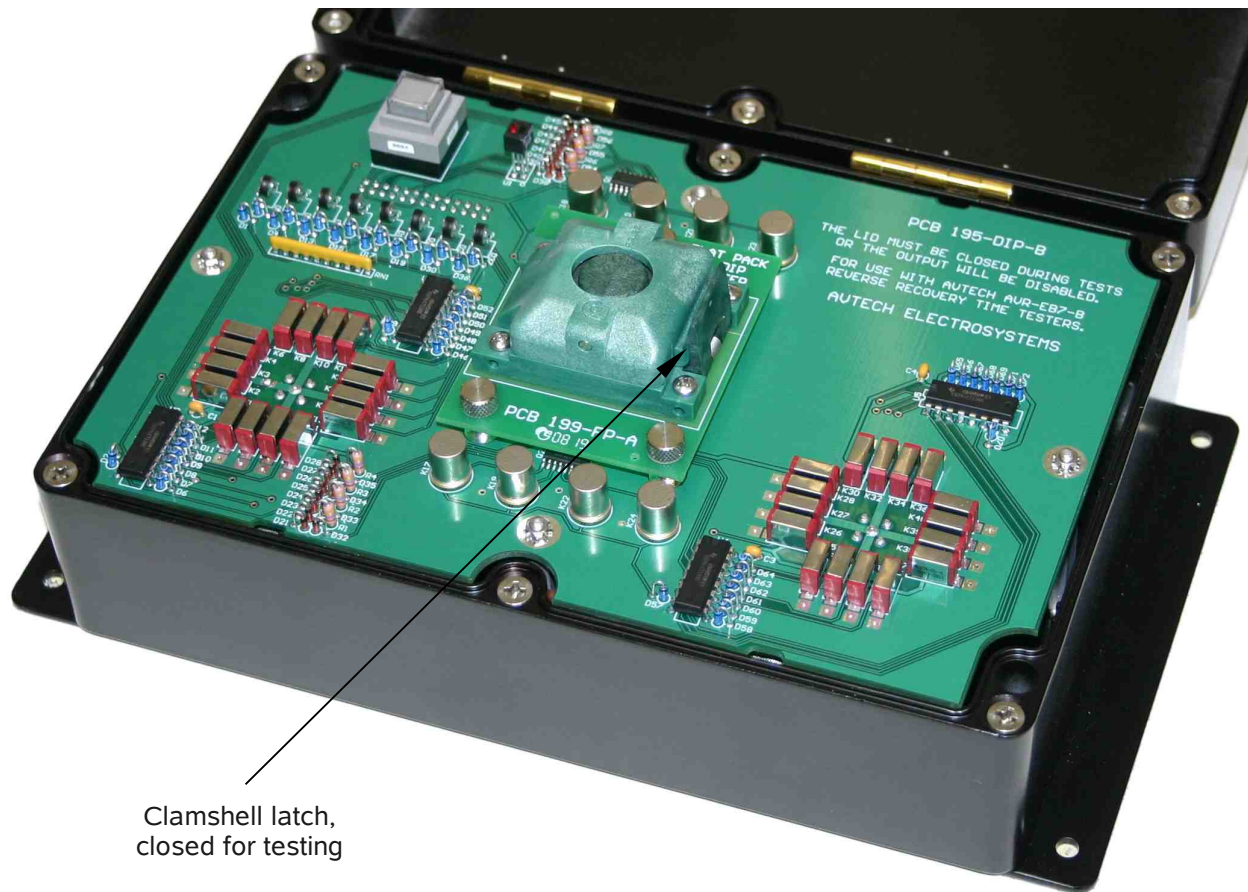

Clamshell latch,
closed for testing

The main black hinged lid must also be closed to enable the output.

The procedure for controlling the active pins is the same as described in the previous section (for DIP packages).

AVX-TRR-SOCK

The AVX-TRR-SOCK test jig is much simpler than the AVX-TRR-DIPFP. It consists essentially of two coaxial cables terminated with 2 pin sockets. The pin sockets are slid (by hand) onto the two device pins of interest. The simple, low-inductance nature of the AVX-TRR-SOCK allows for much cleaner waveforms (i.e., less ringing) and faster switching speeds (comparable to the 1 ns switching time of the mainframe output). It is shown below:

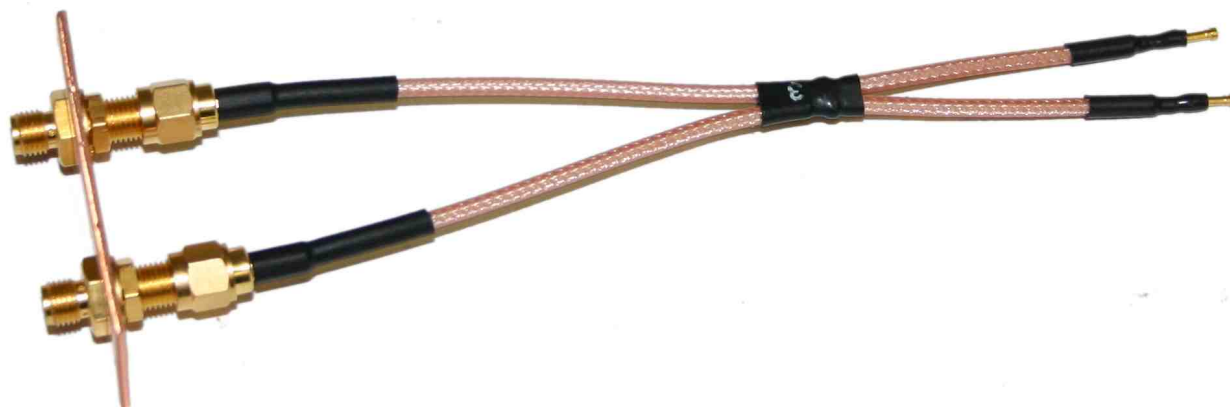

The two “arms” of the AVX-TRR-SOCK are identical – either connector / pin socket pair can be used to connect to the anode or cathode.

The pin sockets slide onto the device pins of interest. Be gentle. The photo below shows connections to pins 1 and 14 of a 14-pin DIP package:



The flat-pack-to-DIP adapter can be used similarly:

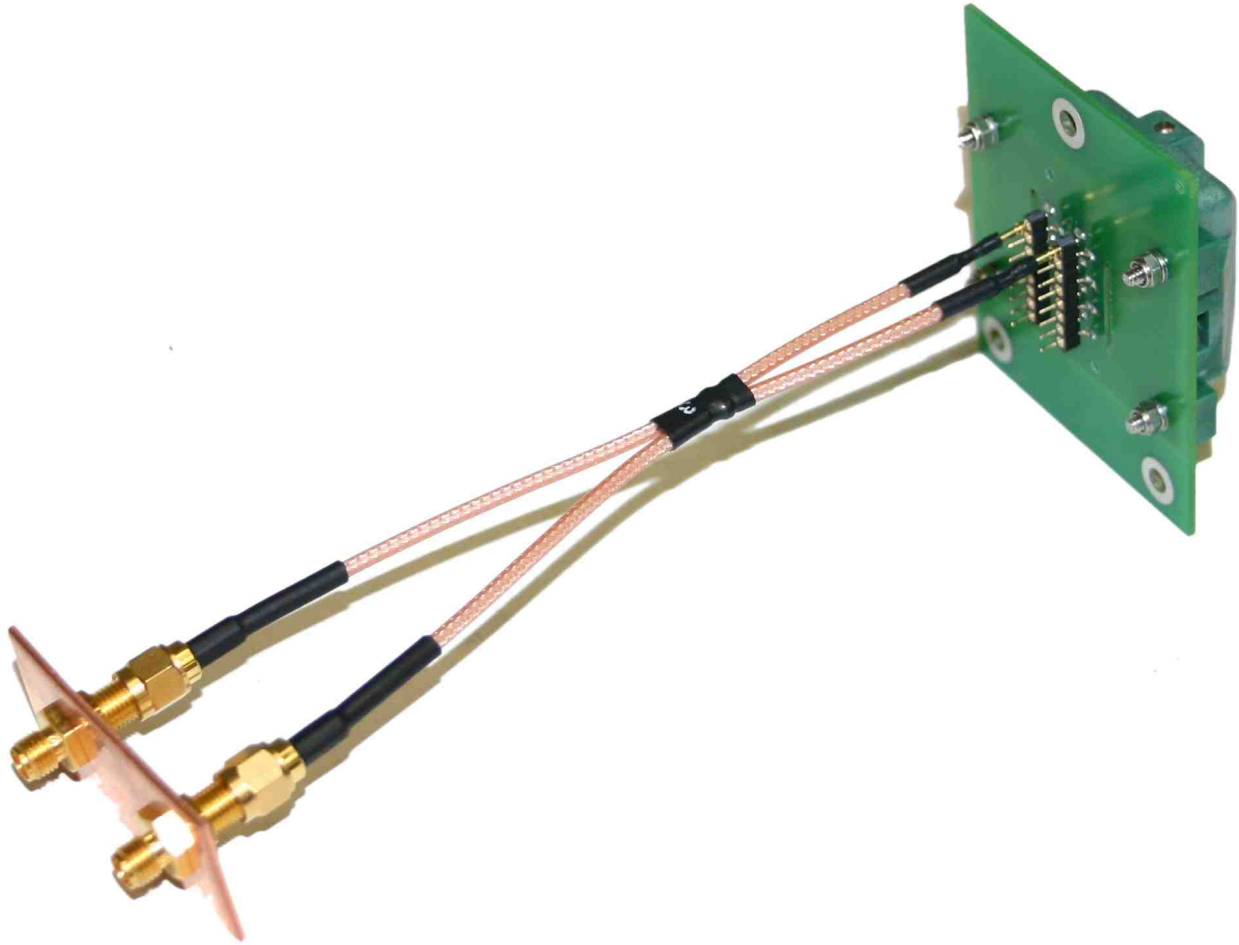

The AVX-TRR-SOCK generates better waveforms than the AVX-TRR-DIPFP, but it is not well suited for automated measurements. The differing results are discussed in the next section.

TYPICAL RESULTS

Obtaining meaningful results with the AVR-EB7-B-DIPFP requires care, experience, and an understanding of diode transient behavior and the impact of inductive and capacitive parasitics. To assist the user, typical results for commercially available diodes are provided below. The user should be able to reliably duplicate these results.

The waveforms in this section were generated using a Tektronix 11801C sampling oscilloscope with 20 or 40 dB of attenuation, as appropriate. The bandwidth of the oscilloscope is 18 GHz.

1N4937 RESULTS

The DIP and flat-pack devices tested later in this section are so fast that the waveforms are difficult to understand. To compensate for this, the first device tested was actually a 1N4937 axial-leaded device, with its leads bent and trimmed. The anode was inserted into pin socket 16, and the cathode was inserted into pin socket 1.

The On Semiconductor 1N4937 is a 1A, 600V DO-41 fast-recovery rectifier. With the amplitudes set to +5.3V and -16.2V to obtain $I_F = +100$ mA and $I_R = -200$ mA, the following reverse recovery waveform is obtained at the test jig "OUT" terminal of the AVR-TRR-DIPFP jig:

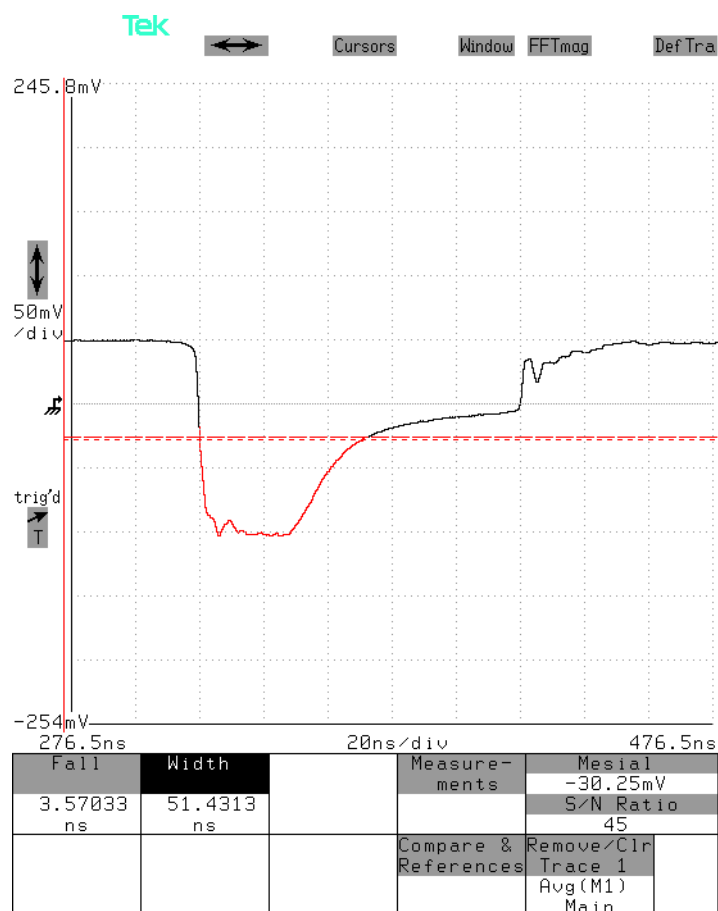

5 V/div (= 100 mA/div), 20 ns/div.
10%-90% switching time shown. AVX-TRR-DIPFP, S/N 11999.

The above waveform shows the transition from a forward current of +0.1A to a reverse current of -0.2A. The reverse transient lasts for approximately 51 ns under these conditions (measured at the 25% reverse current point).

If the AVX-TRR-SOCK is used instead, the results are basically the same, except that the switching times are visibly faster:

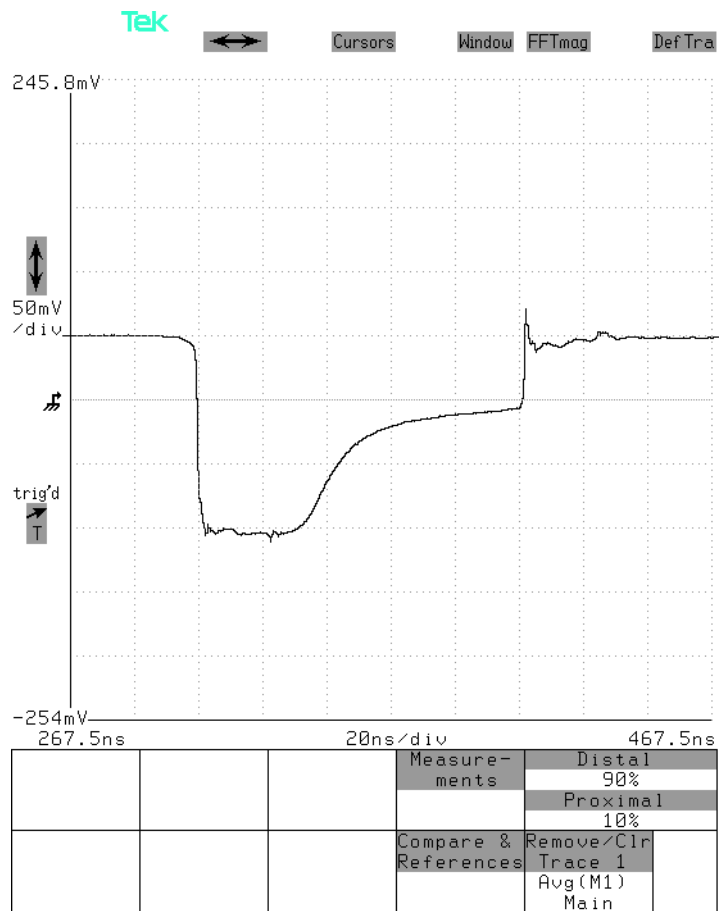

5 V/div (= 100 mA/div), 20 ns/div.
 AVX-TRR-SOCK, S/N 11999.

200 mA DIP RESULTS (1N6508)

The Microsemi 1N6508 DIP-packaged device was tested with amplitudes set to +10V and -28V. Pin socket 2 was used as the anode, and pin socket 1 was used as the cathode. The following reverse recovery waveform was obtained at the test jig "OUT" terminal of the AVR-TRR-DIPFP jig:



5 V/div (= 100 mA/div), 10 ns/div.
AVX-TRR-DIPFP, S/N 11999.

The above waveform shows the transition from a forward current of +200 mA to a reverse current of -200 mA. The reverse recovery transient is extremely fast and sharp. The parasitic inductance in the circuit causes some ringing after the transient.

The main reverse transient is approximately 5 ns in duration, far exceeding the 20 ns figure specified in MIL-PRF-19500/474F for this device.

The ringing is undesirable, but unavoidable with the AVX-TRR-DIPFP. However, we can use the AVX-TRR-SOCK to confirm that the results are still valid. Using the AVX-TRR-SOCK to test the same two pins, with amplitudes of +10V and -20V, generates this waveform:

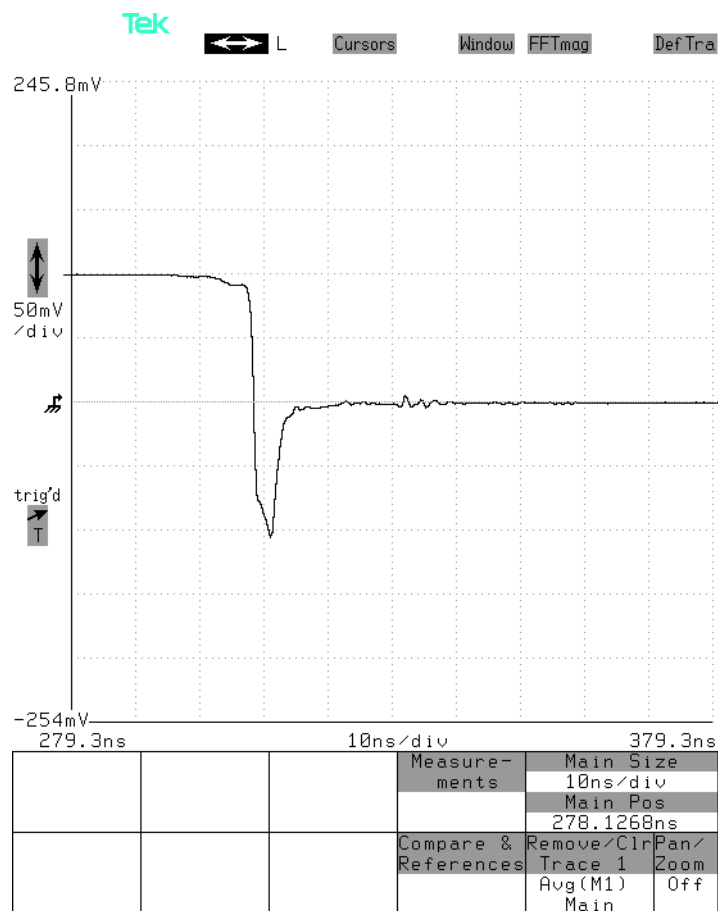

5 V/div (= 100 mA/div), 20 ns/div.
AVX-TRR-SOCK, S/N 11999.

The AVX-TRR-SOCK shows no significant ringing. The duration of the reverse recovery transient is similar to that obtained from the AVX-TRR-DIPFP jig (ignoring the trailing ringing).

The lower inductance of the AVX-TRR-SOCK jig means that a somewhat lower negative voltage is needed to generate the desired current (i.e, less inductive voltage must be overcome).

200 mA FLAT-PACK RESULTS (1N5772)

The Microsemi 1N5772 10-pin flat-pack device was tested with amplitudes set to +10V and -28V. Pin socket 1 was used as the anode, and pin socket 2 was used as the cathode. The following reverse recovery waveform was obtained at the test jig "OUT" terminal of the AVR-TRR-DIPFP jig:

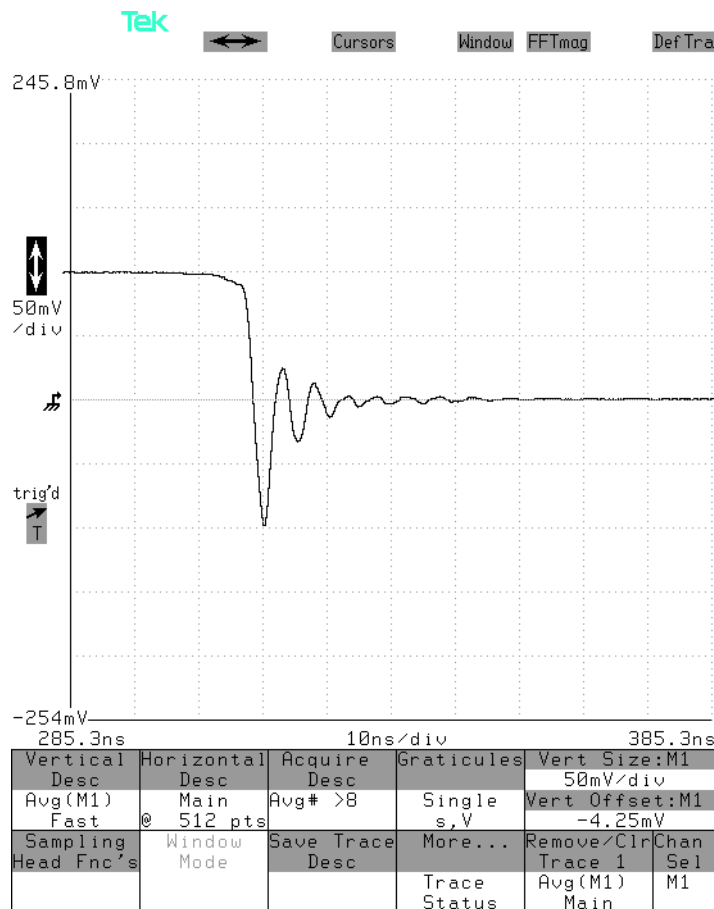

5 V/div (= 100 mA/div), 10 ns/div.
AVX-TRR-DIPFP, S/N 11999.

The above waveform shows the transition from a forward current of +200 mA to a reverse current of -200 mA. The reverse recovery transient is extremely fast and sharp. The parasitic inductance in the circuit causes some ringing after the transient.

The main reverse transient is approximately 5 ns in duration, far exceeding the 20 ns figure specified in MIL-PRF-19500/474F for this device.

The ringing is undesirable, but unavoidable with the AVX-TRR-DIPFP. However, we can use the AVX-TRR-SOCK to confirm that the results are still valid. Using the AVX-TRR-SOCK to test the same two pins, with amplitudes of +10V and -20V, generates this waveform:

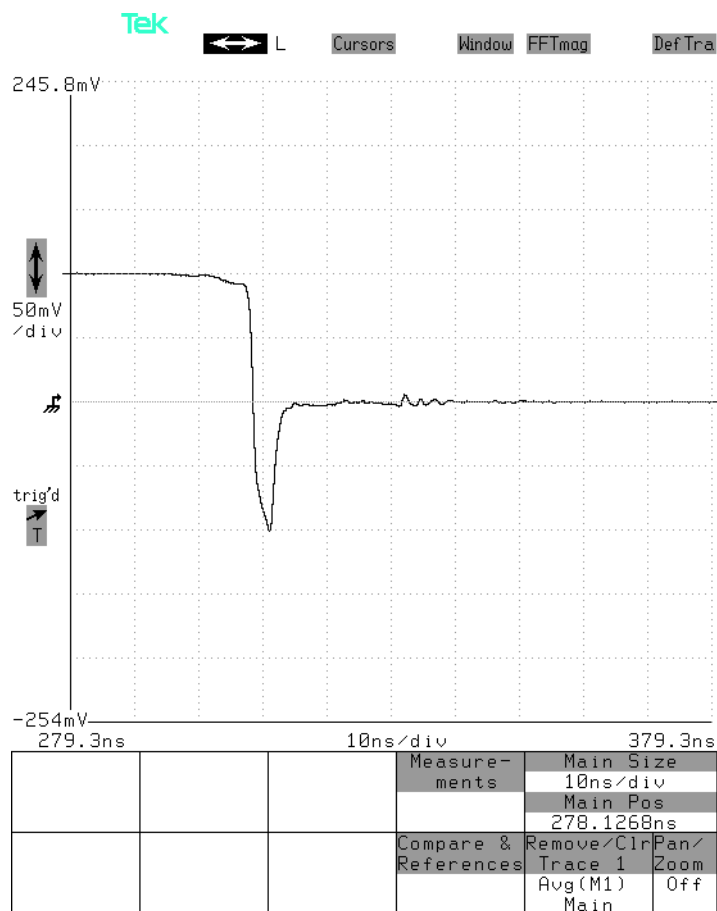

5 V/div (= 100 mA/div), 20 ns/div.
AVX-TRR-SOCK, S/N 11999.

The AVX-TRR-SOCK shows no significant ringing. The duration of the reverse recovery transient is similar to that obtained from the AVX-TRR-DIPFP jig (ignoring the trailing ringing).

The lower inductance of the AVX-TRR-SOCK jig means that a somewhat lower negative voltage is needed to generate the desired current (i.e, less inductive voltage must be overcome).

10 mA DIP RESULTS (1N6511)

The Microsemi 1N6511 DIP-packaged device was tested with amplitudes set to +0.85V and -2.7V. Pin socket 16 was used as the anode (since this is a 14-pin device, this pin socket corresponds to pin 14 of the device), and pin socket 1 was used as the cathode. The following reverse recovery waveform was obtained at the test jig "OUT" terminal of the AVR-TRR-DIPFP jig:

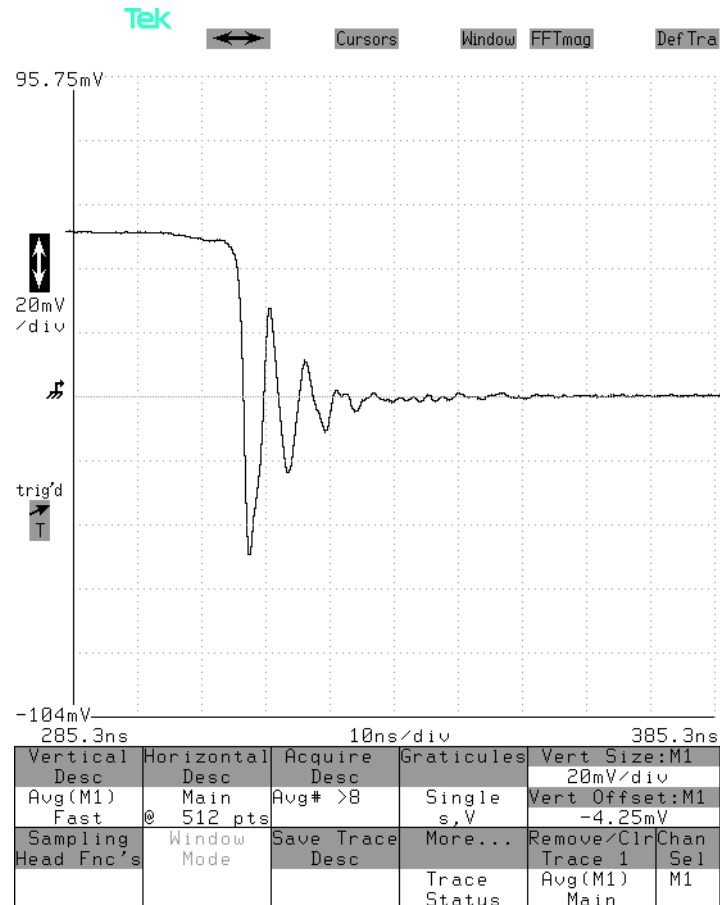

200 mV/div (= 4 mA/div), 10 ns/div.
AVX-TRR-DIPFP, S/N 11999.

The above waveform shows the transition from a forward current of +10 mA to a reverse current of -10 mA. The reverse recovery transient is extremely fast and sharp. The parasitic inductance in the circuit causes some ringing after the transient.

The main reverse transient is approximately 4 ns in duration, far exceeding the 10 ns figure specified in MIL-PRF-19500/474F for this device.

The ringing is undesirable, but unavoidable with the AVX-TRR-DIPFP. However, we can use the AVX-TRR-SOCK to confirm that the results are still valid. Using the AVX-TRR-

SOCK to test the same two pins, with amplitudes of +0.85V and -1.03V, generates this waveform:

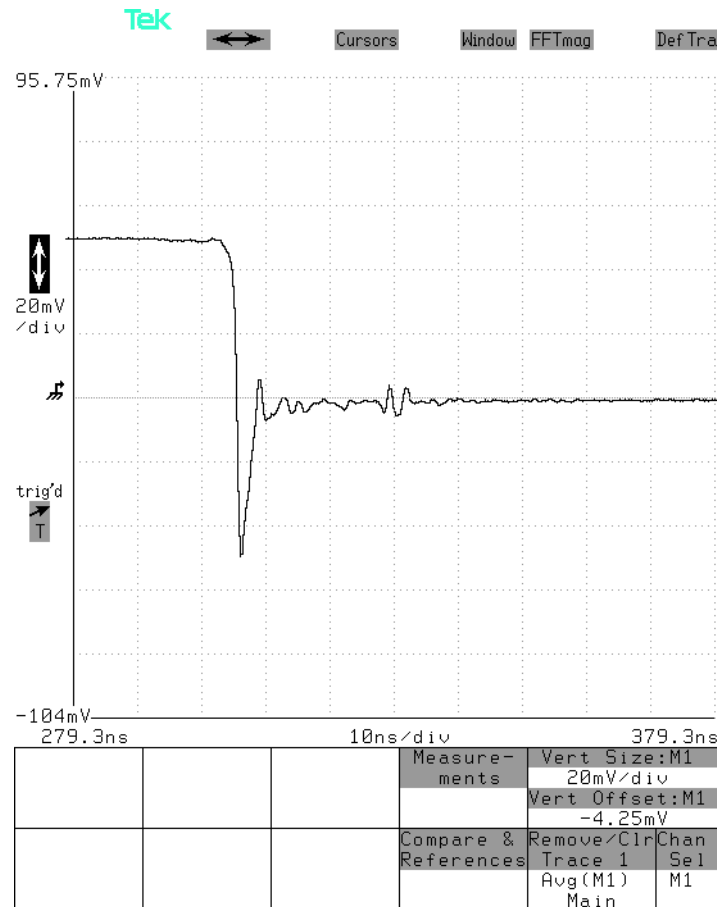

200 mV/div (= 4 mA/div), 10 ns/div.
AVX-TRR-SOCK, S/N 11999.

The AVX-TRR-SOCK shows minimal ringing. The duration of the reverse recovery transient is similar to that obtained from the AVX-TRR-DIPFP jig (ignoring the trailing ringing).

The lower inductance of the AVX-TRR-SOCK jig means that a somewhat lower negative voltage is needed to generate the desired current (i.e, less inductive voltage must be overcome).

10 mA FLAT-PACK RESULTS (1N6100)

The Microsemi 1N6100 14-pin flat-pack device was tested with amplitudes set to +0.85V and -3.5V. Pin socket 16 was used as the anode (since this is a 14-pin device, this pin socket corresponds to pin 14 of the device), and pin socket 1 was used as the cathode. The following reverse recovery waveform was obtained at the test jig "OUT" terminal of the AVR-TRR-DIPFP jig:

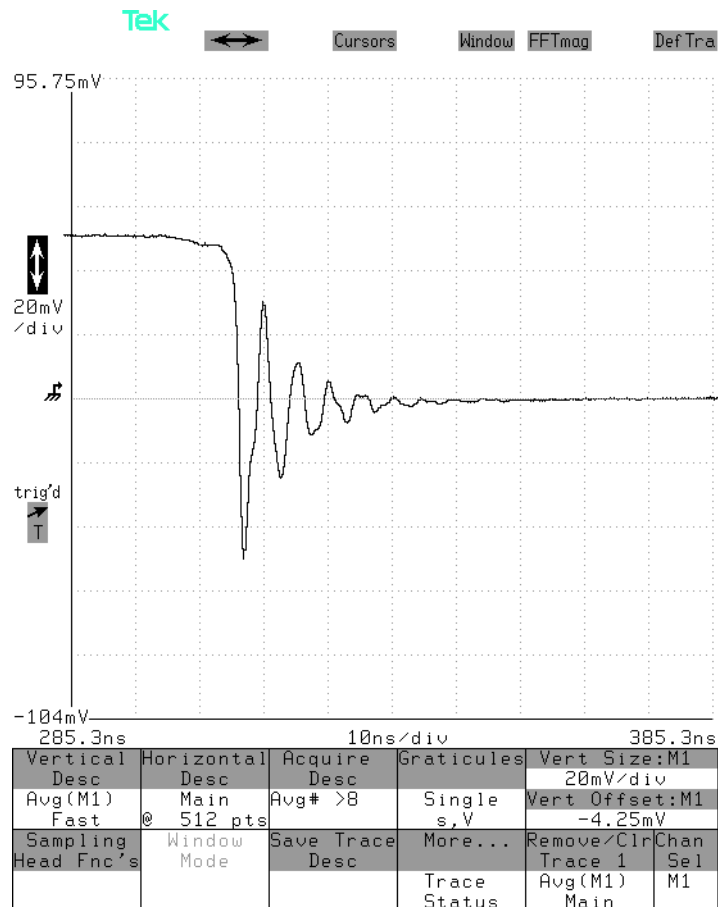

200 mV/div (= 4 mA/div), 10 ns/div.
AVX-TRR-DIPFP, S/N 11999.

The above waveform shows the transition from a forward current of +10 mA to a reverse current of -10 mA. The reverse recovery transient is extremely fast and sharp. The parasitic inductance in the circuit causes some ringing after the transient.

The main reverse transient is approximately 5 ns in duration, far exceeding the 10 ns figure specified in MIL-PRF-19500/474F for this device.

The ringing is undesirable, but unavoidable with the AVX-TRR-DIPFP. However, we can use the AVX-TRR-SOCK to confirm that the results are still valid. Using the AVX-TRR-

SOCK to test the same two pins, with amplitudes of +0.85V and -1.15V, generates this waveform:

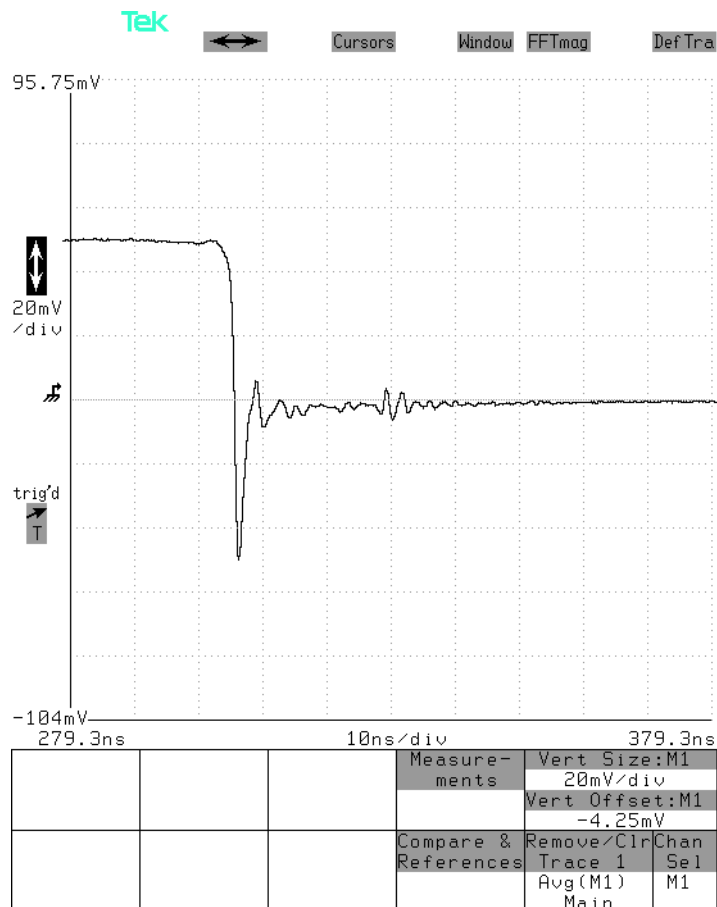

200 mV/div (= 4 mA/div), 10 ns/div.
AVX-TRR-SOCK, S/N 11999.

The AVX-TRR-SOCK shows minimal ringing. The duration of the reverse recovery transient is similar to that obtained from the AVX-TRR-DIPFP jig (ignoring the trailing ringing).

The lower inductance of the AVX-TRR-SOCK jig means that a somewhat lower negative voltage is needed to generate the desired current (i.e, less inductive voltage must be overcome).

PROGRAMMING YOUR PULSE GENERATOR

KEY PROGRAMMING COMMANDS

The “Programming Manual for -B Instruments” describes in detail how to connect the pulse generator to your computer, and the programming commands themselves. A large number of commands are available; however, normally you will only need a few of these. Here is a basic sample sequence of commands that might be sent to the instrument after power-up:

*rst	(resets the instrument)
trigger:source internal	(selects internal triggering)
frequency 1000 Hz	(sets the frequency to 1000 Hz)
pulse:delay 1 us	(sets the delay to 1 us)
volt:ampl1 +10	(sets the positive pulse amplitude to +10 V)
volt:ampl2 -20	(sets the negative pulse amplitude to -20 V)
route:close (@anod(4))	(applies the anode signal to pin socket 4)
route:close (@cath(8))	(applies the cathode signal to pin socket 8)
output on	(turns on the output)

For triggering a single event, this sequence would be more appropriate:

*rst	(resets the instrument)
trigger:source hold	(turns off all triggering)
output on	(turns on the output)
pulse:delay 1 us	(sets the delay to 1 us)
volt:ampl1 +10	(sets the positive pulse amplitude to +10 V)
volt:ampl2 -20	(sets the negative pulse amplitude to -20 V)
route:close (@anod(4))	(applies the anode signal to pin socket 4)
route:close (@cath(8))	(applies the cathode signal to pin socket 8)
trigger:source immediate	(generates a single non-repetitive trigger event)
trigger:source hold	(turns off all triggering)
output off	(turns off the output)

To set the instrument to trigger from an external TTL signal applied to the rear-panel TRIG connector, use:

*rst	(resets the instrument)
trigger:source external	(selects external triggering)
pulse:delay 1 us	(sets the delay to 1 us)
volt:ampl1 +10	(sets the positive pulse amplitude to +10 V)
volt:ampl2 -20	(sets the negative pulse amplitude to -20 V)
route:close (@anod(4))	(applies the anode signal to pin socket 4)
route:close (@cath(8))	(applies the cathode signal to pin socket 8)
output on	(turns on the output)

These commands will satisfy 90% of your programming needs.

ALL PROGRAMMING COMMANDS

For more advanced programmers, a complete list of the available commands is given below. These commands are described in detail in the “Programming Manual for -B Instruments”. (Note: this manual also includes some commands that are not implemented in this instrument. They can be ignored.)

<u>Keyword</u>	<u>Parameter</u>	<u>Notes</u>
LOCAL		
OUTPut:		
:[STATe]	<boolean value>	
:PROTection		
:TRIPped?		[query only]
REMOTE		
ROUte:		
:CLOSe	<channel list>	
[SOURce]:		
:FREQUency		
[:CW FIXed]	<numeric value>	
[SOURce]:		
:PULSe		
:PERiod	<numeric value>	
:WIDTh	<numeric value>	
:DELay	<numeric value>	
:GATE		
:LEVel	High Low	
[SOURce]:		
:VOLTage		
[:LEVel]		
[:IMMediate]		
[:AMPLitude]	<numeric value>	
:PROTection		
:TRIPped?		[query only]
STATUS:		
:OPERation		
:[EVENT]?		[query only, always returns "0"]
:CONDition?		[query only, always returns "0"]
:ENABle	<numeric value>	[implemented but not useful]
:QUEStionable		
:[EVENT]?		[query only, always returns "0"]
:CONDition?		[query only, always returns "0"]
:ENABle	<numeric value>	[implemented but not useful]
SYSTEM:		
:COMMunicate		
:GPIB		
:ADDReSS	<numeric value>	
:SERial		
:CONTRol		
:RTS	ON IBFull RFR	

:[RECeive]		
:BAUD	1200 2400 4800 9600	
:BITS	7 8	
:ECHO	<boolean value>	
:PARity		
:[TYPE]	EVEN ODD NONE	
:SBITS	1 2	
:ERRor		
:[NEXT]?		[query only]
:COUNT?		[query only]
:VERSion?		[query only]
TRIGger:		
:SOURce	INTernal EXTernal MANual HOLD IMMEDIATE	
*CLS		[no query form]
*ESE	<numeric value>	
*ESR?		[query only]
*IDN?		[query only]
*OPC		
*SAV	0 1 2 3	[no query form]
*RCL	0 1 2 3	[no query form]
*RST		[no query form]
*SRE	<numeric value>	
*STB?		[query only]
*TST?		[query only]
*WAI		[no query form]

MECHANICAL INFORMATION

TOP COVER REMOVAL

If necessary, the interior of the instrument may be accessed by removing the four Phillips screws on the top panel. With the four screws removed, the top cover may be slid back (and off).

 Always disconnect the power cord and allow the instrument to sit unpowered for 10 minutes before opening the instrument. This will allow any internal stored charge to discharge.

There are no user-adjustable internal circuits. For repairs other than fuse replacement, please contact Avtech (info@avtechpulse.com) to arrange for the instrument to be returned to the factory for repair. Service is to be performed solely by qualified service personnel.

 Caution: High voltages are present inside the instrument during normal operation. Do not operate the instrument with the cover removed.

RACK MOUNTING

A rack mounting kit is available. The -R5 rack mount kit may be installed after first removing the one Phillips screw on the side panel adjacent to the front handle.

ELECTROMAGNETIC INTERFERENCE

To prevent electromagnetic interference with other equipment, all used outputs should be connected to shielded loads using shielded coaxial cables. Unused outputs should be terminated with shielded coaxial terminators or with shielded coaxial dust caps, to prevent unintentional electromagnetic radiation. All cords and cables should be less than 3m in length.

MAINTENANCE

REGULAR MAINTENANCE

This instrument does not require any regular maintenance.

On occasion, one or more of the four rear-panel fuses may require replacement. All fuses can be accessed from the rear panel. See the “FUSES” section for details.

CLEANING

If desired, the interior of the instrument may be cleaned using compressed air to dislodge any accumulated dust. (See the “TOP COVER REMOVAL” section for instructions on accessing the interior.) No other cleaning is recommended.

WIRING DIAGRAMS

WIRING OF AC POWER

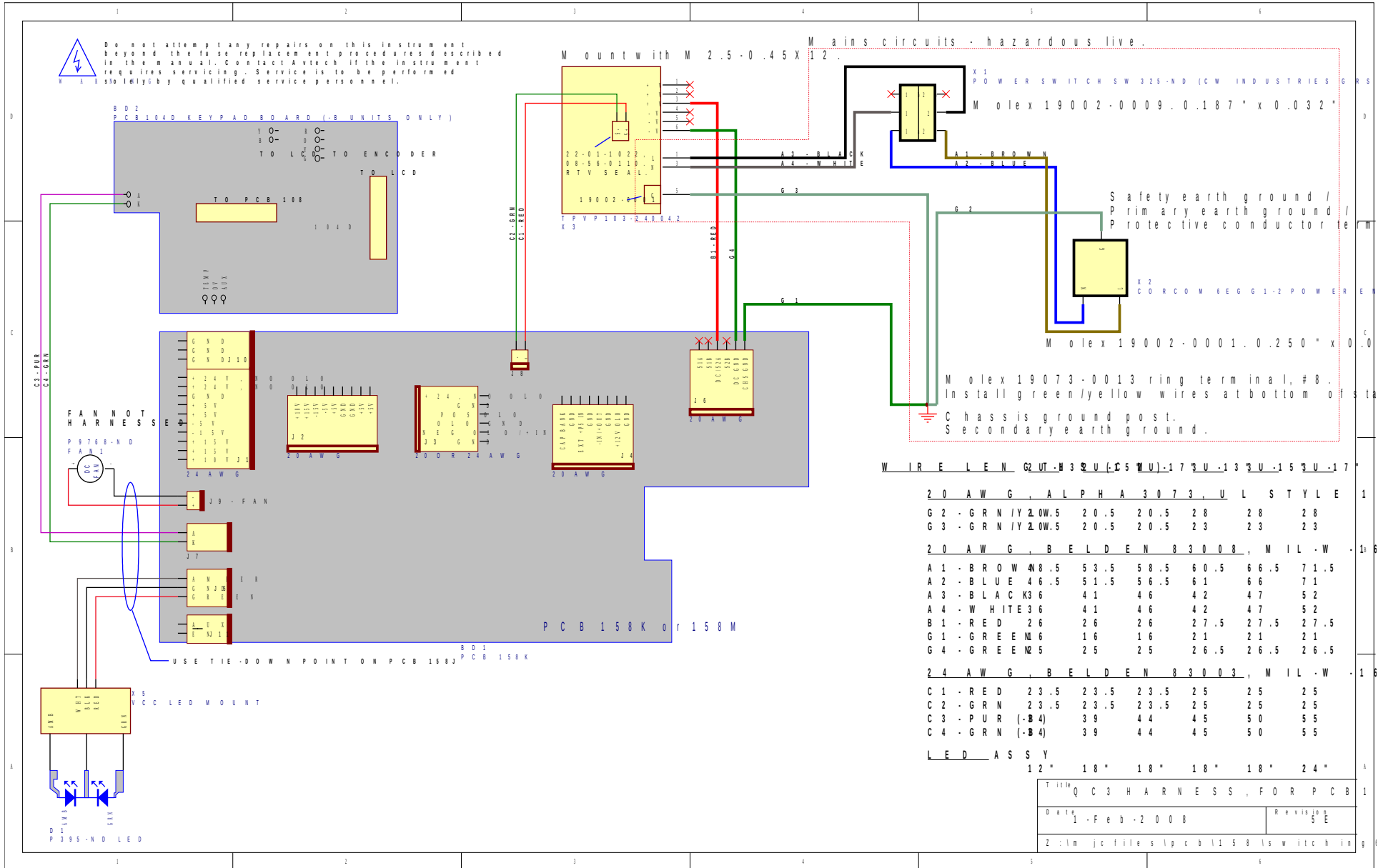

PCB 158M - LOW VOLTAGE POWER SUPPLY, 1/3

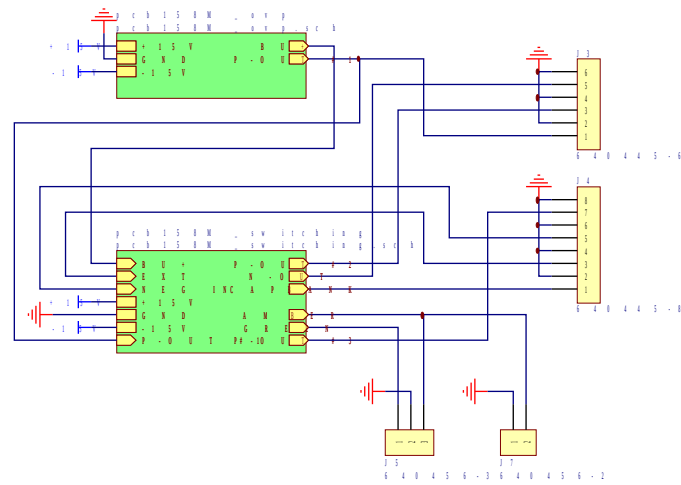

T I T L E	
L O W V O L T A G E D C / D C P O W	
D A T E	
1 - F e b - 2 0 0 8	
R e v i s i o n	
Z : \\m j c f i l e s \p c b \1 5 8 \s w i t c h i n g	

PCB 158M - LOW VOLTAGE POWER SUPPLY, 2/3

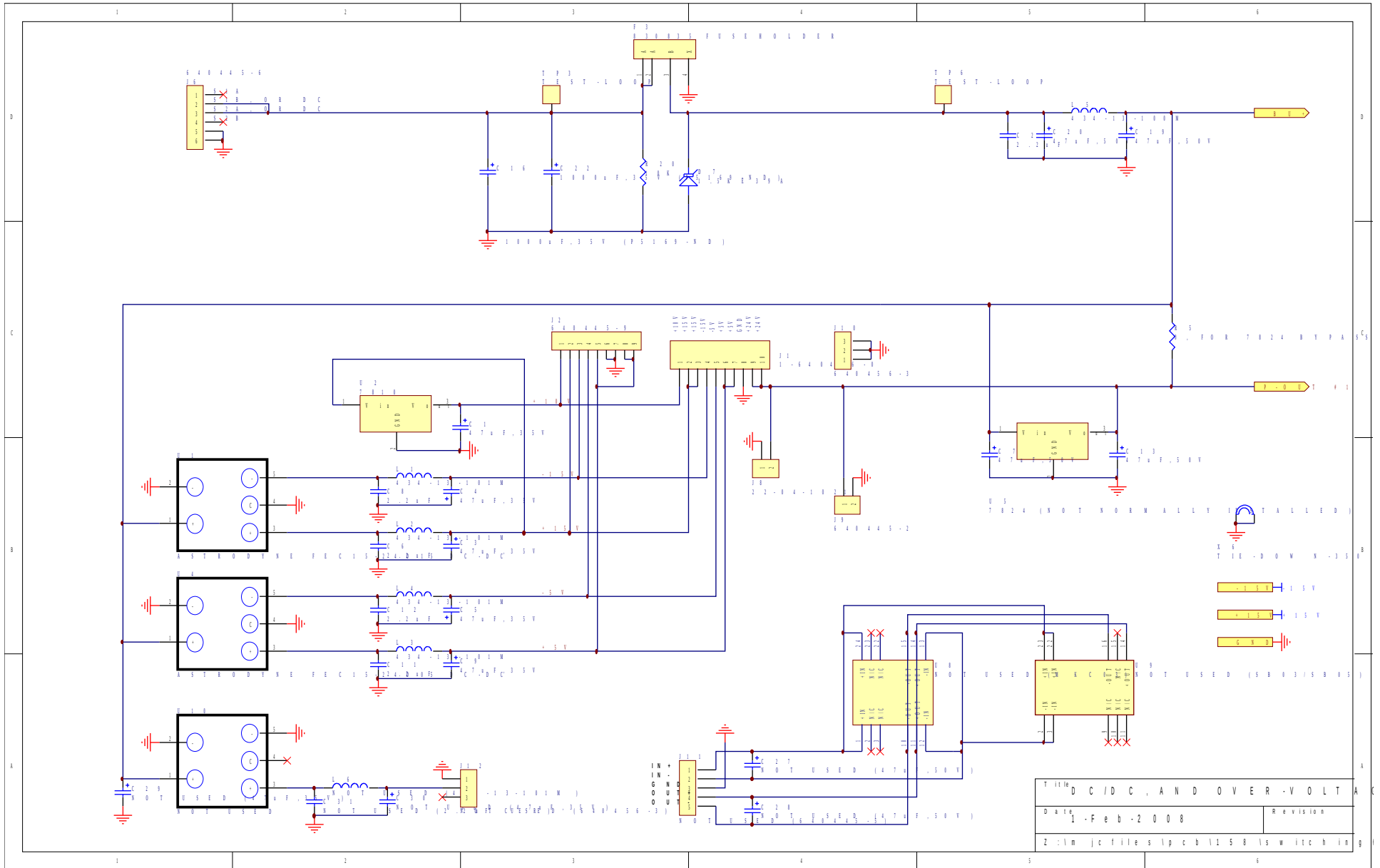

PCB 158M - LOW VOLTAGE POWER SUPPLY, 3/3

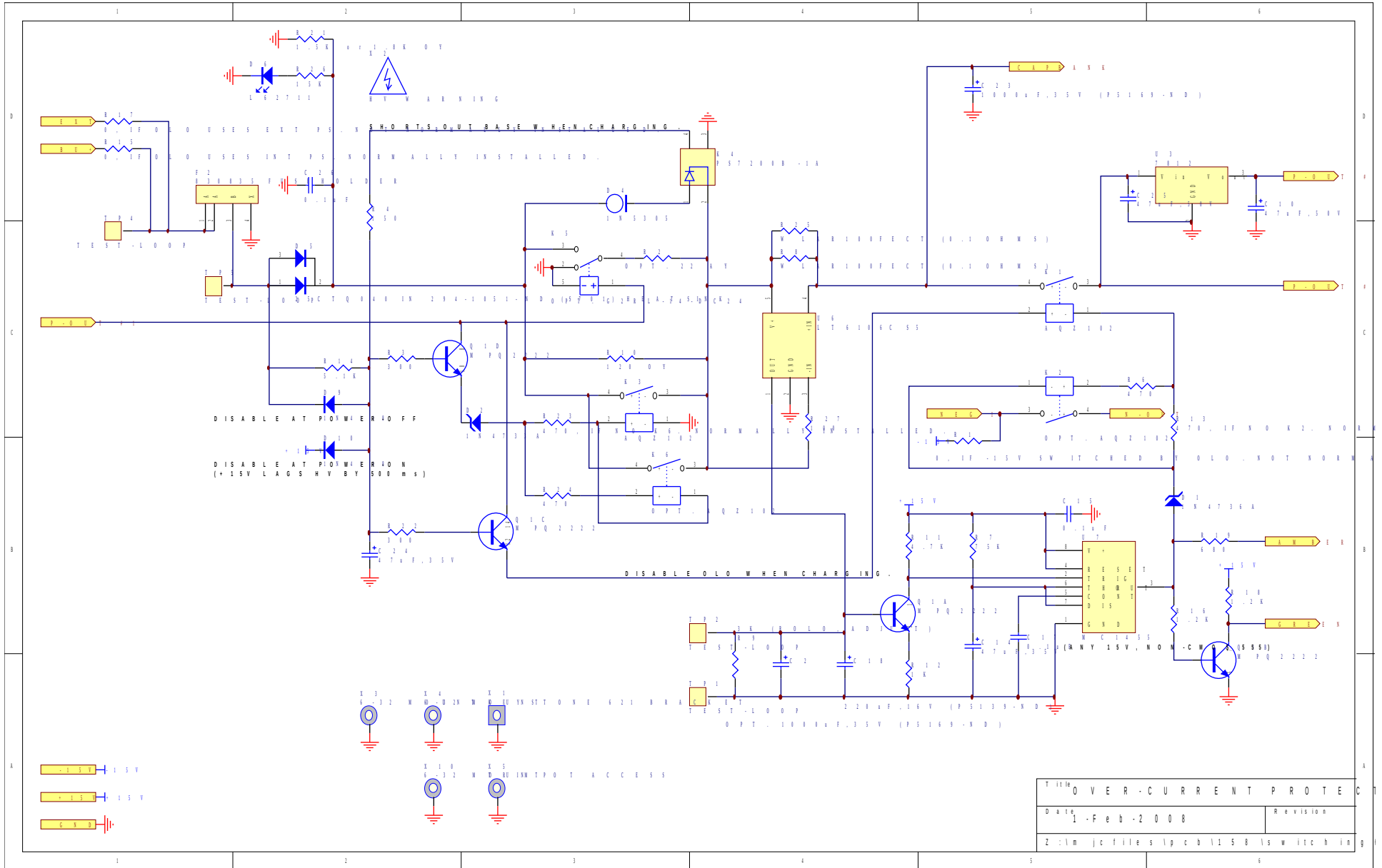

PCB 168B - HIGH VOLTAGE DC POWER SUPPLY

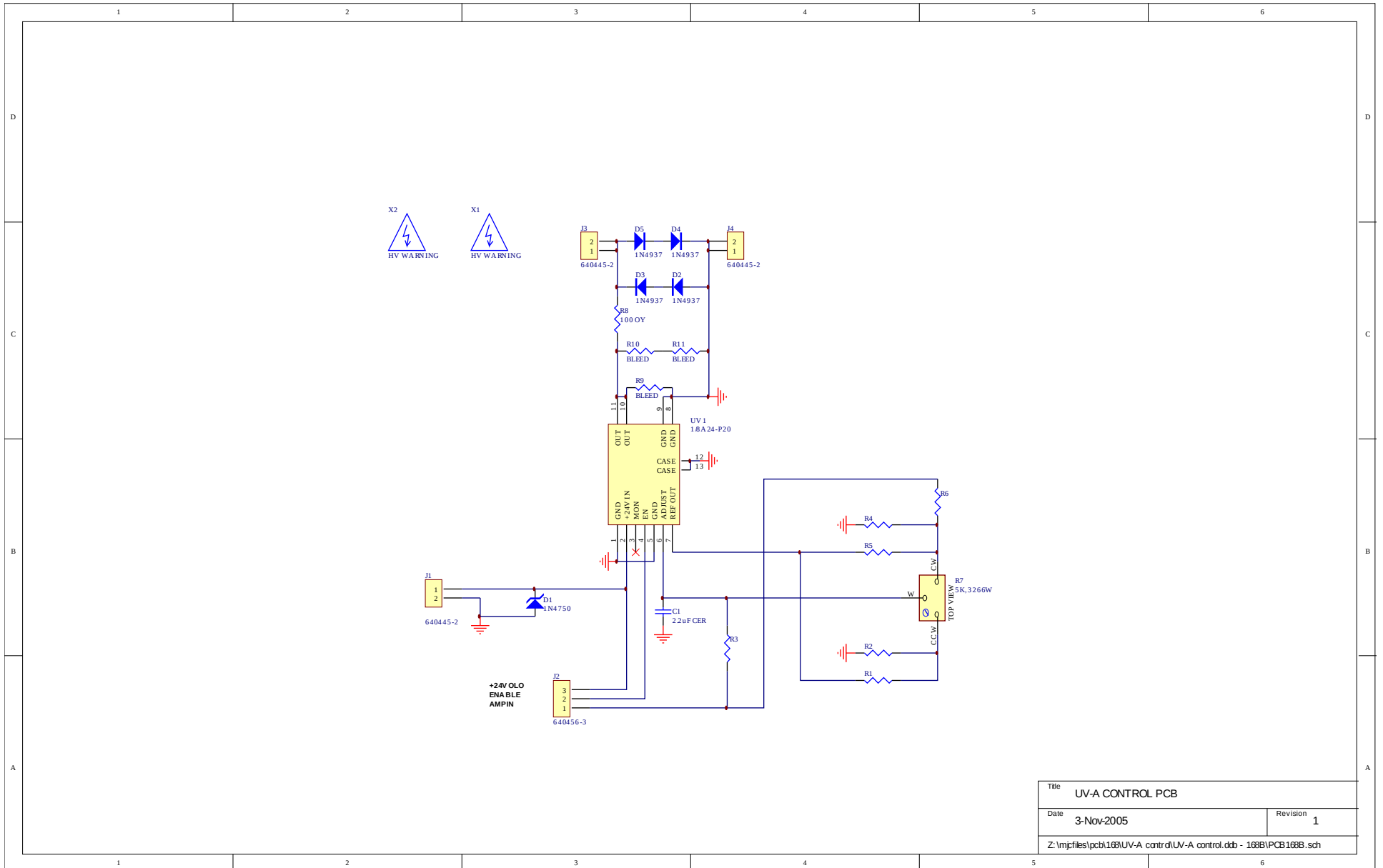

Title UV-A CONTROL PCB	
Date 3-Nov-2005	Revision 1
Z:\m\jfiles\pcb\168\UV-A control\UV-A control.ddb - 168B\PCB168B.sch	

PCB 104D - KEYPAD / DISPLAY BOARD, 1/3

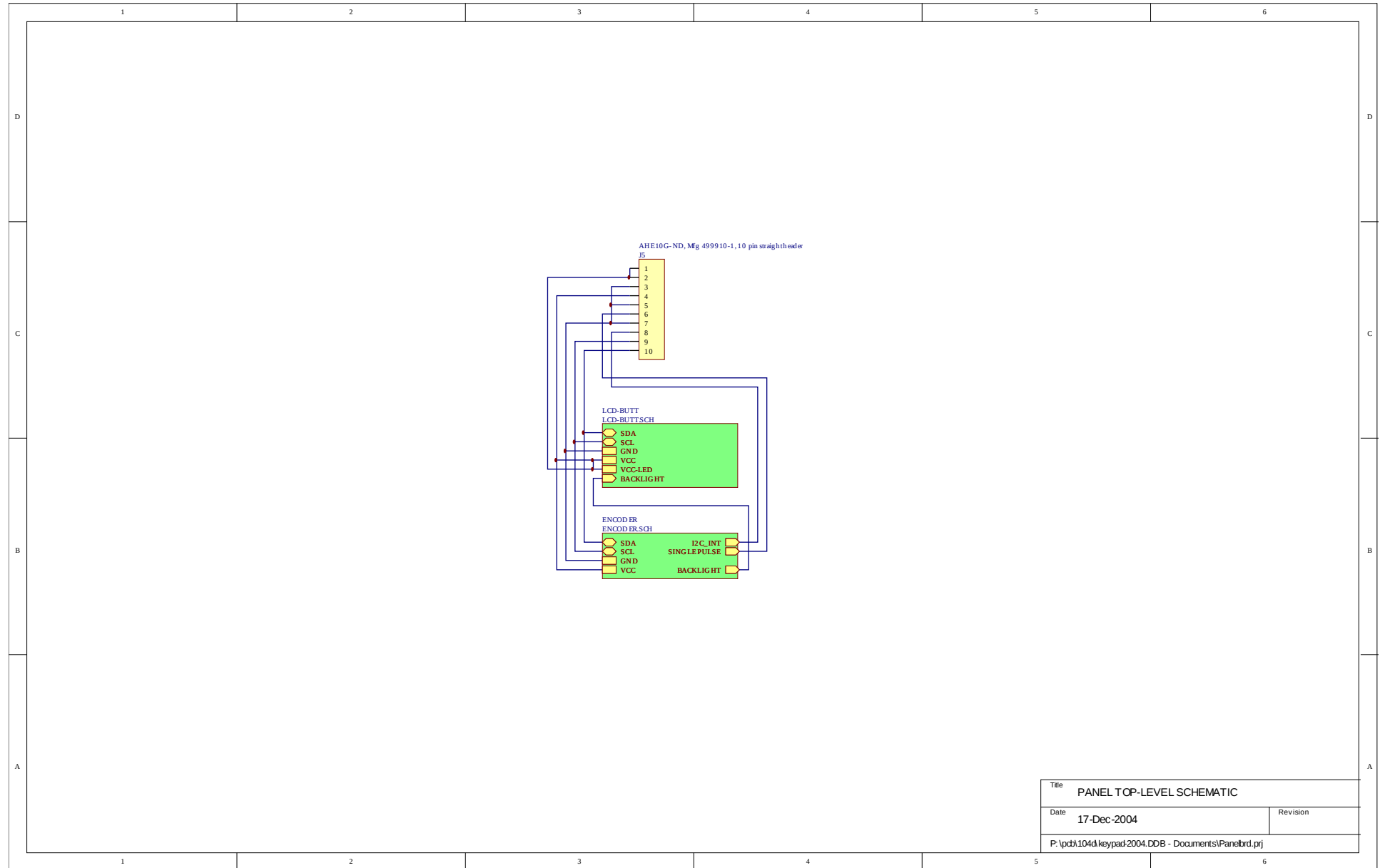

PCB 104D - KEYPAD / DISPLAY BOARD, 2/3

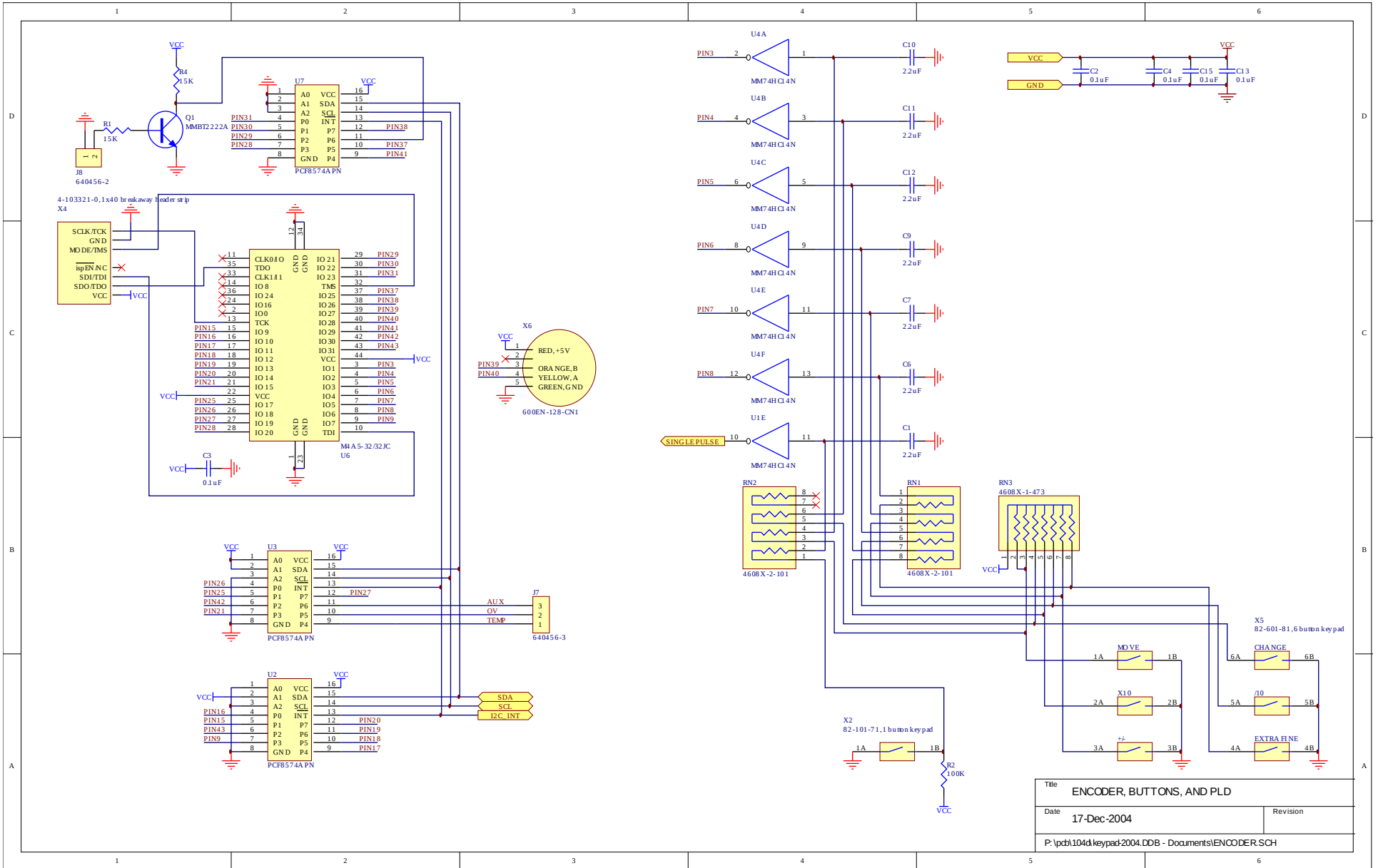

PCB 104D - KEYPAD / DISPLAY BOARD, 3/3

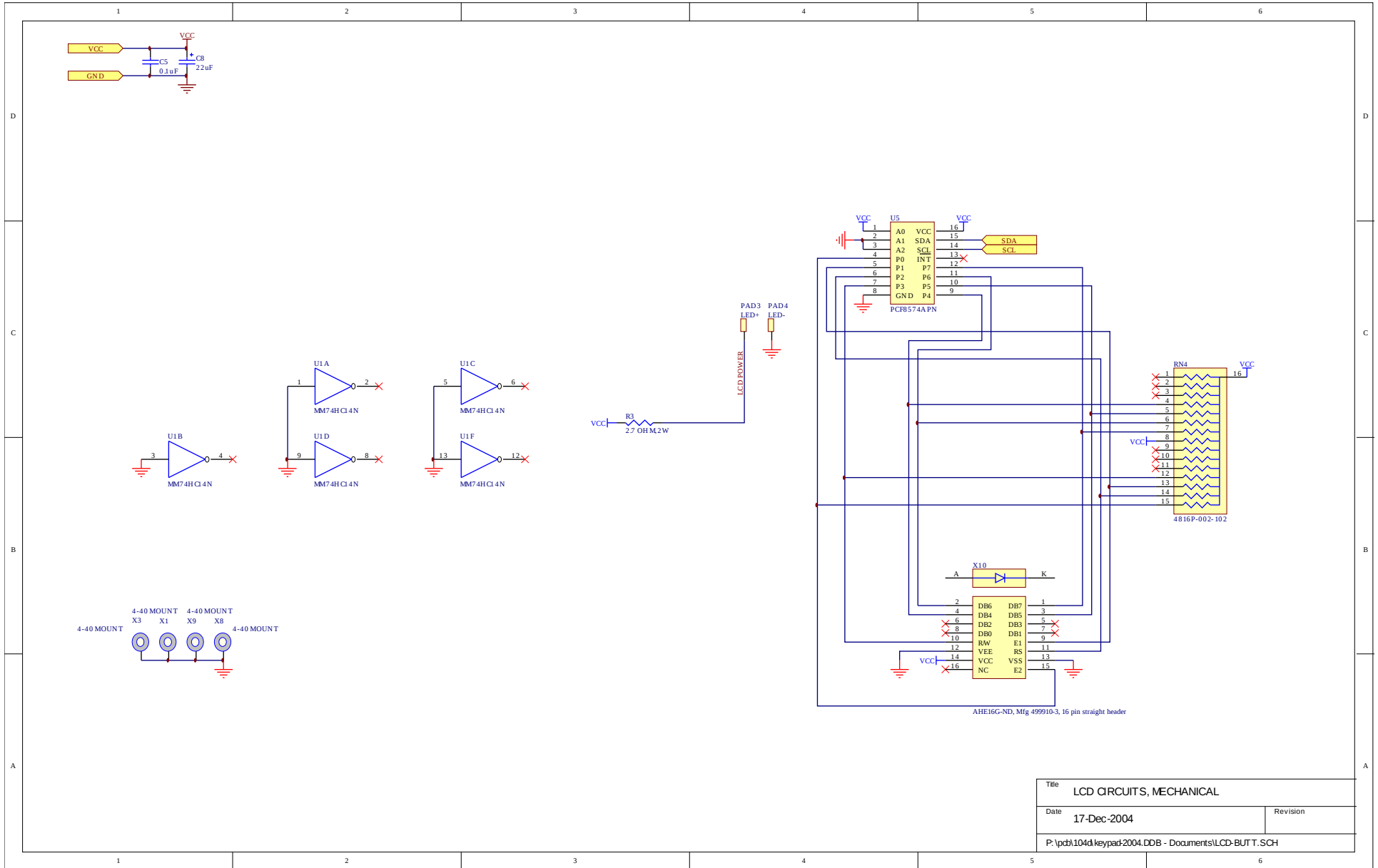

PCB 201B - INTERLOCK CONTROL

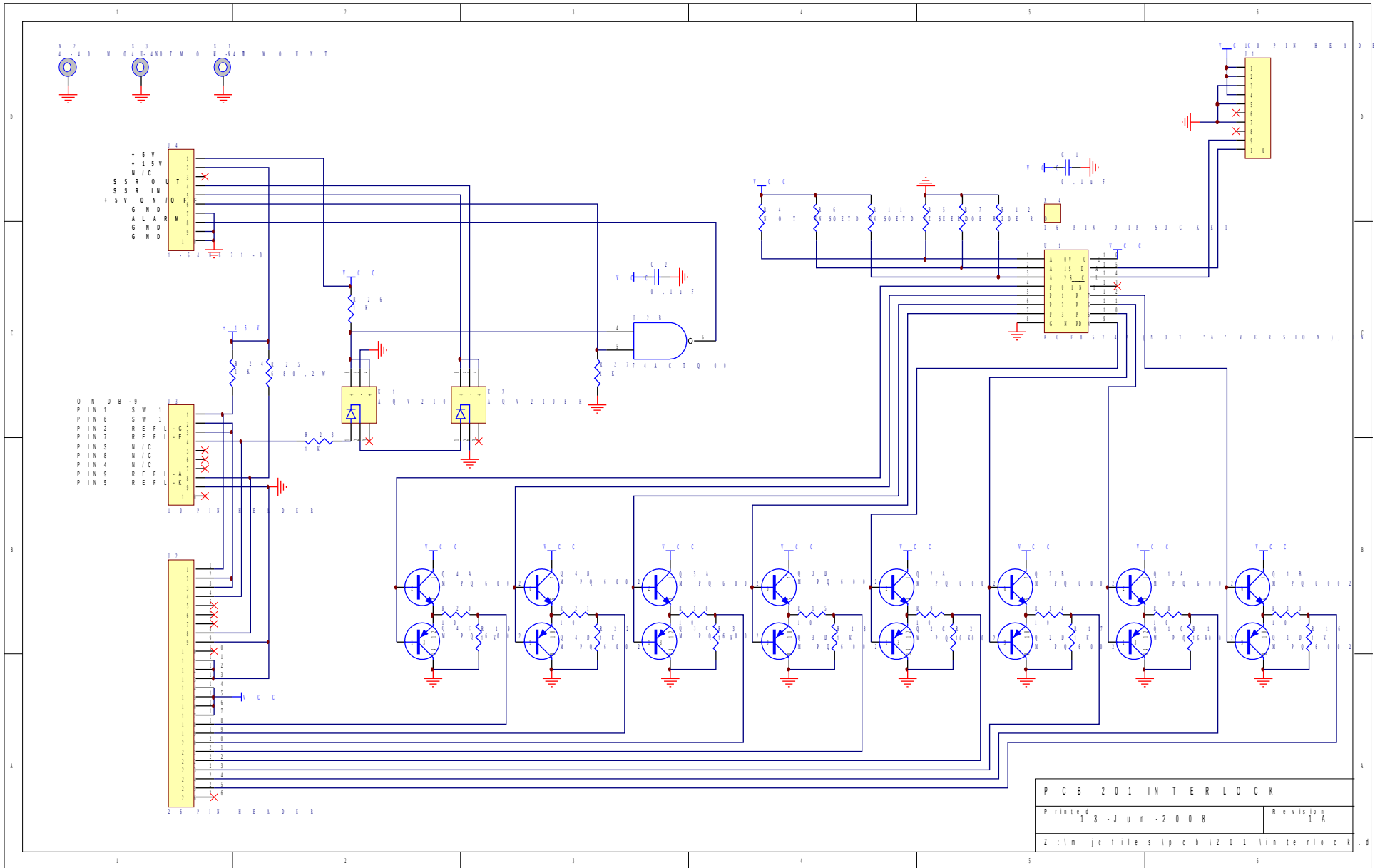

PCB 201 INTERLOCK	
Printed 13-Jun-2008	Revision 1A
Z:\lm\jc\files\lpcb\201\interlock.k	

PCB 204-1A – NEGATIVE TIMING CONTROL PCB

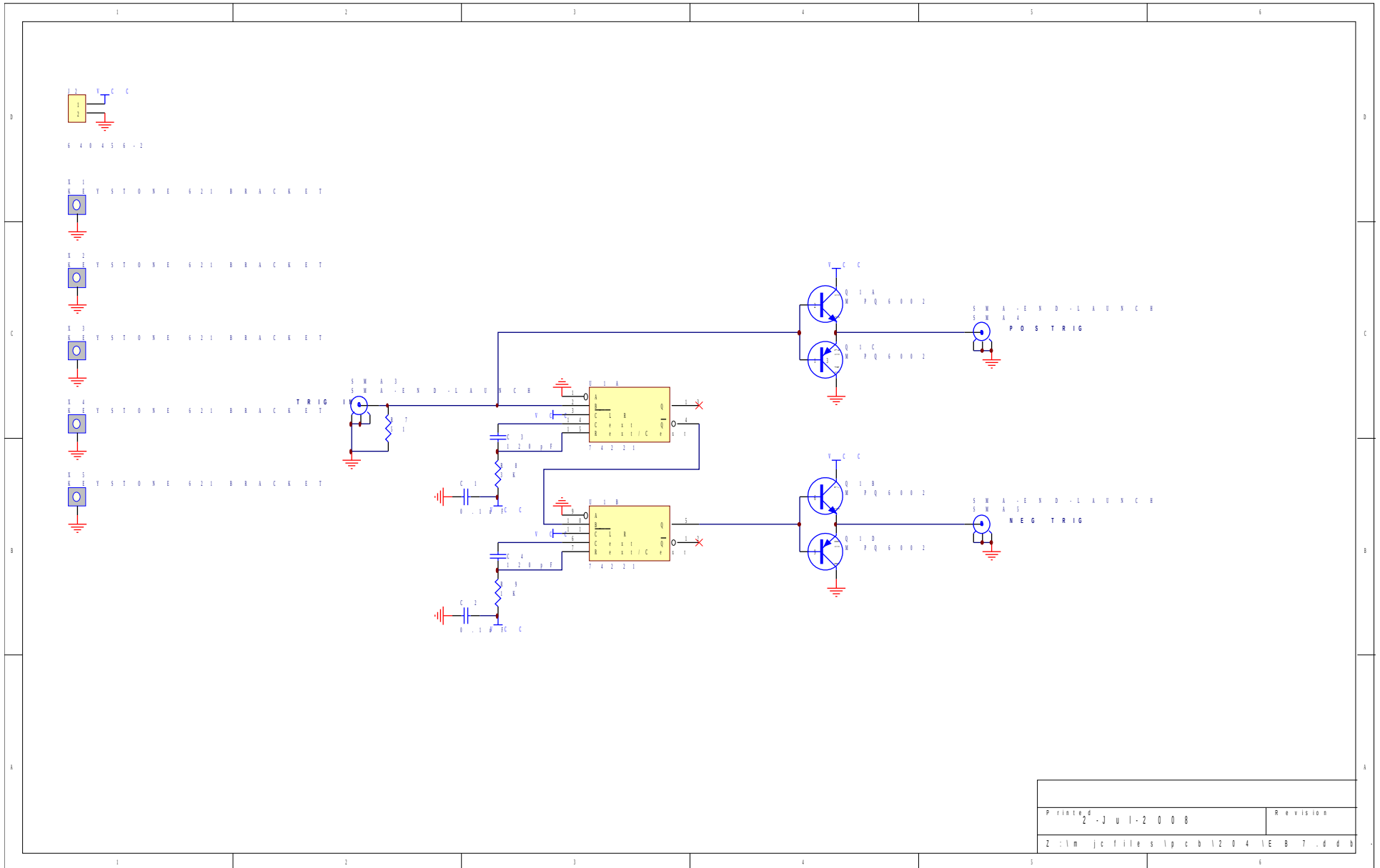

Printed	Revision
2-JUL-2008	
Z:\lm\jc\files\pcb\204\EB7.d4b	

MAIN WIRING

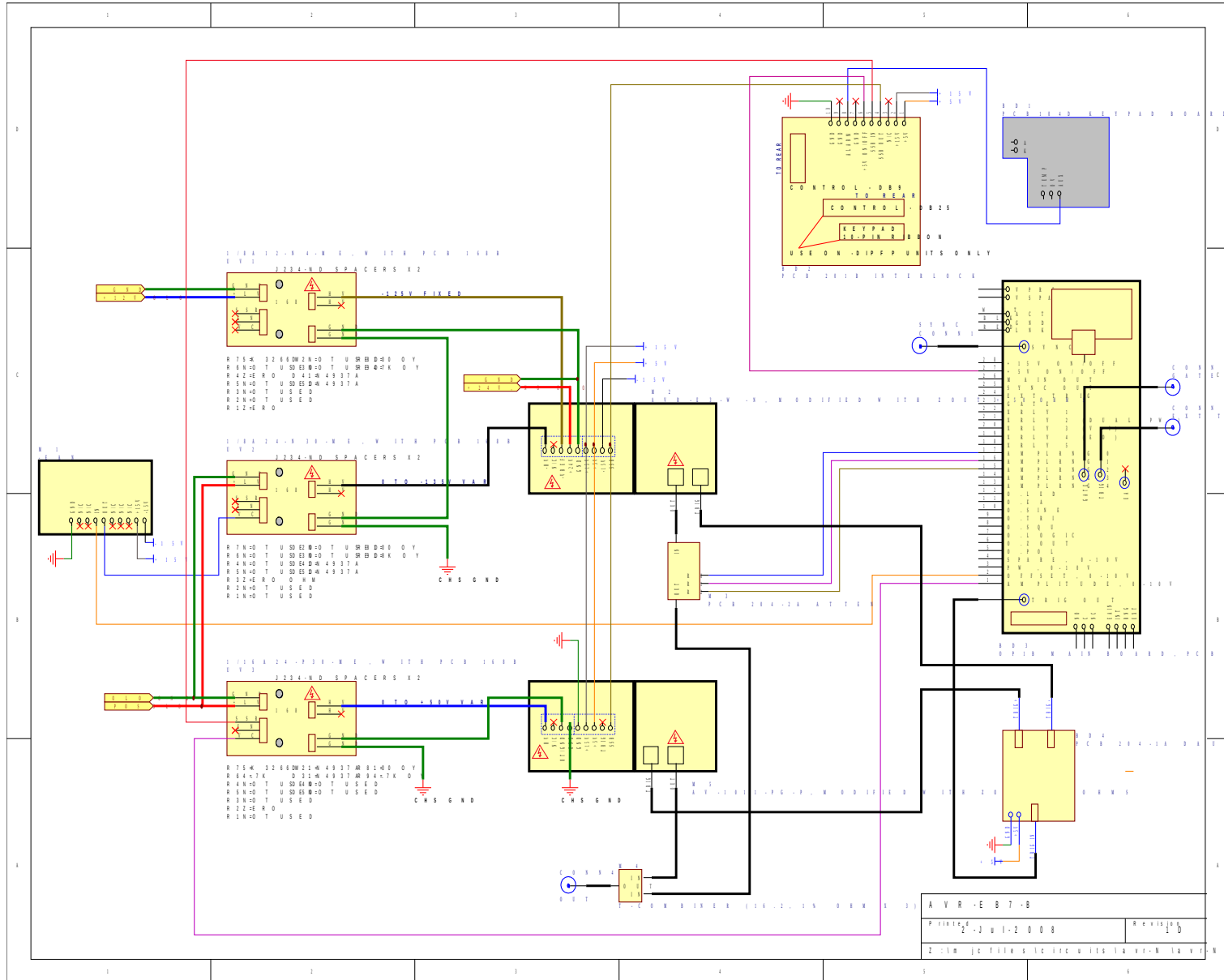

TEST JIG WIRING (AVX-TRR-DIPFP)

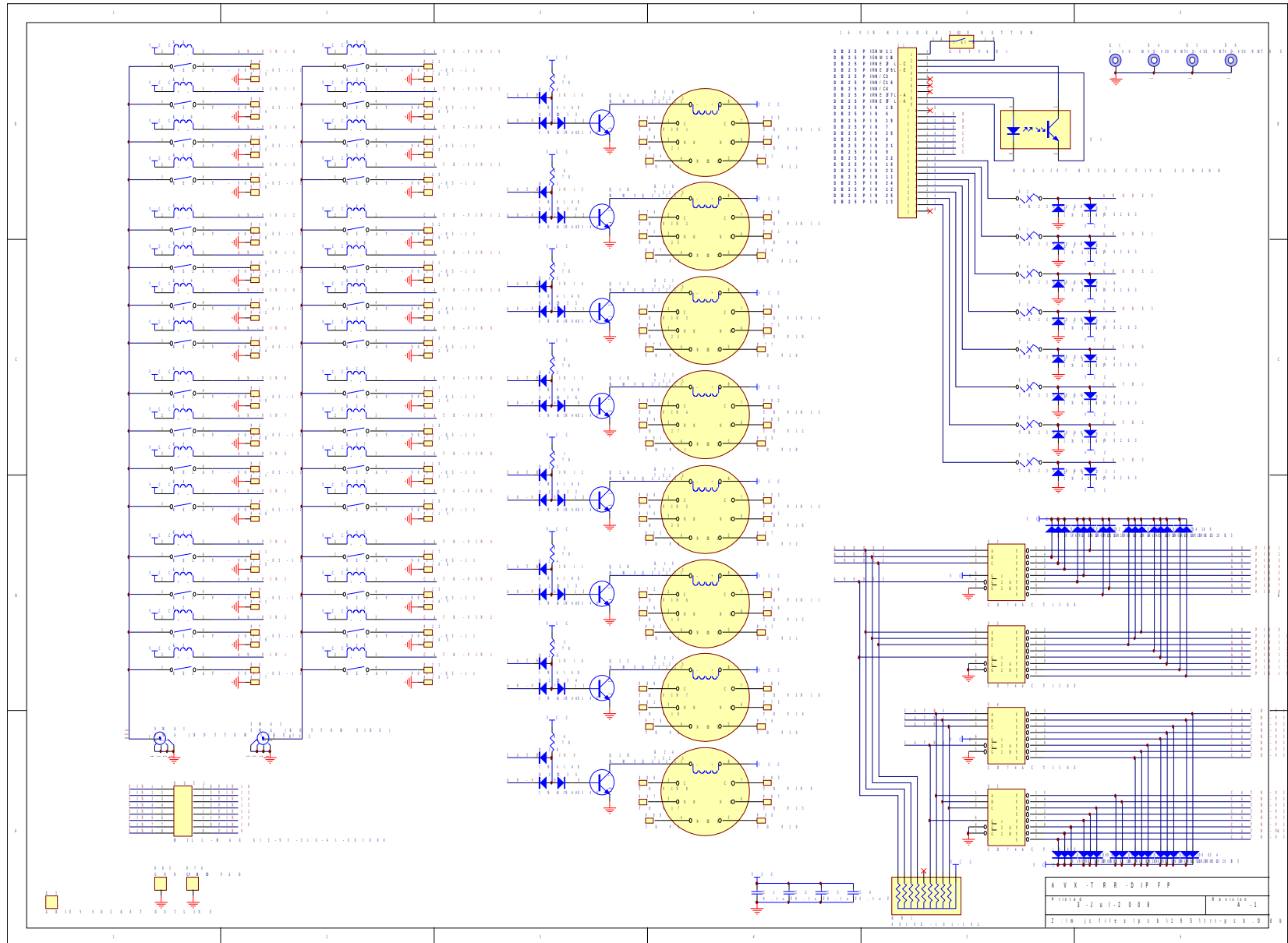

PERFORMANCE CHECK SHEET