



AVTECH ELECTROSYSTEMS LTD.

NANOSECOND WAVEFORM ELECTRONICS  
SINCE 1975

info@avtechpulse.com  
http://www.avtechpulse.com/

Tel: 888-670-8729 (USA & Canada)  
or +1-613-686-6675 (Worldwide)

BOX 5120, LCD MERIVALE  
OTTAWA, CANADA K2C3H5

## INSTRUCTIONS

MODEL AVR-EBF6-B

UP TO +1 Amp

FORWARD RECOVERY

$t_{FR}$  /  $V_{FR}$  MEASUREMENT SYSTEM

WITH IEEE 488.2 / RS-232 / ETHERNET CONTROL

SERIAL NUMBER: 14260

### WARRANTY

Avtech Electrosystems Ltd. warrants products of its manufacture to be free from defects in material and workmanship under conditions of normal use. If, within one year after delivery to the original owner, and after prepaid return by the original owner, this Avtech product is found to be defective, Avtech shall at its option repair or replace said defective item. This warranty does not apply to units which have been disassembled, modified or subjected to conditions exceeding the applicable specifications or ratings. This warranty is the extent of the obligation assumed by Avtech with respect to this product and no other warranty or guarantee is either expressed or implied.

### TECHNICAL SUPPORT

Phone: 888-670-8729 (USA & Canada)  
or +1-613-686-6675 (Worldwide)

E-mail: [info@avtechpulse.com](mailto:info@avtechpulse.com)  
World Wide Web: <http://www.avtechpulse.com>

TABLE OF CONTENTS

|   |           |
|---|-----------|
| <b>WARRANTY.....</b>                            | <b>2</b>  |
| <b>TECHNICAL SUPPORT.....</b>                   | <b>2</b>  |
| <b>TABLE OF CONTENTS.....</b>                   | <b>3</b>  |
| <b>INTRODUCTION.....</b>                        | <b>6</b>  |
| <b>SPECIFICATIONS.....</b>                      | <b>8</b>  |
| <b>SPECIFICATIONS – INCLUDED TEST JIGS.....</b> | <b>9</b>  |
| <b>REGULATORY NOTES.....</b>                    | <b>10</b> |
| FCC PART 18.....                                | 10        |
| EC DECLARATION OF CONFORMITY.....               | 10        |
| DIRECTIVE 2011/65/EU (RoHS).....                | 11        |
| DIRECTIVE 2002/96/EC (WEEE).....                | 11        |
| FIRMWARE LICENSING.....                         | 12        |
| <b>INSTALLATION.....</b>                        | <b>13</b> |
| VISUAL CHECK.....                               | 13        |
| POWER RATINGS.....                              | 13        |
| CONNECTION TO THE POWER SUPPLY.....             | 13        |
| PROTECTION FROM ELECTRIC SHOCK.....             | 14        |
| ENVIRONMENTAL CONDITIONS.....                   | 15        |
| <b>FUSES.....</b>                               | <b>16</b> |
| AC FUSE REPLACEMENT.....                        | 16        |
| DC FUSE REPLACEMENT.....                        | 17        |
| FUSE RATINGS.....                               | 17        |
| <b>FRONT PANEL CONTROLS.....</b>                | <b>18</b> |
| <b>REAR PANEL CONTROLS.....</b>                 | <b>20</b> |
| <b>TIMING CONTROL.....</b>                      | <b>22</b> |
| BASIC TIMING CONTROL.....                       | 22        |
| TRIGGER MODES.....                              | 23        |
| GATING MODES.....                               | 23        |
| <b>BASIC AMPLITUDE CONTROL.....</b>             | <b>25</b> |
| SETTING THE AMPLITUDE LEVELS.....               | 26        |
| AMPLITUDE ACCURACY.....                         | 26        |
| INCORRECT ORIENTATION.....                      | 27        |
| CABLE LENGTHS.....                              | 27        |

|  |           |
|--|-----------|
| ACCESSIBLE VOLTAGES.....                     | 27        |
| <b>BASIC MEASUREMENT THEORY.....</b>         | <b>28</b> |
| <b>TEST JIG MECHANICAL ASPECTS.....</b>      | <b>30</b> |
| ALL TEST JIGS.....                           | 30        |
| AVX-TFR-MIX TEST JIG.....                    | 30        |
| SPECIALTY TEST JIGS.....                     | 33        |
| AVX-TFR-SOD123W.....                         | 33        |
| AVX-TFR-SOD128.....                          | 35        |
| <b>TYPICAL RESULTS.....</b>                  | <b>36</b> |
| 1N5811 RESULTS.....                          | 36        |
| MQ1N5811US RESULTS.....                      | 38        |
| <b>TROUBLESHOOTING.....</b>                  | <b>39</b> |
| <b>PROGRAMMING YOUR PULSE GENERATOR.....</b> | <b>40</b> |
| KEY PROGRAMMING COMMANDS.....                | 40        |
| ALL PROGRAMMING COMMANDS.....                | 41        |
| <b>MECHANICAL INFORMATION.....</b>           | <b>43</b> |
| TOP COVER REMOVAL.....                       | 43        |
| RACK MOUNTING.....                           | 43        |
| ELECTROMAGNETIC INTERFERENCE.....            | 43        |
| <b>MAINTENANCE.....</b>                      | <b>44</b> |
| REGULAR MAINTENANCE.....                     | 44        |
| CLEANING.....                                | 44        |
| TRIGGER DAMAGE.....                          | 44        |
| <b>WIRING DIAGRAMS.....</b>                  | <b>45</b> |
| WIRING OF AC POWER.....                      | 45        |
| PCB 158R4 - LOW VOLTAGE POWER SUPPLY.....    | 46        |
| PCB 235D - HIGH VOLTAGE DC POWER SUPPLY..... | 47        |
| PCB 104H - KEYPAD / DISPLAY BOARD.....       | 48        |
| PCB 201C - INTERLOCK CONTROL.....            | 49        |
| MAIN WIRING.....                             | 50        |
| TEST JIG WIRING (AVX-TFR-MIX).....           | 51        |
| TEST JIG WIRING (AVX-TFR-SOD123W).....       | 52        |
| TEST JIG WIRING (AVX-TFR-SOD128).....        | 53        |
| <b>PERFORMANCE CHECK SHEET.....</b>          | <b>54</b> |

Last modified July 28, 2022.  
Copyright © 2022 Avtech Electrosystems Ltd, All Rights Reserved.

## INTRODUCTION

The AVR-EBF6-B is a high performance, GPIB/RS232/Ethernet-equipped test system for measuring the  $t_{FR}$  and  $V_{FR}$  forward recovery characteristics of high speed rectifiers.

The AVR-EBF6-B consists of three main components:

1. The instrument mainframe, which generates voltage pulses in the range of +2.5V to +50V with rise times < 5 ns.
2. A rise time filter, which increases the rise time of the voltage pulse to 10 ns (or optionally 8 ns, 12 ns, or 20 ns),  $\pm 20\%$ .
3. A test jig, into which the device under test (DUT) is inserted.

Depending on the options and accessories ordered, the instrument may be supplied with more than one rise time filter and more than one test jig.

The mainframe connects to the rise time filter using a length of coaxial cable. The output of the filter connects to the test jig using another length of coaxial cable. A control cable connects the mainframe to the test jig, to control the safety interlocks. The two test jig outputs are fed into the 50 Ohm inputs of an oscilloscope by two lengths of coaxial cable.

The (user-supplied) oscilloscope is used to measure the  $V_{FR}$  and  $t_{FR}$  values based on the waveforms from the test jig outputs.

The waveforms generated by this instrument are suitable for MIL-STD-750E Method 4026.3 tests. In the terminology of this standard:

- $I_F = 50 \text{ mA}$  up to 1 A
- Rise Time = 10 ns (unless the optional 8, 12, or 20 ns filters are used)
- Pulse width  $t_1 = 200 \text{ ns}$  to 10  $\mu\text{s}$
- Generator Resistance  $R_S = 50 \text{ Ohms}$
- Pulse frequency = 1 Hz to 10 kHz
- Response detector input impedance  $Z = 500 \text{ Ohms}$

The test jig supplied with the instrument is carefully constructed such that the parasitic inductance is minimized. This prevents overestimation of  $V_{FR}$ , and provides increased  $t_{FR}$  accuracy.

Standard AVR-EBF6-B models include one AVX-TFR-MIX diode test jig. This standard test jig contains a variety of pin sockets and posts, which may be used to hold the diode device under test (DUT). The test jig has a hinged lid, which must be fully closed to protect the user from high voltages. The output will be automatically disabled if the lid is left open. The standard AVR-TFR-MIX test jig will accommodate TO-220AC (2 lead)

packages, DO-style packages with leads bent at 90°, and standard and reverse-polarity TO-3 packages.

Other test jigs, accommodating different packages, are also available.

While the provided test jig is intended to be flexible and easy to use, users can also develop their own test jigs easily.

The AVR-EBF6-B includes an internal trigger source, but it can also be triggered or gated by an external source. A front-panel pushbutton can also be used to trigger the instrument.

The AVR-EBF6-B features front panel keyboard and adjust knob control of the output pulse parameters along with a four line by 40-character backlit LCD display of the output amplitude, pulse repetition frequency, and delay. The instrument includes memory to store up to four complete instrument setups. The operator may use the front panel or the computer interface to store a complete “snapshot” of all key instrument settings, and recall this setup at a later time.

This instrument is intended for use in research, development, test and calibration laboratories by qualified personnel.

## SPECIFICATIONS

|  |   |
|--|---|
| Model <sup>1</sup> :   | AVR-EBF6-B  |
| Recovery type:   | Forward recovery  |
| Intended application:  | High-speed rectifiers   |
| Basic waveform:  | A positive pulse  |
| Pulse polarity:  | +   |
| Voltage output <sup>2,5</sup> :<br>(to $R_L = 50\Omega$ )                      | +2.5V to +50V   |
| Corresponding diode current <sup>2,5</sup> (approx., depends on $V_{DIODE}$ ): | +50 mA to +1A   |
| Pulse width (FWHM):  | 200 ns to 10 $\mu$ s <sup>7</sup>   |
| Maximum duty cycle:  | 0.2%  |
| Rise time:<br>(10%-90%)  | No filter < 5 ns.<br>Standard filter <sup>4</sup> : 10 ns<br>Optional filters <sup>4</sup> : 8 ns,<br>12 ns, 20 ns  |
| Output impedance during pulse (inside the mainframe):                          | 50 Ohms   |
| Maximum PRF:   | 10 kHz  |
| Variable delay (sync out to main out, unless noted):                           | 0 to $\pm$ 1s, variable   |
| Included test jig <sup>3</sup> :   | See the table on the next page  |
| Connectors:  | Mainframe pulse output, jig pulse input: SMA<br>TRIG, GATE, SYNC: BNC   |
| GPIO & RS-232:   | Standard on -B units. See <a href="http://www.avtechpulse.com/gpio">http://www.avtechpulse.com/gpio</a> for details.  |
| Ethernet port, for remote control using VXI-11.3, ssh, telnet, & web:          | Included. Recommended as a modern alternative to GPIO / RS-232.<br>See <a href="http://www.avtechpulse.com/options/vxi">http://www.avtechpulse.com/options/vxi</a> for details.                               |
| Settings resolution:   | The resolution of the timing parameters (pulse width, delay, period) varies, but is always better than 0.15% of ( $ set\ value  + 20\ ns$ ). The amplitude resolution is < 0.1% of the maximum amplitude.     |
| Settings accuracy:   | Typically $\pm$ 3% after 10 minute warmup, for timing parameter. For high-accuracy applications requiring traceable calibration, verify the output parameters with a calibrated oscilloscope <sup>5,8</sup> . |
| Trigger modes:   | Internal trigger, external trigger (TTL level pulse, > 10 ns, 1 k $\Omega$ input impedance), front-panel "Single Pulse" pushbutton, or single pulse trigger via computer command.                             |
| Sync output:   | > +3 Volts, > 50 ns, will drive 50 Ohm loads  |
| Gate input:  | Active high or low, switchable. Suppresses triggering when active.  |
| Power requirements:  | 100 - 240 Volts, 50 - 60 Hz   |
| Dimensions:  | H x W x D: 100 mm x 430 mm x 375 mm (3.9" x 17" x 14.8")  |
| Chassis material:  | cast aluminum frame and handles, blue vinyl on aluminum cover plates  |
| Temperature range:   | +5°C to +40°C   |

- 1) -B suffix indicates IEEE-488.2 GPIO and RS-232 control of amplitude, pulse width, PRF and delay (see <http://www.avtechpulse.com/gpio>).
- 2) For operation at amplitudes of less than 10% of full-scale, best results will be obtained by setting the amplitude near full-scale and using external attenuators on the output.
- 3) Customized jigs available upon request.
- 4) The 10 ns (10%-90%) rise time filter is included as a standard feature. To add an 8 ns filter, add the -F8NS option to the model number. To add a 12 ns filter, add the -F12NS option to the model number. To add a 20 ns filter, add the -F20NS option to the model number. The rise time filter rise time accuracy is  $\pm$ 20%.
- 5) The amplitude settings should not be relied upon for any degree of accuracy, because the dynamics of the device under test can affect the actual generated waveforms. Amplitude settings should always be verified by oscilloscope measurements.
- 6) Depends on the parasitic inductance of the DUT and its leads.
- 7) Maximum pulse width is reduced to 500 ns for units with the -DIPFP option.
- 8) These instruments are provided with a basic calibration checksheet, showing a selection of measured output parameters. These measurements are performed with equipment that is calibrated on a regular basis by a third-party ISO/IEC 17025:2005 accredited calibration laboratory. However, Avtech itself does not claim any accreditation. For applications requiring traceable performance, use a calibrated measurement system rather than relying on the accuracy of the pulse generator settings.



## SPECIFICATIONS – INCLUDED TEST JIGS

| Option                           | Included Jig   | Typical Parasitic Inductance <sup>1</sup> , Maximum Current, Description |   |
|----------------------------------|----------------|--|---|
| <i>Preferred Jigs</i>            |                |  |   |
| -MIX<br>(or no option specified) | AVX-TFR-MIX    | 7 nH, 1A   | Standard on AVR-EBF6-B, AVR-EBF8-B. Includes a mix of pin sockets. Will accept TO-220AC (2 lead) packages, DO-style packages <sup>3</sup> (DO-15, DO-35, DO-41, DO-201AD, etc.) with leads bent at 90°, and standard and reverse-polarity TO-3 packages. Lead bending is required for axial packages. |
| -HPOST                           | AVX-TFR-HPOST  | 7 nH, 10A  | Standard on AVR-EBF10-B. High-current (up to 10A) jig for DO-41 packages (0.205" x 0.107" body, max) and Microsemi Axial Type E packages (0.185" x 0.135" body, max). Unlike the standard jig, bending is NOT required to insert these packages. This jig will not accept any other type of package.  |
| -SOD123                          | AVX-CA-SOD123  | 7 nH, 1A   | Accepts SOD123 packages. A clamp presses the DUT down against upwards-facing spring pins.   |
| -SOD123W                         | AVX-CA-SOD123W | 7 nH, 1A   | Accepts SOD123W packages. A clamp presses the DUT down against upwards-facing spring pins.  |
| -SOD128                          | AVX-CA-SOD128  | 7 nH, 1A   | Accepts SOD128 packages. A clamp presses the DUT down against upwards-facing spring pins.   |
| -SQMELF                          | AVX-TFR-SQMELF | 7 nH, 1A   | Square MELF jig. Accepts Microsemi Type A (D-5A) and Microsemi Type E (D-5B) "square MELF" packages. It also accepts Microsemi Type B (D-5D) and Microsemi Type G (D-5C) packages, although the fit is less optimal.  |
| -STUD                            | AVX-TFR-STUD   | TBD, 1A  | Stud jig. Accepts DO-4 and DO-5 stud packages.  |

**NOTE:** All of the above jigs are suitable for light research and development use. Consult Avtech ([info@avtechpulse.com](mailto:info@avtechpulse.com)) regarding the suitability of particular jigs for heavy production use.

## REGULATORY NOTES

### FCC PART 18

This device complies with part 18 of the FCC rules for non-consumer industrial, scientific and medical (ISM) equipment.

This instrument is enclosed in a rugged metal chassis and uses a filtered power entry module (where applicable). The main output signal is provided on a shielded connector that is intended to be used with shielded coaxial cabling and a shielded load. Under these conditions, the interference potential of this instrument is low.

If interference is observed, check that appropriate well-shielded cabling is used on the output connectors. Contact Avtech ([info@avtechpulse.com](mailto:info@avtechpulse.com)) for advice if you are unsure of the most appropriate cabling. Also, check that your load is adequately shielded. It may be necessary to enclose the load in a metal enclosure.

If any of the connectors on the instrument are unused, they should be covered with shielded metal "dust caps" to reduce the interference potential.

This instrument does not normally require regular maintenance to minimize interference potential. However, if loose hardware or connectors are noted, they should be tightened. Contact Avtech ([info@avtechpulse.com](mailto:info@avtechpulse.com)) if you require assistance.

### EC DECLARATION OF CONFORMITY



We                      Avtech Electrosystems Ltd.  
                             P.O. Box 5120, LCD Merivale  
                             Ottawa, Ontario  
                             Canada K2C 3H5

declare that this pulse generator meets the intent of Directive 2004/108/EG for Electromagnetic Compatibility. Compliance pertains to the following specifications as listed in the official Journal of the European Communities:

EN 50081-1 Emission

EN 50082-1 Immunity

and that this pulse generator meets the intent of the Low Voltage Directive 2006/95/EC. Compliance pertains to the following specifications as listed in the official Journal of the European Communities:

EN 61010-1:2001 Safety requirements for electrical equipment for measurement, control, and laboratory use

DIRECTIVE 2011/65/EU (RoHS)

We Avtech Electrosystems Ltd.  
P.O. Box 5120, LCD Merivale  
Ottawa, Ontario  
Canada K2C 3H5

declare that, to the best of our knowledge, all electrical and electronic equipment (EEE) sold by the company are in compliance with Directive 2011/65/EU of the European Parliament and of the Council of 8 June 2011 on the restriction of the use of certain hazardous substances in electrical and electronic equipment (also known as “RoHS Recast”). In addition, this declaration of conformity is issued under the sole responsibility of Avtech Electrosystems Ltd. Specifically, products manufactured do not contain the substances listed in the table below in concentrations greater than the listed maximum value.

| <i>Material/Substance</i>             | <i>Threshold level</i>    |
|---------------------------------------|---------------------------|
| Lead (Pb)                             | < 1000 ppm (0.1% by mass) |
| Mercury (Hg)                          | < 1000 ppm (0.1% by mass) |
| Hexavalent Chromium (Cr6+)            | < 1000 ppm (0.1% by mass) |
| Polybrominated Biphenyls (PBB)        | < 1000 ppm (0.1% by mass) |
| Polybrominated Diphenyl ethers (PBDE) | < 1000 ppm (0.1% by mass) |
| Cadmium (Cd)                          | < 100 ppm (0.01% by mass) |
| Bis(2-ethylhexyl) phthalate (DEHP)    | < 1000 ppm (0.1% by mass) |
| Butyl benzyl phthalate (BBP)          | < 1000 ppm (0.1% by mass) |
| Dibutyl phthalate (DBP)               | < 1000 ppm (0.1% by mass) |
| Diisobutyl phthalate (DIBP)           | < 1000 ppm (0.1% by mass) |

DIRECTIVE 2002/96/EC (WEEE)

European customers who have purchased this equipment directly from Avtech will have completed a “WEEE Responsibility Agreement” form, accepting responsibility for WEEE compliance (as mandated in Directive 2002/96/EC of the European Union and local

laws) on behalf of the customer, as provided for under Article 9 of Directive 2002/96/EC.

Customers who have purchased Avtech equipment through local representatives should consult with the representative to determine who has responsibility for WEEE compliance. Normally, such responsibilities will lie with the representative, unless other arrangements (under Article 9) have been made.

Requirements for WEEE compliance may include registration of products with local governments, reporting of recycling activities to local governments, and financing of recycling activities.

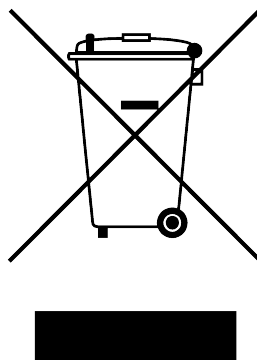

## FIRMWARE LICENSING

Instruments with firmware versions 5.00 or higher use open-source software internally. Some of this software requires that the source code be made available to the user as a condition of its licensing. This source code is available upon request (contact [info@avtechpulse.com](mailto:info@avtechpulse.com)).

Earlier firmware versions do not contain any open source software.

## INSTALLATION

### VISUAL CHECK

After unpacking the instrument, examine to ensure that it has not been damaged in shipment. Visually inspect all connectors, knobs, liquid crystal displays (LCDs), and the handles. If the instrument has been damaged, file a claim immediately with the company that transported the instrument.

The following items should be with the instrument:

- 1) A power cord.
- 2) A GPIB cable.
- 3) Two instrumentation manuals (this manual and the “Programming Manual for -B Instruments”).
- 4) One test jig, with a hinged lid.
- 5) A 2 meter DB-9 control cable.
- 6) Two 60 cm lengths of SMA-to-BNC cable.
- 7) Two 60 cm lengths of SMA-to-SMA cable.
- 8) One AVX-FILT-10NS accessory filter.
- 9) Units with -F8NS option only: One AVX-FILT-8NS accessory filter.
- 10) Units with -F12NS option only: One AVX-FILT-12NS accessory filter.
- 11) Units with -F20NS option only: One AVX-FILT-20NS accessory filter.

### POWER RATINGS

This instrument is intended to operate from 100 - 240 V, 50 - 60 Hz.

The maximum power consumption is 57 Watts. Please see the “FUSES” section for information about the appropriate AC and DC fuses.

This instrument is an “Installation Category II” instrument, intended for operation from a normal single-phase supply.

### CONNECTION TO THE POWER SUPPLY

An IEC-320 three-pronged recessed male socket is provided on the back panel for AC power connection to the instrument. One end of the detachable power cord that is supplied with the instrument plugs into this socket. The other end of the detachable power cord plugs into the local mains supply. Use only the cable supplied with the instrument. The mains supply must be earthed, and the cord used to connect the instrument to the mains supply must provide an earth connection. (The supplied cord does this.)

 Warning: Failure to use a grounded outlet may result in injury or death due to electric shock. This product uses a power cord with a ground connection. It must be connected to a properly grounded outlet. The instrument chassis is connected to the ground wire in the power cord.

The table below describes the power cord that is normally supplied with this instrument, depending on the destination region:

| Destination Region                             | Description                           | Option | Manufacturer | Part Number |
|--|---------------------------------------|--------|--------------|-------------|
| United Kingdom, Hong Kong, Singapore, Malaysia | BS 1363, 230V, 50 Hz                  | -AC00  | Qualtek      | 370001-E01  |
| Australia, New Zealand                         | AS 3112:2000, 230-240V, 50 Hz         | -AC01  | Qualtek      | 374003-A01  |
| Continental Europe, Korea, Indonesia, Russia   | European CEE 7/7 "Schuko" 230V, 50 Hz | -AC02  | Qualtek      | 364002-D01  |
| North America, Taiwan                          | NEMA 5-15, 120V, 60 Hz                | -AC03  | Qualtek      | 312007-01   |
| Switzerland                                    | SEV 1011, 230V, 50 Hz                 | -AC06  | Qualtek      | 378001-E01  |
| South Africa, India                            | SABS 164-1, 220-250V, 50 Hz           | -AC17  | Volex        | 2131H 10 C3 |
| Japan  | JIS 8303, 100V, 50-60 Hz              | -AC18  | Qualtek      | 397002-01   |
| Israel   | SI 32, 220V, 50 Hz                    | -AC19  | Qualtek      | 398001-01   |
| China  | GB 1002-1, 220V, 50 Hz                | -AC22  | Volex        | 2137H 10 C3 |

## PROTECTION FROM ELECTRIC SHOCK

 Operators of this instrument must be protected from electric shock at all times. The owner must ensure that operators are prevented access and/or are insulated from every connection point. In some cases, connections must be exposed to potential human contact. Operators must be trained to protect themselves from the risk of electric shock. This instrument is intended for use by qualified personnel who recognize shock hazards and are familiar with safety precautions required to avoid possibly injury. In particular, operators should:

1. Keep exposed high-voltage wiring to an absolute minimum.
2. Wherever possible, use shielded connectors and cabling.
3. Connect and disconnect loads and cables only when the instrument is turned off.

4. Keep in mind that all cables, connectors, oscilloscope probes, and loads must have an appropriate voltage rating.
5. Do not attempt any repairs on the instrument, beyond the fuse replacement procedures described in this manual. Contact Avtech technical support (see page 2 for contact information) if the instrument requires servicing. Service is to be performed solely by qualified service personnel.

#### ENVIRONMENTAL CONDITIONS

This instrument is intended for use under the following conditions:

1. indoor use;
2. altitude up to 2 000 m;
3. temperature 5 °C to 40 °C;
4. maximum relative humidity 80 % for temperatures up to 31 °C decreasing linearly to 50 % relative humidity at 40 °C;
5. Mains supply voltage fluctuations up to  $\pm 10$  % of the nominal voltage;
6. no pollution or only dry, non-conductive pollution.

## FUSES

This instrument contains four fuses. All are accessible from the rear-panel. Two protect the AC prime power input, and two protect the internal DC power supplies. The locations of the fuses on the rear panel are shown in the figure below:

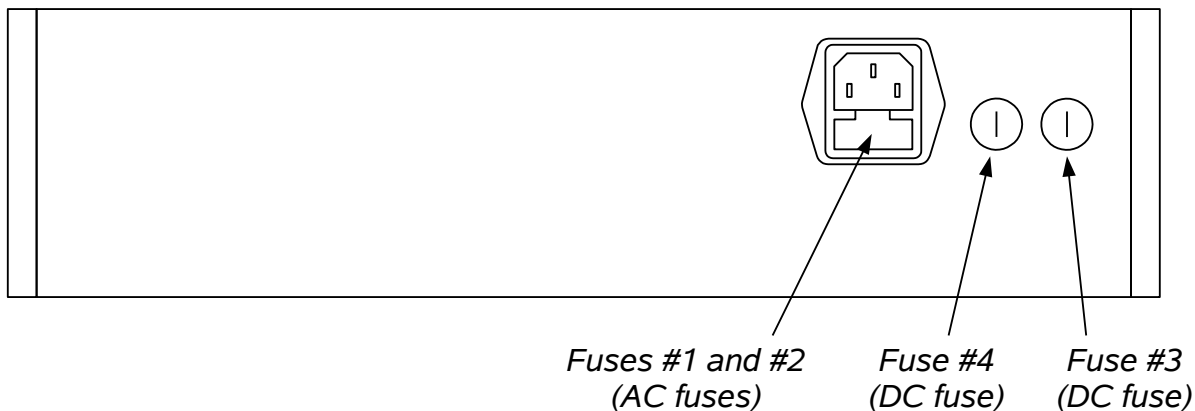

### AC FUSE REPLACEMENT

To physically access the AC fuses, the power cord must be detached from the rear panel of the instrument. The fuse drawer may then be extracted using a small flat-head screwdriver, as shown below:

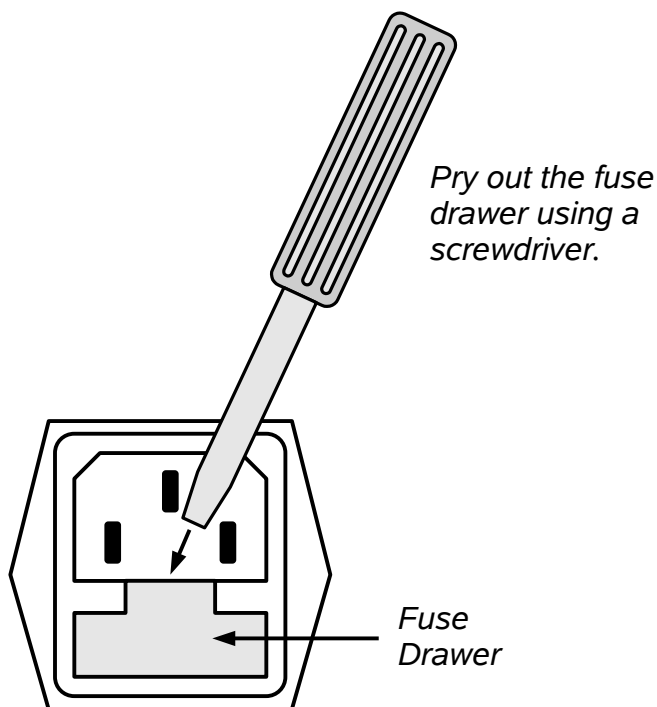



## DC FUSE REPLACEMENT

The DC fuses may be replaced by inserting the tip of a flat-head screwdriver into the fuse holder slot, and rotating the slot counter-clockwise. The fuse and its carrier will then pop out.

## FUSE RATINGS

The following table lists the required fuses:

| Fuses       | Nominal Mains Voltage | Rating                 | Case Size | Recommended Replacement Part |                       |
|-------------|-----------------------|------------------------|-----------|------------------------------|-----------------------|
|             |                       |                        |           | Littelfuse Part Number       | Digi-Key Stock Number |
| #1, #2 (AC) | 100-240V              | 0.5A, 250V, Time-Delay | 5×20 mm   | 0218.500HXP                  | F2416-ND              |
| #3 (DC)     | N/A                   | 1.0A, 250V, Time-Delay | 5×20 mm   | 0218001.HXP                  | F2419-ND              |
| #4 (DC)     | N/A                   | 0.5A, 250V, Time-Delay | 5×20 mm   | 0218.500HXP                  | F2416-ND              |

The recommended fuse manufacturer is Littelfuse (<http://www.littelfuse.com>).

Replacement fuses may be easily obtained from Digi-Key (<http://www.digikey.com>) and other distributors.

## FRONT PANEL CONTROLS

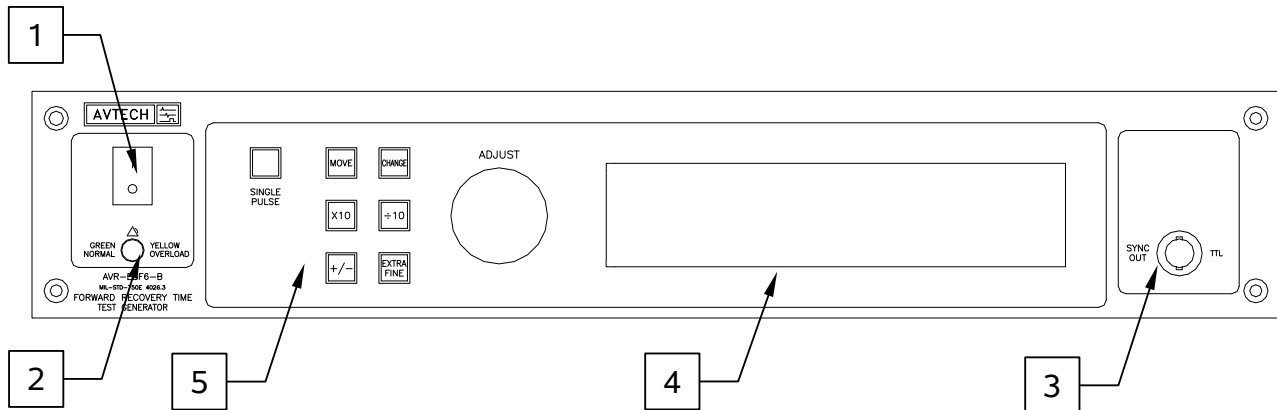

1. **POWER Switch.** This is the main power switch. When turning the instrument on, there is normally a delay of 10 seconds before anything is shown on the main display, as the internal operating system boots up.
2. **OVERLOAD Indicator.** When the instrument is powered, this indicator is normally green, indicating normal operation. If this indicator is yellow, an internal automatic overload protection circuit has been tripped. If the unit is overloaded (by operating at an exceedingly high duty cycle or by operating into a very low impedance), the protective circuit will disable the output of the instrument and turn the indicator light yellow. The light will stay yellow (i.e. output disabled) for about 5 seconds after which the instrument will attempt to re-enable the output (i.e. light green) for about 1 second. If the overload condition persists, the output will be disabled again (i.e. light yellow) for another 5 seconds. If the overload condition has been removed, the instrument will resume normal operation.

This overload indicator may flash yellow briefly at start-up. This is not a cause for concern.

3. **SYNC OUT.** This connector supplies a SYNC output that can be used to trigger other equipment, particularly oscilloscopes. This signal leads (or lags) the main output by a duration set by the "DELAY" controls and has an approximate amplitude of +3 Volts to  $R_L > 50\Omega$  with a pulse width of approximately 100 ns.
4. **LIQUID CRYSTAL DISPLAY (LCD).** This LCD is used in conjunction with the keypad to change the instrument settings. Normally, the main menu is displayed, which lists the key adjustable parameters and their current values. The "Programming Manual for -B Instruments" describes the menus and submenus in detail.

5. KEYPAD.

| Control Name | Function  |
|--------------|---|
| MOVE         | This moves the arrow pointer on the display.  |
| CHANGE       | This is used to enter the submenu, or to select the operating mode, pointed to by the arrow pointer.  |
| ×10          | If one of the adjustable numeric parameters is displayed, this increases the setting by a factor of ten.  |
| ÷10          | If one of the adjustable numeric parameters is displayed, this decreases the setting by a factor of ten.  |
| +/-          | If one of the adjustable numeric parameters is displayed, and this parameter can be both positive or negative, this changes the sign of the parameter.  |
| EXTRA FINE   | This changes the step size of the ADJUST knob. In the extra-fine mode, the step size is twenty times finer than in the normal mode. This button switches between the two step sizes.  |
| ADJUST       | This large knob adjusts the value of any displayed numeric adjustable values, such as frequency, pulse width, etc. The adjust step size is set by the "EXTRA FINE" button.<br><br>When the main menu is displayed, this knob can be used to move the arrow pointer. |

## REAR PANEL CONTROLS

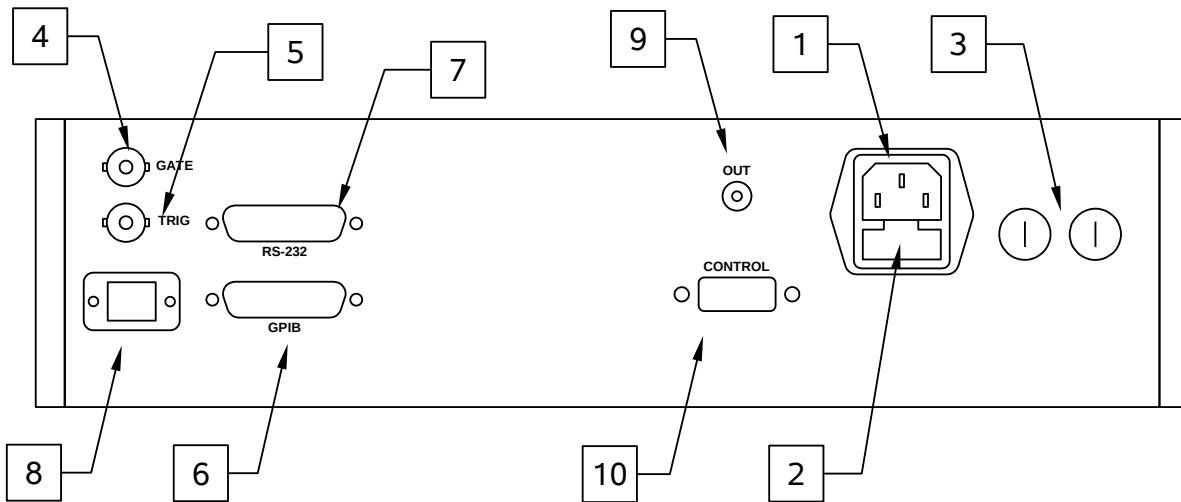

*Note: some connectors may be in different positions than shown above, depending on the exact combination of options ordered.*

1. **AC POWER INPUT.** An IEC-320 C14 three-pronged recessed male socket is provided on the back panel for AC power connection to the instrument. One end of the detachable power cord that is supplied with the instrument plugs into this socket.
2. **AC FUSE DRAWER.** The two fuses that protect the AC input are located in this drawer. Please see the “FUSES” section of this manual for more information.
3. **DC FUSES.** These two fuses protect the internal DC power supplies. Please see the “FUSES” sections of this manual for more information.
4. **GATE.** This TTL-level (0 and +5V) logic input can be used to gate the triggering of the instrument. This input can be either active high or active low, depending on the front panel settings or programming commands. (The instrument triggers normally when this input is unconnected). When set to active high mode, this input is pulled-down to ground by a 1 k $\Omega$  resistor. When set to active low mode, this input is pulled-up to +5V by a 1 k $\Omega$  resistor.
5. **TRIG.** This TTL-level (0 and +5V) logic input can be used to trigger the instrument, if the instrument is set to triggering externally. The instrument triggers on the rising edge of this input. The input impedance of this input is 1 k $\Omega$ . (Depending on the length of cable attached to this input, and the source driving it, it may be desirable to add a coaxial 50 Ohm terminator to this input to provide a proper transmission line termination. The Pasternack ([www.pasternack.com](http://www.pasternack.com)) PE6008-50 BNC feed-thru 50

Ohm terminator is suggested for this purpose.)

6. GPIB Connector. A standard GPIB cable can be attached to this connector to allow the instrument to be computer-controlled. See the “Programming Manual for -B Instruments” for more details on GPIB control.
7. RS-232 Connector. A standard serial cable with a 25-pin male connector can be attached to this connector to allow the instrument to be computer-controlled. A user name (“admin”) and a password (“default”, as shipped from the factory) are required when logging into a serial terminal session. The internal controller attempts to auto-sense the parity setting. It may be necessary to send a few return characters before attempting a login in order to provide enough data to allow this auto-sensing to work. (A standard Linux “agetty” process is used to implement serial control internally.) See the “Programming Manual for -B Instruments” for more details on RS-232 control.
8. Network Connector. This Ethernet connector allows the instrument to be remotely controlled using the VXI-11.3, ssh (secure shell), telnet, and http (web) protocols. See the “Programming Manual for -B Instruments” for more details.
9. PULSE OUT CONNECTOR. This SMA connector provides the pulse output signal to the rise time filter. This output should be connected to the corresponding input on the rise time filter using the supplied SMA-to-SMA coaxial cable.

 Caution: Voltages as high as 100V may be present on the center conductor of this output connector. Avoid touching this conductor. Connect to this connector using standard coaxial cable, to ensure that the center conductor is not exposed.

10. CONTROL Connector. This DB-9 female connector should be connected to the corresponding connector on the test jig using the supplied DB-9 cable. This cable contains the safety interlock signals that ensure that the test jig lid is closed.

## TIMING CONTROL

### BASIC TIMING CONTROL

This instrument can be triggered by its own internal clock or by an external TTL trigger signal. In either case, two output channels respond to the trigger: OUT and SYNC. The OUT channel is the signal that is applied to the load. Its amplitude and pulse width are variable. The SYNC pulse is a fixed-width TTL-level reference pulse used to trigger oscilloscopes or other measurement systems. When the delay is set to a positive value the SYNC pulse precedes the OUT pulse. When the delay is set to a negative value the SYNC pulse follows the OUT pulse.

These pulses are illustrated below, assuming internal triggering and a positive delay:

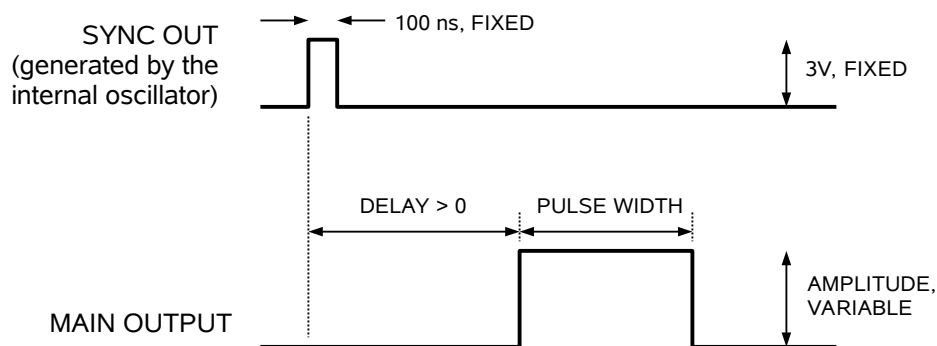

*Figure A*

If the delay is negative, the order of the SYNC and OUT pulses is reversed:

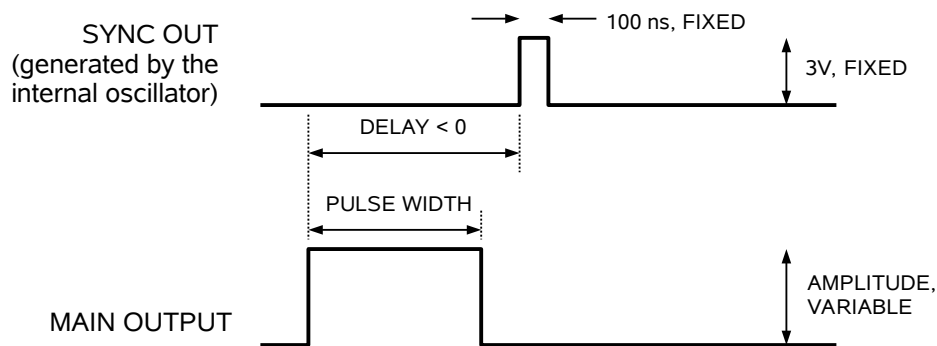

*Figure B*

The next figure illustrates the relationship between the signal when an external TTL-level trigger is used:

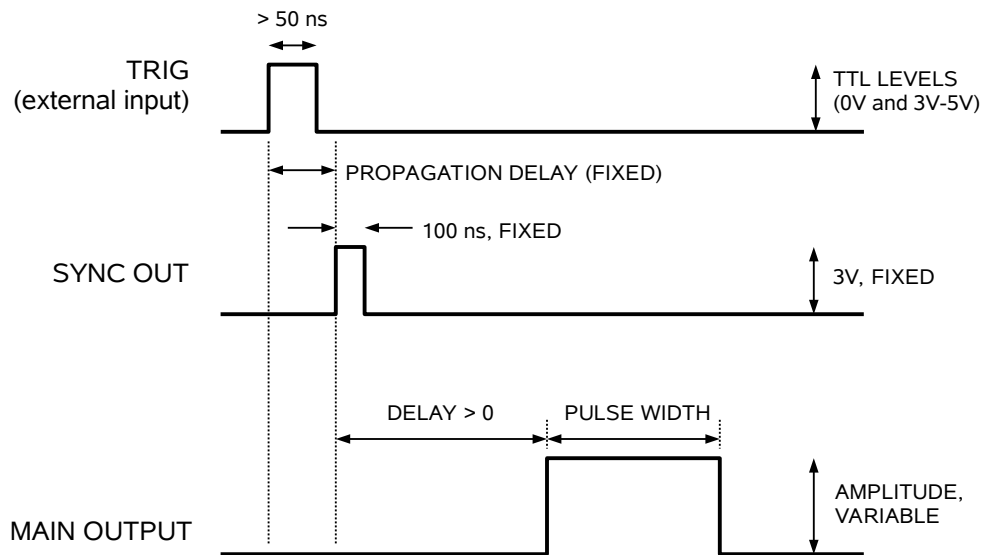

Figure C

As before, if the delay is negative, the order of the SYNC and OUT pulses is reversed.

## TRIGGER MODES

This instrument has four trigger modes:

- Internal Trigger: the instrument controls the trigger frequency, and generates the clock internally.
- External Trigger: the instrument is triggered by an external TTL-level clock on the back-panel TRIG connector.
- Manual Trigger: the instrument is triggered by the front-panel "SINGLE PULSE" pushbutton.
- Hold Trigger: the instrument is set to not trigger at all.

These modes can be selected using the front panel trigger menu, or by using the appropriate programming commands. (See the "Programming Manual for -B Instruments" for more details.)

## GATING MODES

Triggering can be suppressed by a TTL-level signal on the rear-panel GATE connector. The instrument can be set to stop triggering when this input high or low, using the front-panel gate menu or the appropriate programming commands. When gated, the output

will complete the full pulse width if the output is high, and then stop triggering. Pulses are not truncated.



## BASIC AMPLITUDE CONTROL

The basic test arrangement for the AVR-EBF6-B is shown in the figure below:

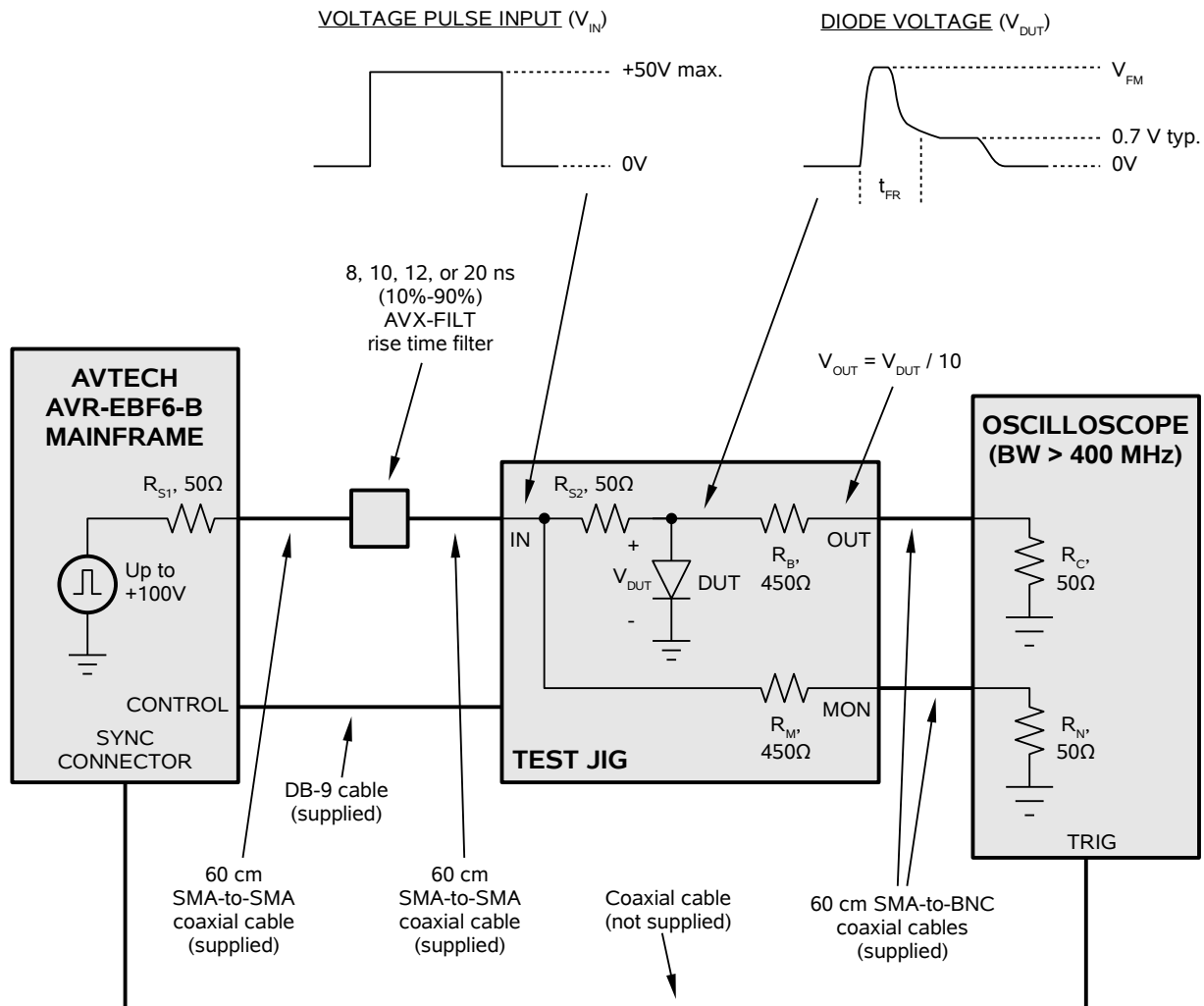

The mainframe connects to the rise time filter using a 60 cm length of SMA-to-SMA coaxial cable.

The output of the filter connects to the test jig using another 60 cm length of SMA-to-SMA coaxial cable.

A DB-9 control cable connects the mainframe to the test jig, to control the safety interlocks.

The test jig main output is fed into the 50 Ohm input of an oscilloscope by a 60 cm length of BNC-to-SMA coaxial cable, as is the monitor output.

The SYNC output of the mainframe should be used to trigger the oscilloscope.

 A 50 Ohm resistance ( $R_C$  in the diagram above) must be connected to ground on the output. This can be a discrete resistor, a feed-through terminator, or the input impedance of an oscilloscope (the latter method is shown in the diagram). If a high-speed sampling oscilloscope is used, the input should be protected by adding attenuator on the input.

The 450 Ohm resistance in series with the test jig output and the 50 Ohm input impedance of the oscilloscope form a 10:1 voltage, so the measured voltage is:

$$V_{OUT} = V_{DUT} / 10$$

The monitor output is similarly divided by a factor of 10, so that:

$$V_{MON} = V_{IN} / 10$$

The monitor output is provided so that the user may determine the starting point of the transient.

### SETTING THE AMPLITUDE LEVELS

The amplitude pulse may be set from the front panel of the instrument, or by computer command. This amplitude is expressed in terms of the voltage present on the test jig input.

The amplitude is related to the forward diode current by:

$$I_F \approx (V_{IN} - V_{DUT}) / 50\Omega$$

where  $V_{DUT}$  is the forward voltage drop of the diode (typically 0.7V for the classic silicon PN junction diode, and usually somewhat lower for a Schottky diode).

For instance, if the desired forward current amplitude is 500 mA, the amplitude should be set at 25.7V, so that  $(25.7V - 0.7V) / 50\Omega = 500$  mA. It may be necessary to adjust the amplitude iteratively to obtain the desired  $I_F$ , since  $V_{DUT}$  may not be known in advance.

### AMPLITUDE ACCURACY

 Due to the variations in  $V_F$  as a function of operating conditions, the amplitude settings *should not be relied upon for any degree of accuracy*. Instead the voltage at the OUT terminal on the test jig should be monitored with a calibrated oscilloscope.

$R_B$  can be measured directly on the test jig (with the test jig disconnected) to determine calibrated relationships, if desired.  $R_C$  is provided by the user, and can be calibrated as required.

### INCORRECT ORIENTATION

The instrument and the DUT will not be damaged if the diode is installed with the incorrect orientation (i.e., with the anode and cathode reversed). However, incorrect waveforms will be generated,

### CABLE LENGTHS

The cable lengths are not critical. They may be increased or decreased as desired.

The cables connecting the OUT and MON signals to the oscilloscope should have identical lengths, to avoid introducing timing skews.

### ACCESSIBLE VOLTAGES

The mainframe provides pulsed voltages of up to 100V to the test jig. For this reason, the output is automatically disabled when the test jig lid is open. The lid must be closed to obtain measurements.

 Shielded cabling should be used for all connections to the "IN" and "OUT" terminals on the test jig, and the "OUT" connector on the mainframe.

 When used properly (with  $R_C = 50$  Ohms), the maximum voltage on the OUT terminal will be  $< 1V$ , approximately. However, if  $R_C$  is not connected and the DUT is not installed, the maximum voltage will at the OUT terminal may be as high as 100V. You may need to consider whether this scenario would damage your oscilloscope, and take appropriate precautions.

## BASIC MEASUREMENT THEORY

The basic procedure for measuring the forward recovery voltage and time is described in method 4026.3 of MIL-STD-750E. The user should familiarize themselves with this method before using this instrument.

The basic parameters are shown in Figure 4026-1 of MIL-STD-750E, reproduced in part here:

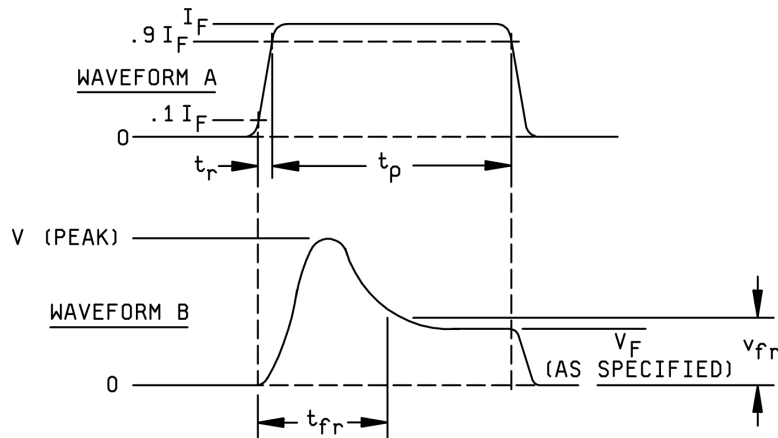

“Waveform B” in this figure is the voltage across the DUT,  $V_{DUT}$ . This is related to the OUT signal on the test jig by:

$$V_{OUT} = V_{DUT} / 10.$$

“Waveform A” in this figure is the current through the DUT,  $I_F$ . This is related to the OUT and MON signals on the test jig by:

$$I_F \approx (V_{IN} - V_{DUT}) / 50\Omega$$

$$I_F \approx (10 \times V_{MON} - 10 \times V_{OUT}) / 50\Omega$$

The above figure shows  $t_{fr}$  as the time between  $0.1 I_F$  and  $V_{fr}$ .

Unfortunately, the text also says  $t_{fr}$  is “measured from the time forward voltage becomes positive to the time that forward voltage recovers to a specified  $v_{fr}$ ”, which is slightly different. The “time forward voltage becomes positive” is before the time where  $0.1 I_F$  is reached.

In practice, it is impossible to measure the “time forward voltage becomes positive” repeatably.  $0.1 I_F$  is a much easier time to identify and measure in an automated system.

In the test results included in later sections, the approximation that  $0.1 I_F$  occurs at  $0.1 V_{IN}$  (or  $0.1 V_{MON}$ ) is used to simplify measurements. This provides conservative results,

since  $0.1 I_F$  actually occurs slightly after  $0.1 V_{IN}$ . This will slightly increase the measured  $t_{FR}$  value.

If you prefer to not use this approximation, you will need to use the math functions of your oscilloscope to identify  $0.1 (V_{MON} - V_{OUT})$ , rather than  $0.1 V_{MON}$ .

## TEST JIG MECHANICAL ASPECTS

### ALL TEST JIGS

The IN, MON, OUT, and CONTROL connectors are on the rear of the jig, below the hinges:



### AVX-TFR-MIX TEST JIG

One AVX-TFR-MIX test jig is normally supplied with the mainframe, unless the customer has requested a different or additional test jigs.

The AVX-TFR-MIX test jig accepts a range of through-hole and axial devices, using pin sockets and spring-loaded pins. It is intended for use with diodes in DO-41, TO-220, DO-204AR, TO-3 or similar packages. A photo of the arrangement is shown below:

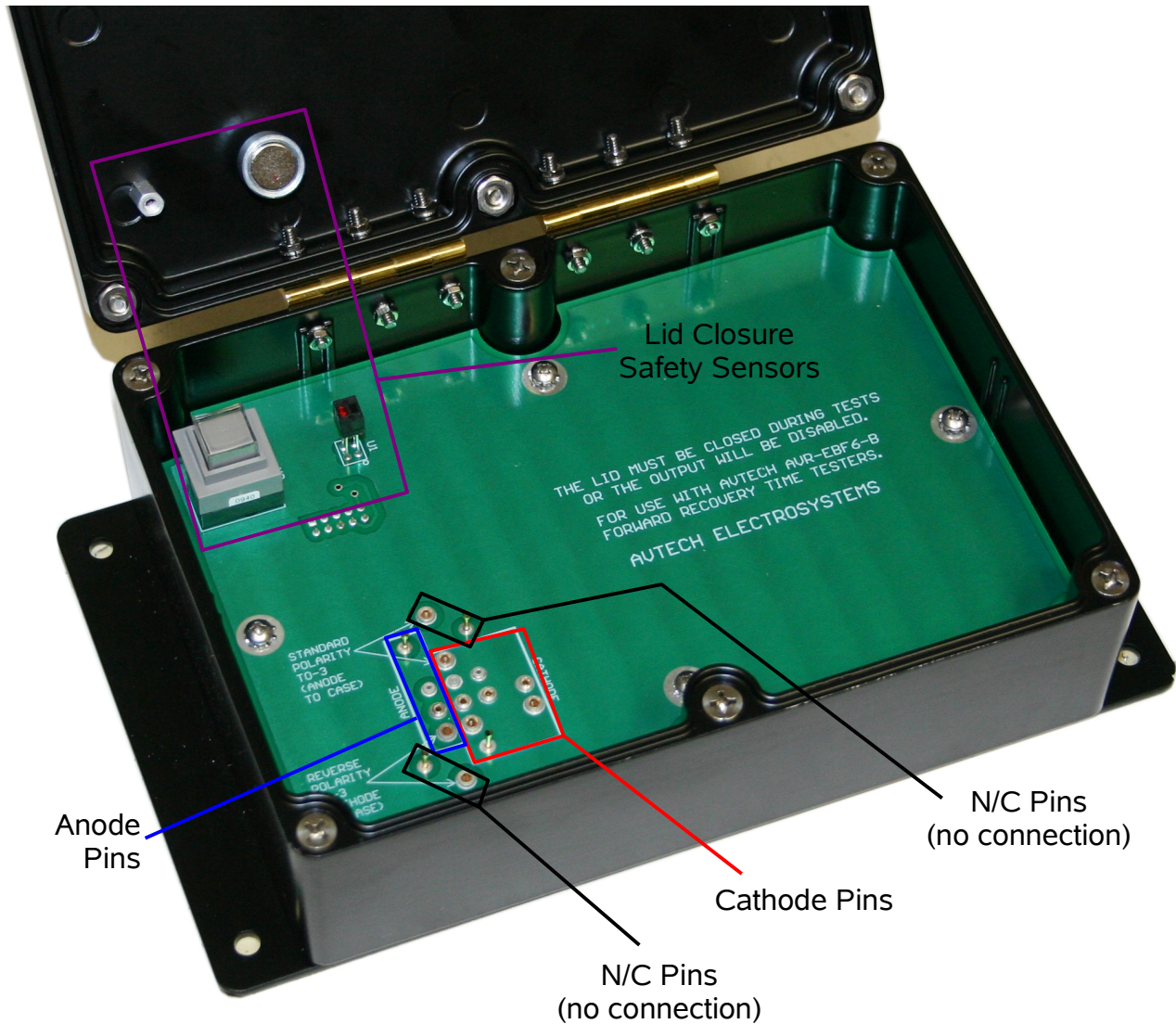

The instrument and the DUT will not be damaged if the diode is installed with the incorrect orientation (i.e., with the anode and cathode reversed). However, incorrect waveforms will be generated.

The procedure for inserting most axial and TO-220 packages is straightforward. Simply insert the DUT between one of the Anode pin sockets (in the blue area above) and one of the Cathode sockets (in the red area above). Select the sockets with the most appropriate hole size, and try to minimize all lead lengths, to minimize parasitic inductance.

This jig will also accommodate a number of TO-3 configurations, outlined below. If the case is connected to the anode, and the pin(s) are used for the cathode, the arrangement shown below must be used:

This socket and spring pin provide mechanical support only. They are not electrically active.

This spring pin must contact the underside of the case. It provides the anode connection.

The cathode pin of interest must be inserted into this socket. For dual-diode devices, rotate the TO-3 package so that the desired diode cathode is inserted here.

**For TO-3 packages  
with Case = Anode**

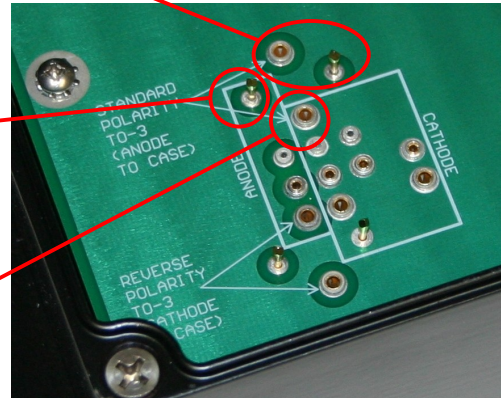

If the case is connected to the cathode, and the pin(s) are used for the anode, the arrangement shown below must be used:

**For TO-3 packages  
with Case = Cathode**

The anode pin of interest must be inserted into this socket. For dual-diode devices, rotate the TO-3 package so that the desired diode anode is inserted here.

This socket and spring pin provide mechanical support only. They are not electrically active.

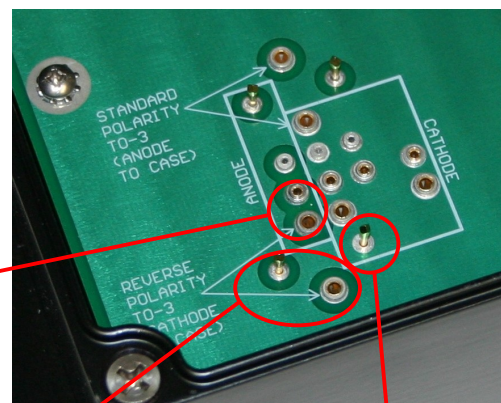

This spring pin must contact the underside of the case. It provides the cathode connection.



## SPECIALTY TEST JIGS

### AVX-TFR-SOD123W

The AVX-TFR-SOD123W test jig will accept SOD123W packages. To install a DUT, open the main (black) lid like this:

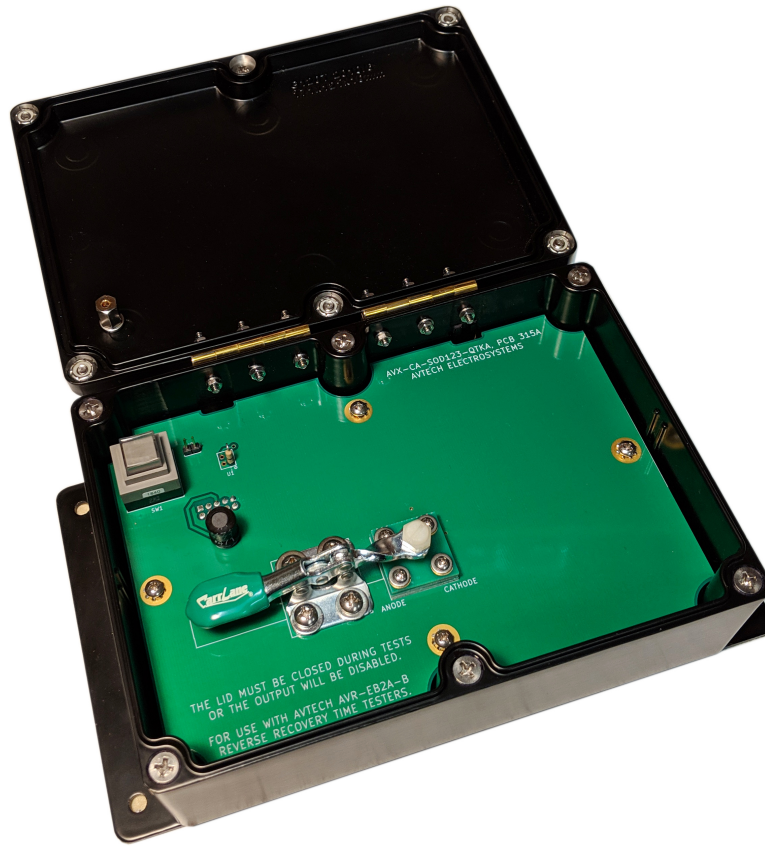

Raise the green lever on the left. This will raise the nylon screw over the DUT area on the right:

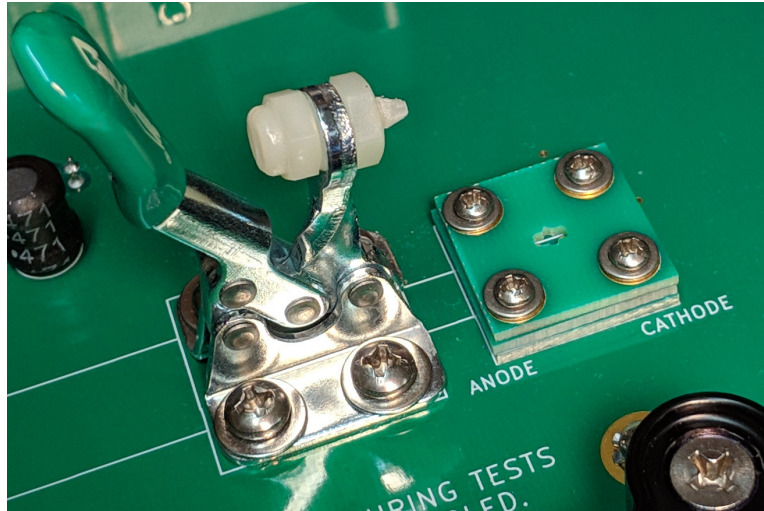

Using tweezers, position a DUT in the cavity of the raised circuit boards. Slots are provided for tweezer access. The DUT will rest on two spring pins, one contacting each DUT pad:

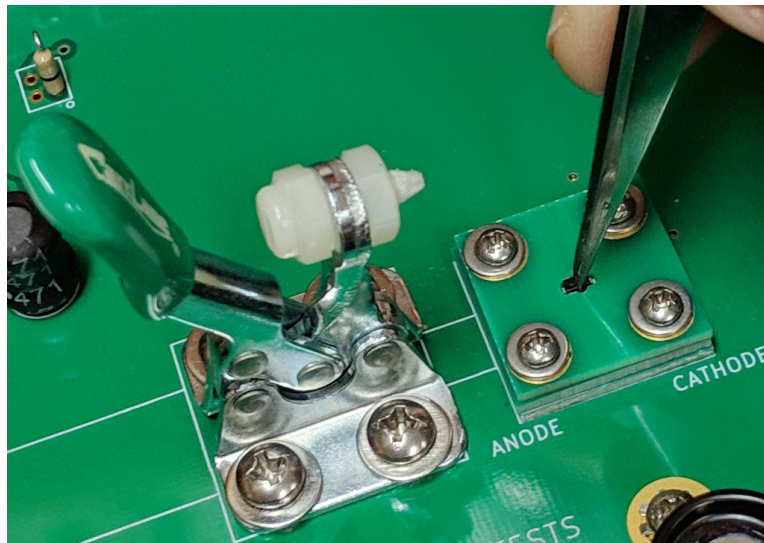

The cathode should be on the right. The anode should be on the left.

Lower the green lever on the left. This will lower the nylon screw over the DUT area on the right, and gently lock the DUT in place in the cavity:

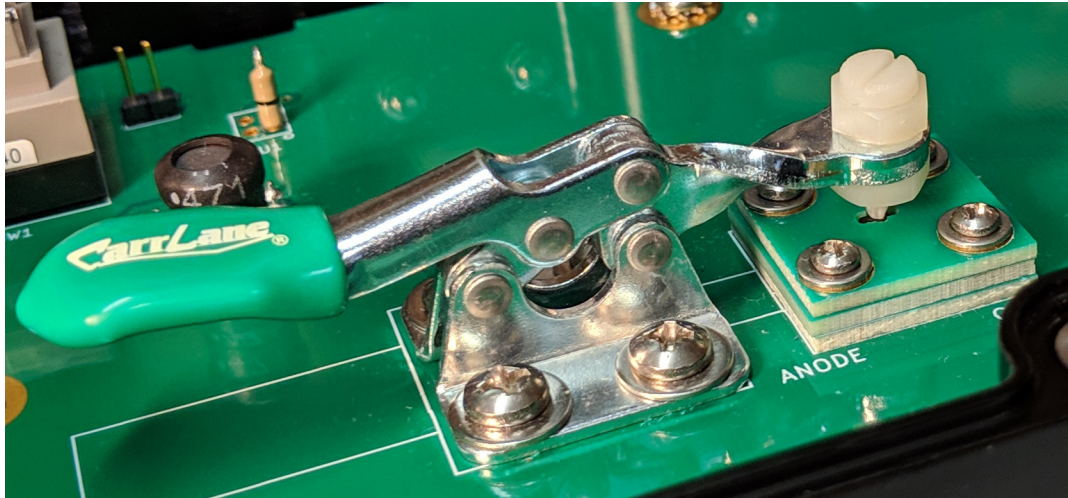

It is possible to use a screwdriver to adjust the positioning of the nylon screw. This will vary the maximum mechanical pressure applied to the DUT. The lever should snap into place when fully down, with a firm locking effect. It may be necessary to occasionally adjust this screw.

Once the DUT is installed in the socket, close the main lid. It must be closed for proper operation.

#### AVX-TFR-SOD128

The AVX-TFR-SOD128 is mostly identical to the AVX-TFR-SOD123W described above, except the dimensions of the DUT cavity are slightly different. It accepts SOD128 packages, rather than SOD123W packages.

## TYPICAL RESULTS

Obtaining meaningful results with the AVR-EBF6-B requires care, experience, and an understanding of diode transient behavior and the impact of inductive and capacitive parasitics. To assist the user, typical results are provided below. The user should be able to reliably duplicate these results.

Additional test results are provided at the end of this manual, generated using the actual shipped instrument and the specific jig(s) supplied with the instrument.

### 1N5811 RESULTS

A customer-supplied 1N5811 engineering sample (sample #51) was tested in the AVX-TRF-ANB jig, using the 8 ns, 10 ns, and 12 ns rise time filters, with the amplitude set to +25.7V (such that the forward current  $I_F = 500$  mA). The following forward recovery waveforms were obtained from the test jig outputs:

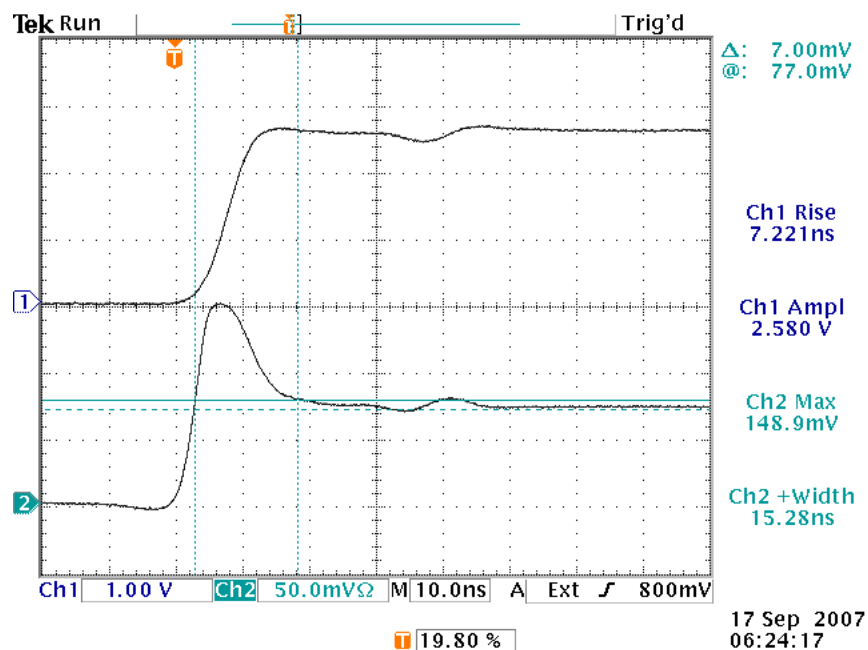

Top – Test jig MON output ( $V_{IN}/10$ , +25.7V, with ~ 8 ns rise time). 1 V/div, 10 ns/div.  
 Bottom – Test jig main output ( $V_{DUT}/10$ ). 50 mV/div, 10 ns/div.

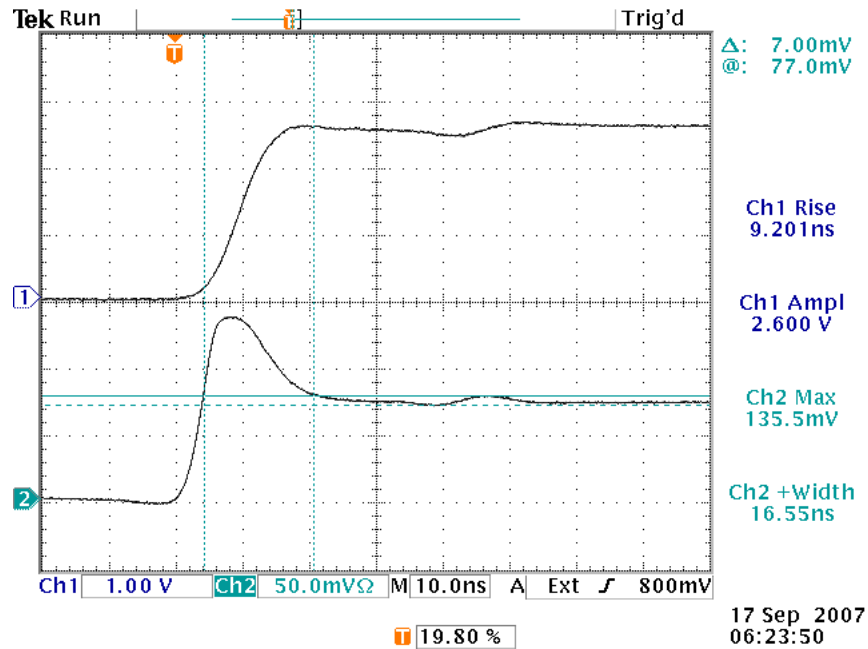

Top – Test jig MON output ( $V_{IN}/10$ , +25.7V, with ~ 10 ns rise time). 1 V/div, 10 ns/div.  
 Bottom – Test jig main output ( $V_{DUT}/10$ ). 50 mV/div, 10 ns/div.

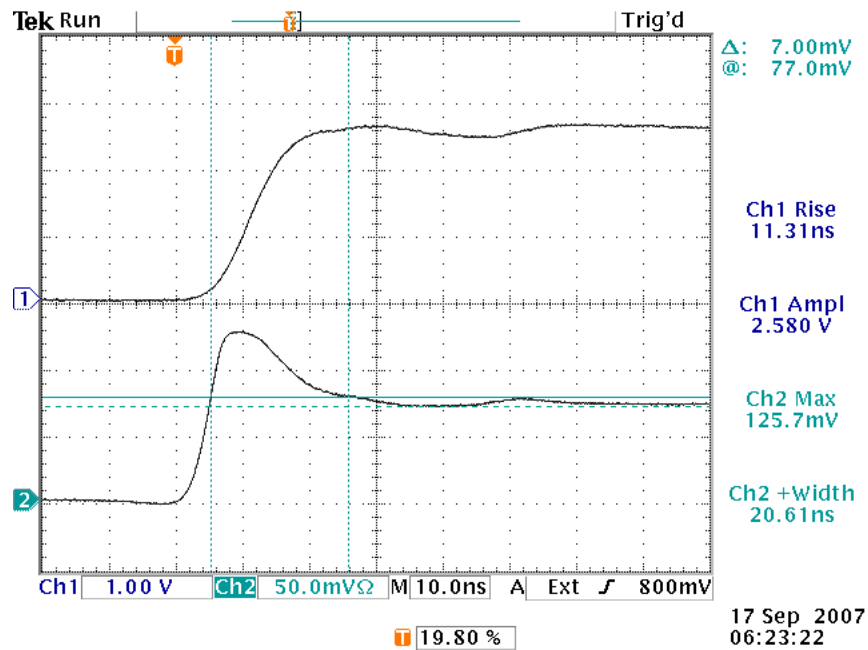

Top – Test jig MON output ( $V_{IN}/10$ , +25.7V, with ~ 12 ns rise time). 1 V/div, 10 ns/div.  
 Bottom – Test jig main output ( $V_{DUT}/10$ ). 50 mV/div, 10 ns/div.

The results are summarized in the following table:

| <b>Filter Used</b> | <b><math>V_{FM}</math></b> | <b><math>V_F</math></b> | <b><math>t_{FR}</math></b> |
|--------------------|----------------------------|-------------------------|----------------------------|
| 8 ns               | 1.489 V                    | 0.70 V                  | 15.28 ns                   |
| 10 ns              | 1.355 V                    | 0.70 V                  | 16.55 ns                   |
| 12 ns              | 1.257 V                    | 0.70 V                  | 20.61 ns                   |

## MQ1N5811US RESULTS

The Microsemi MQ1N5811US was tested with the amplitude set to +25.7V (such that the forward current  $I_F = 500$  mA), using an 8 ns rise time filter and the AVX-TFR-MELF test jig. The following forward recovery waveform was obtained at the test jig "OUT" terminal:

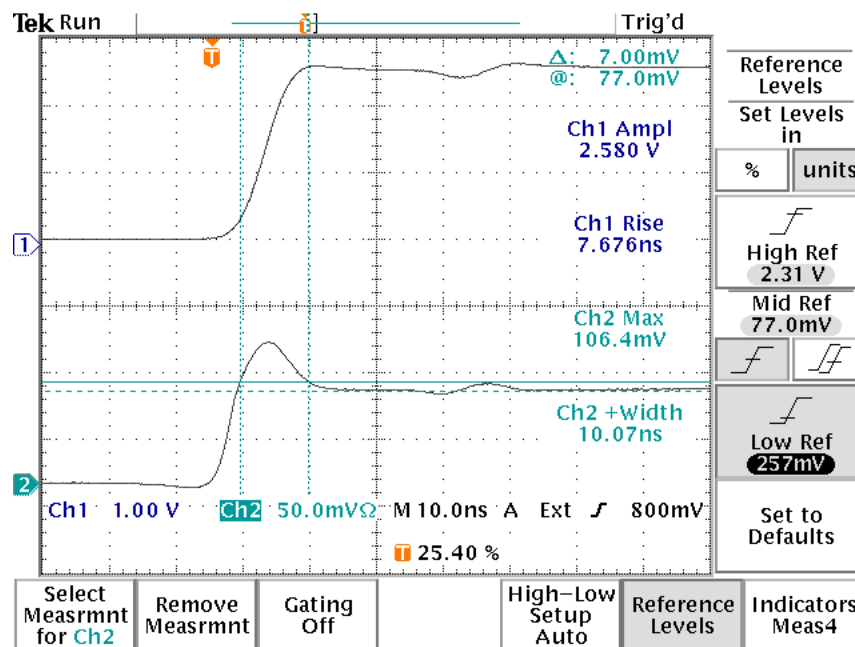

Top – Test jig MON output ( $V_{IN}/10$ , +25.7V, with ~ 8 ns rise time). 1 V/div, 10 ns/div.  
 Bottom – Test jig main output ( $V_{DUT}/10$ ). 50 mV/div, 10 ns/div.

Under these conditions,  $V_{FM} = 1.064$  V,  $V_F = 0.70$  V, and  $t_{FR} = 10.07$  ns (measured at  $1.1 \times V_F$ ).

## TROUBLESHOOTING

If you obtain “strange” output waveforms, or unexpected values of  $t_{RR}$ , keep these points in mind:

- 1) The test jig output *must* be terminated with 50 Ohms.
- 2) Keep device lead lengths as short as possible, to minimize parasitic inductance.
- 3) The test jig lid must be closed, or the pulser output will be disabled.

For technical support, contact [info@avtechpulse.com](mailto:info@avtechpulse.com). Sample waveforms and digital photos of your setup are always helpful!

## PROGRAMMING YOUR PULSE GENERATOR

### KEY PROGRAMMING COMMANDS

The “Programming Manual for -B Instruments” describes in detail how to connect the pulse generator to your computer, and the programming commands themselves. A large number of commands are available; however, normally you will only need a few of these. Here is a basic sample sequence of commands that might be sent to the instrument after power-up:

|                         |  |
|-------------------------|--|
| *rst                    | (resets the instrument)                        |
| trigger:source internal | (selects internal triggering)                  |
| frequency 1000 Hz       | (sets the frequency to 1000 Hz)                |
| pulse:delay 1 us        | (sets the delay to 1 us)                       |
| pulse:width 10 us       | (sets the positive pulse width to 10 us)       |
| volt:ampl +25.7         | (sets the positive pulse amplitude to +25.7 V) |
| output on               | (turns on the output)                          |

For triggering a single event, this sequence would be more appropriate:

|                          |   |
|--------------------------|---|
| *rst                     | (resets the instrument)                           |
| trigger:source hold      | (turns off all triggering)                        |
| output on                | (turns on the output)                             |
| pulse:delay 1 us         | (sets the delay to 1 us)                          |
| pulse:width 10 us        | (sets the positive pulse width to 10 us)          |
| volt:ampl +25.7          | (sets the positive pulse amplitude to +25.7 V)    |
| trigger:source immediate | (generates a single non-repetitive trigger event) |
| trigger:source hold      | (turns off all triggering)                        |
| output off               | (turns off the output)                            |

To set the instrument to trigger from an external TTL signal applied to the rear-panel TRlg connector, use:

|                         |  |
|-------------------------|--|
| *rst                    | (resets the instrument)                        |
| trigger:source external | (selects external triggering)                  |
| pulse:delay 1 us        | (sets the delay to 1 us)                       |
| pulse:width 10 us       | (sets the positive pulse width to 10 us)       |
| volt:ampl +25.7         | (sets the positive pulse amplitude to +25.7 V) |
| output on               | (turns on the output)                          |

These commands will satisfy 90% of your programming needs.



## ALL PROGRAMMING COMMANDS

For more advanced programmers, a complete list of the available commands is given below. These commands are described in detail in the “Programming Manual for -B Instruments”. (Note: this manual also includes some commands that are not implemented in this instrument. They can be ignored.)

| <u>Keyword</u> | <u>Parameter</u>   | <u>Notes</u>                     |
|----------------|--|----------------------------------|
| OUTPut:        |  |                                  |
| :[STATe]       | <boolean value>  |                                  |
| :PROTection    |  |                                  |
| :TRIPped?      |  | [query only]                     |
| [SOURce]:      |  |                                  |
| :FREQuency     |  |                                  |
| [:CW   FIXed]  | <numeric value>  |                                  |
| [SOURce]:      |  |                                  |
| :PULSe         |  |                                  |
| :PERiod        | <numeric value>  |                                  |
| :WIDTh         | <numeric value>  |                                  |
| :DELay         | <numeric value>  |                                  |
| :GATE          |  |                                  |
| :LEVel         | High   LOw   |                                  |
| [SOURce]:      |  |                                  |
| :VOLTage       |  |                                  |
| [:LEVel]       |  |                                  |
| [:IMMediate]   |  |                                  |
| [:AMPLitude]   | <numeric value>  |                                  |
| :PROTection    |  |                                  |
| :TRIPped?      |  | [query only]                     |
| STATUS:        |  |                                  |
| :OPERation     |  |                                  |
| :[EVENT]?      |  | [query only, always returns "0"] |
| :CONDition?    |  | [query only, always returns "0"] |
| :ENABle        | <numeric value>  | [implemented but not useful]     |
| :QUEStionable  |  |                                  |
| :[EVENT]?      |  | [query only, always returns "0"] |
| :CONDition?    |  | [query only, always returns "0"] |
| :ENABle        | <numeric value>  | [implemented but not useful]     |
| SYSTem:        |  |                                  |
| :COMMunicate   |  |                                  |
| :GPIB          |  |                                  |
| :ADDReSS       | <numeric value>  |                                  |
| :SERial        |  |                                  |
| :CONTRol       |  |                                  |
| :RTS           | ON   IBFull   RFR  |                                  |
| :[RECeive]     |  |                                  |
| :BAUD          | 1200   2400   4800   9600   19200   38400   57600   115200 |                                  |
| :ERRor         |  |                                  |
| :[NEXT]?       |  | [query only]                     |
| :COUNT?        |  | [query only]                     |
| :VERSion?      |  | [query only]                     |
| TRIGger:       |  |                                  |
| :SOURce        | INTernal   EXTernal   MANual   HOLD   IMMEDIATE            |                                  |
| *CLS           |  | [no query form]                  |
| *ESE           | <numeric value>  |                                  |

|       |                 |                 |
|-------|-----------------|-----------------|
| *ESR? |                 | [query only]    |
| *IDN? |                 | [query only]    |
| *OPC  |                 |                 |
| *SAV  | 0   1   2   3   | [no query form] |
| *RCL  | 0   1   2   3   | [no query form] |
| *RST  |                 | [no query form] |
| *SRE  | <numeric value> |                 |
| *STB? |                 | [query only]    |
| *TST? |                 | [query only]    |
| *WAI  |                 | [no query form] |

## MECHANICAL INFORMATION

### TOP COVER REMOVAL

If necessary, the interior of the instrument may be accessed by removing the four Phillips screws on the top panel. With the four screws removed, the top cover may be slid back (and off).

 Always disconnect the power cord and allow the instrument to sit unpowered for 10 minutes before opening the instrument. This will allow any internal stored charge to discharge.

There are no user-adjustable internal circuits. For repairs other than fuse replacement, please contact Avtech (info@avtechpulse.com) to arrange for the instrument to be returned to the factory for repair. Service is to be performed solely by qualified service personnel.

 Caution: High voltages are present inside the instrument during normal operation. Do not operate the instrument with the cover removed.

### RACK MOUNTING

A rack mounting kit is available. The -R5 rack mount kit may be installed after first removing the one Phillips screw on the side panel adjacent to the front handle.

### ELECTROMAGNETIC INTERFERENCE

To prevent electromagnetic interference with other equipment, all used outputs should be connected to shielded loads using shielded coaxial cables. Unused outputs should be terminated with shielded coaxial terminators or with shielded coaxial dust caps, to prevent unintentional electromagnetic radiation. All cords and cables should be less than 3m in length.

## MAINTENANCE

### REGULAR MAINTENANCE

This instrument does not require any regular maintenance.

On occasion, one or more of the four rear-panel fuses may require replacement. All fuses can be accessed from the rear panel. See the “FUSES” section for details.

### CLEANING

If desired, the interior of the instrument may be cleaned using compressed air to dislodge any accumulated dust. (See the “TOP COVER REMOVAL” section for instructions on accessing the interior.) No other cleaning is recommended.

### TRIGGER DAMAGE

The rear-panel TRIG input, used in the external trigger mode, is protected by a diode clamping circuit. However, the protection circuit is not foolproof, and it is possible for a grossly excessive signal to damage the trigger circuitry on the main timing control board (the 4×10 inch board on the right side of the instrument).

The IC that is most likely to fail under these conditions is installed in a socket. It is a standard TTL IC in a 16-pin plastic DIP package, model 74F151 or equivalent.

If you suspect that this IC has been damaged, turn off the power and replace this IC. It may be replaced by a 74F151, 74LS151, 74ALS151, or 74HCT151.

# WIRING DIAGRAMS

## WIRING OF AC POWER

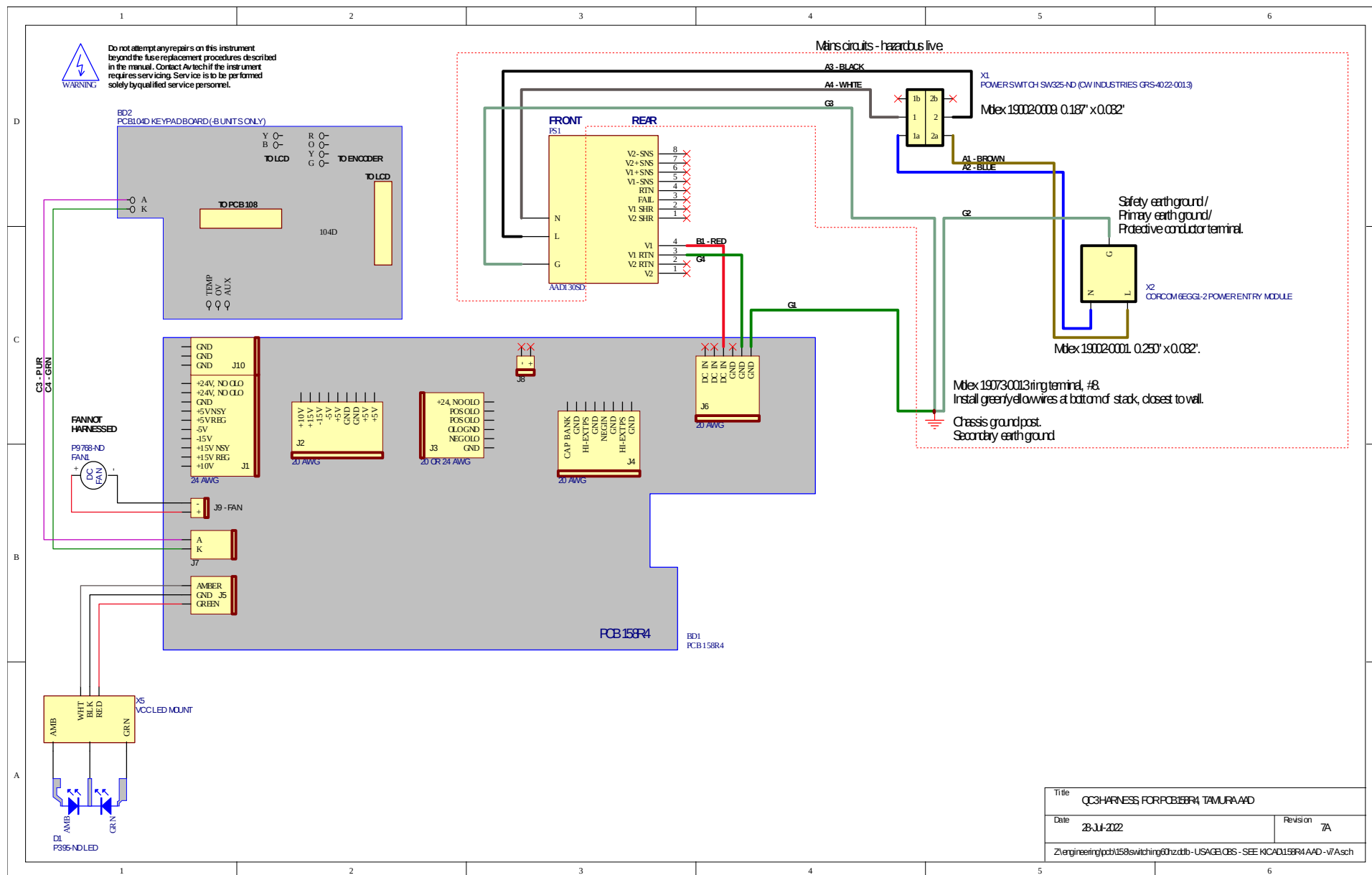

|   |             |                                   |    |
|---|-------------|-----------------------------------|----|
| Title   |             | QC3 HARNESS FOR PCB158R4 TAMURAAD |    |
| Date  | 28-JUL-2022 | Revision                          | 7A |
| Z:\engineering\pcb\158switching04hz.dtb - USAG/CSB - SEE KICAD\158R4AAD-V7A.sch |             |                                   |    |

# PCB 158R4 - LOW VOLTAGE POWER SUPPLY

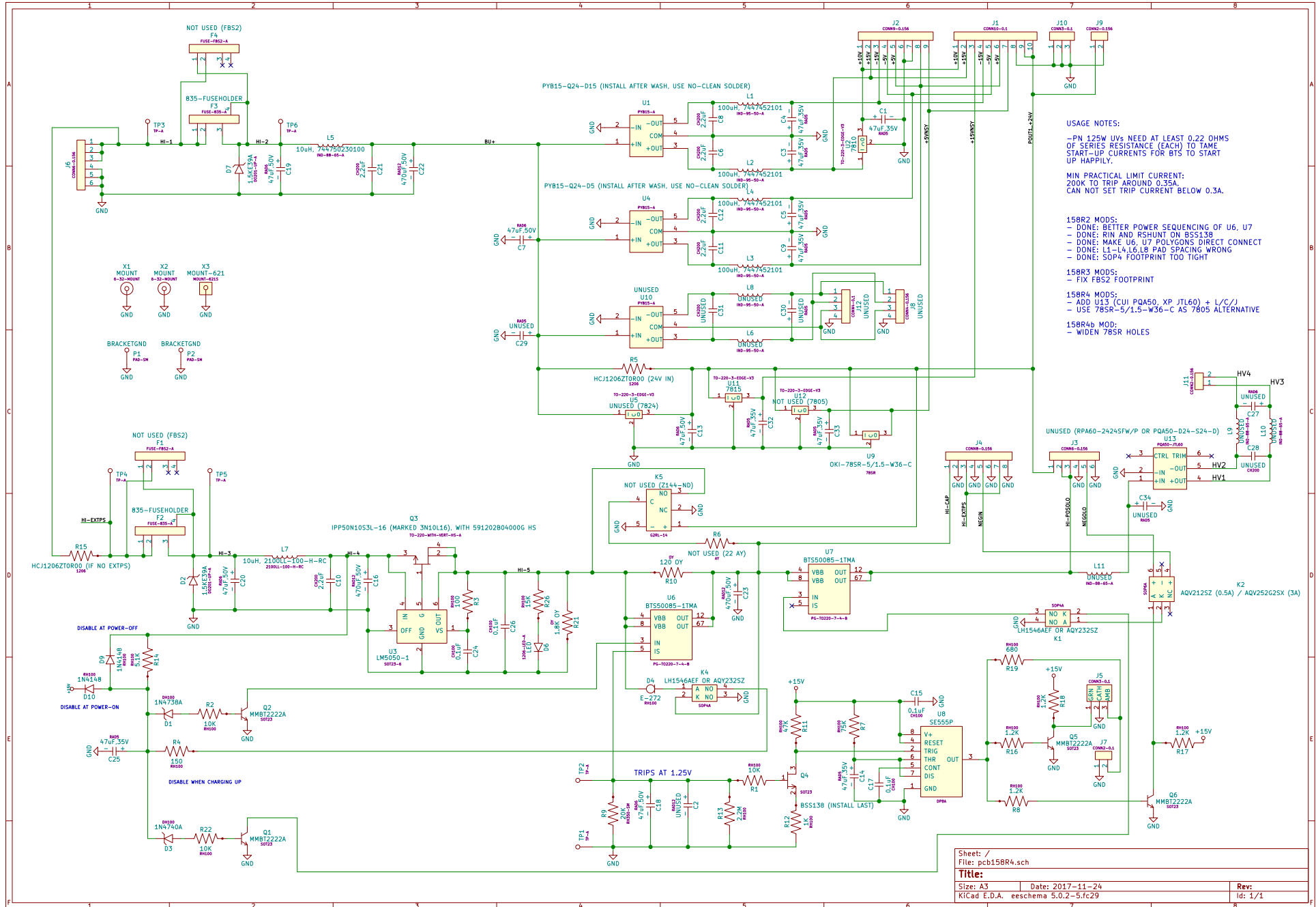

# PCB 235D - HIGH VOLTAGE DC POWER SUPPLY

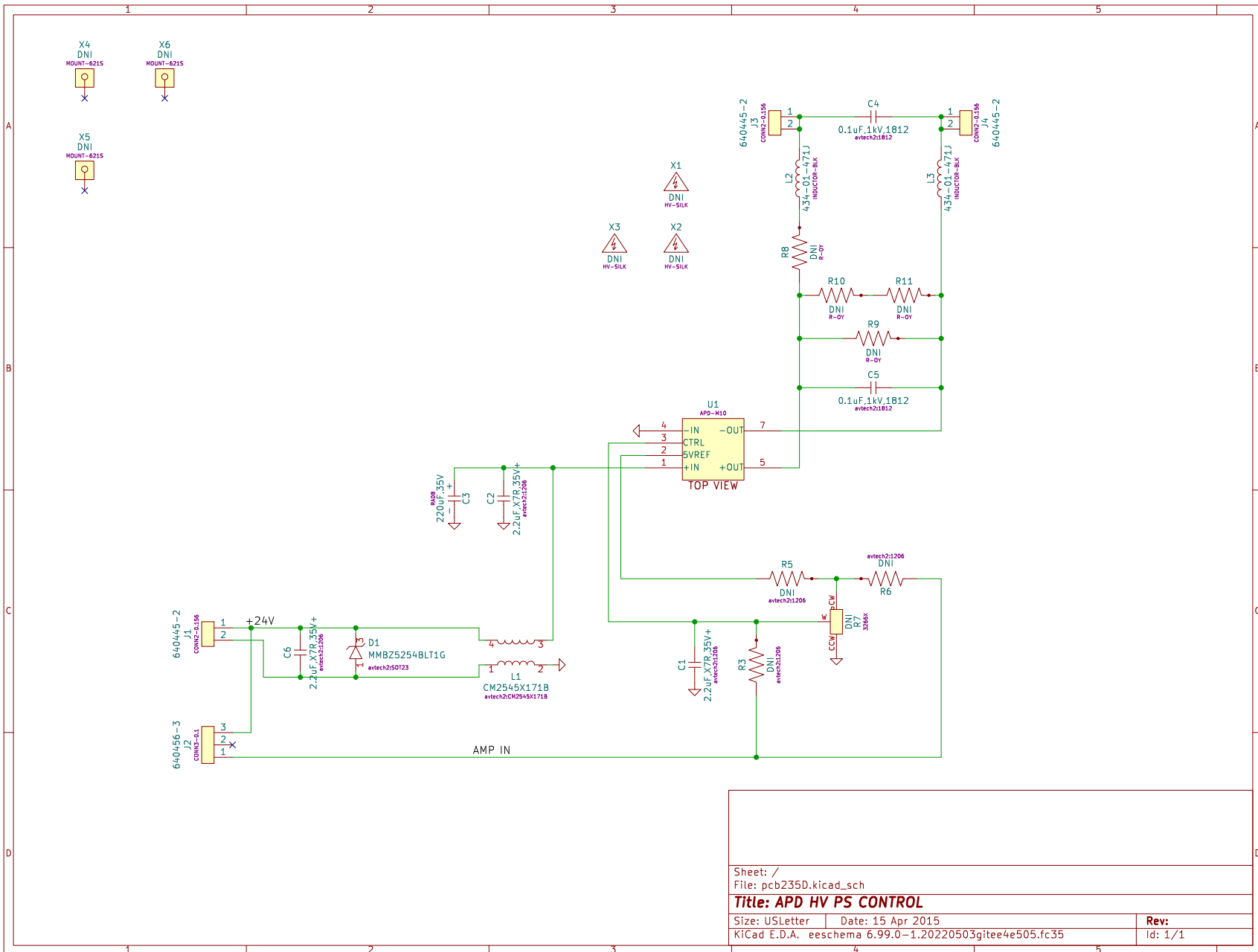

|  |                   |         |
|--|-------------------|---------|
| Sheet: /   |                   |         |
| File: pcb235D.kicad_sch                                |                   |         |
| <b>Title: APD HV PS CONTROL</b>                        |                   |         |
| Size: USLetter   | Date: 15 Apr 2015 | Rev:    |
| KiCad E.D.A. eeschema 6.99.0-1.20220503gitee4e505.fc35 |                   | Id: 1/1 |

# PCB 104H - KEYPAD / DISPLAY BOARD

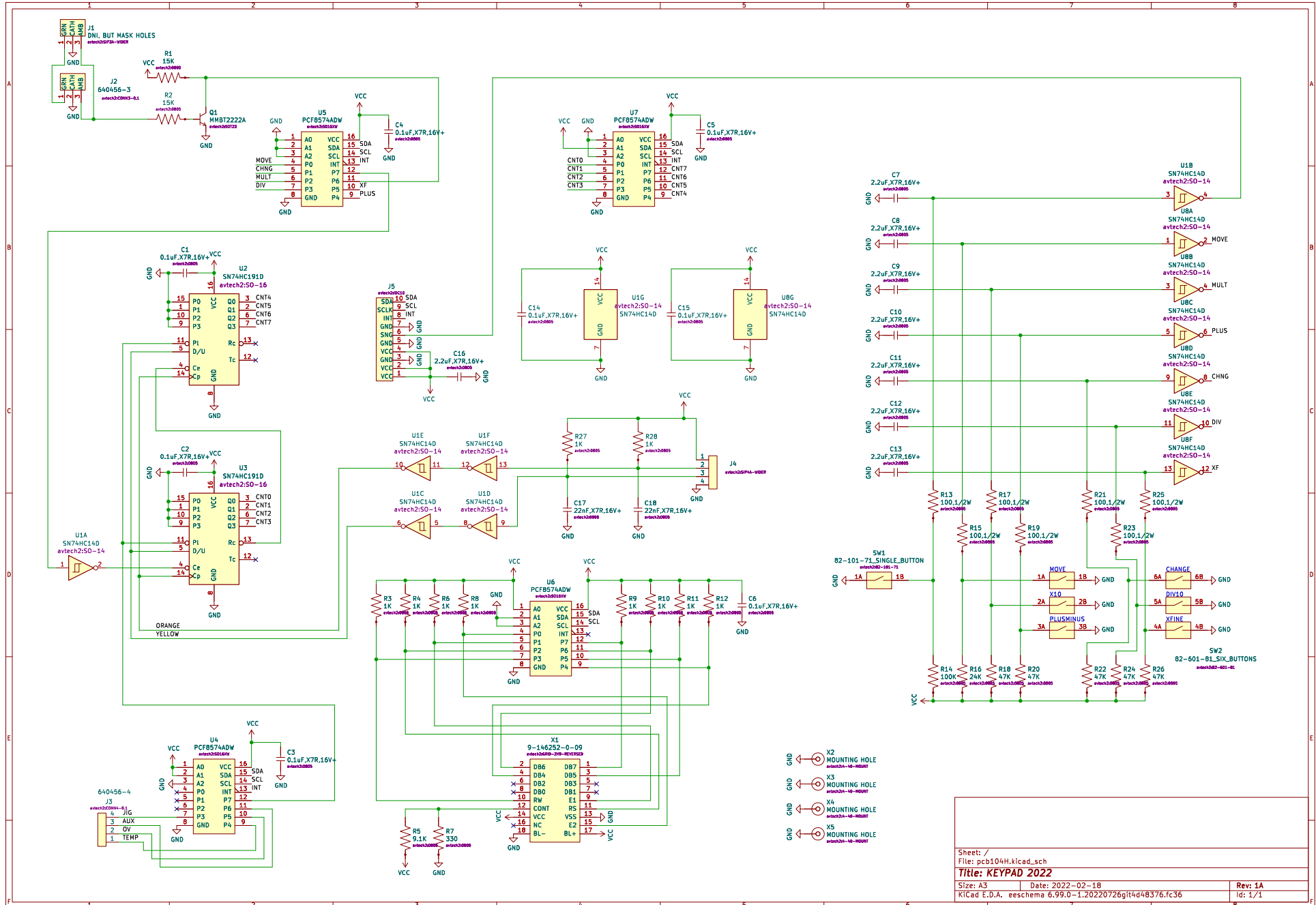



# PCB 201C - INTERLOCK CONTROL

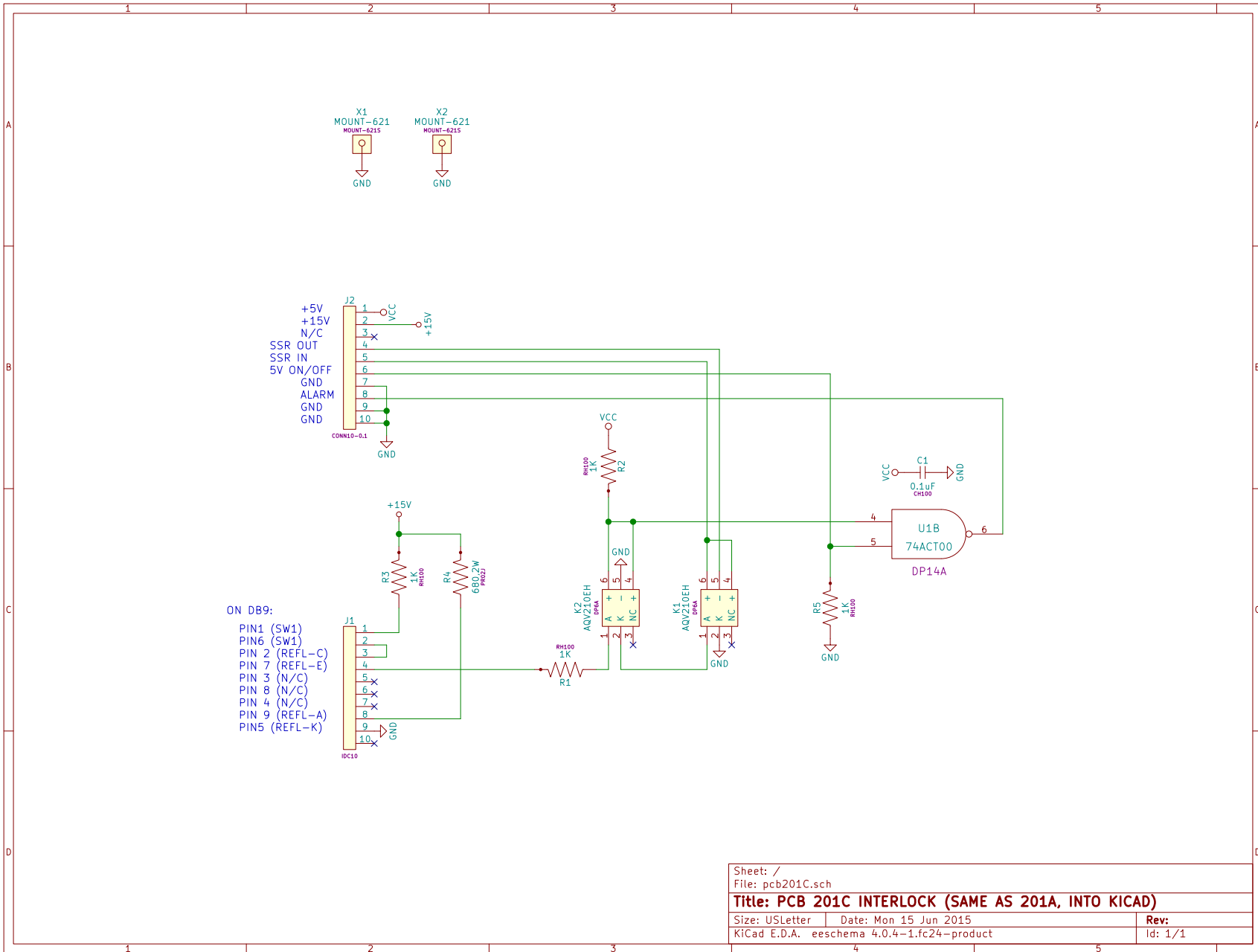

|   |                       |         |
|---|-----------------------|---------|
| Sheet: /  |                       |         |
| File: pcb201C.sch   |                       |         |
| <b>Title: PCB 201C INTERLOCK (SAME AS 201A, INTO KICAD)</b> |                       |         |
| Size: USLetter  | Date: Mon 15 Jun 2015 | Rev:    |
| KiCad E.D.A. eeschema 4.0.4-1.fc24-product                  |                       | Id: 1/1 |

# MAIN WIRING

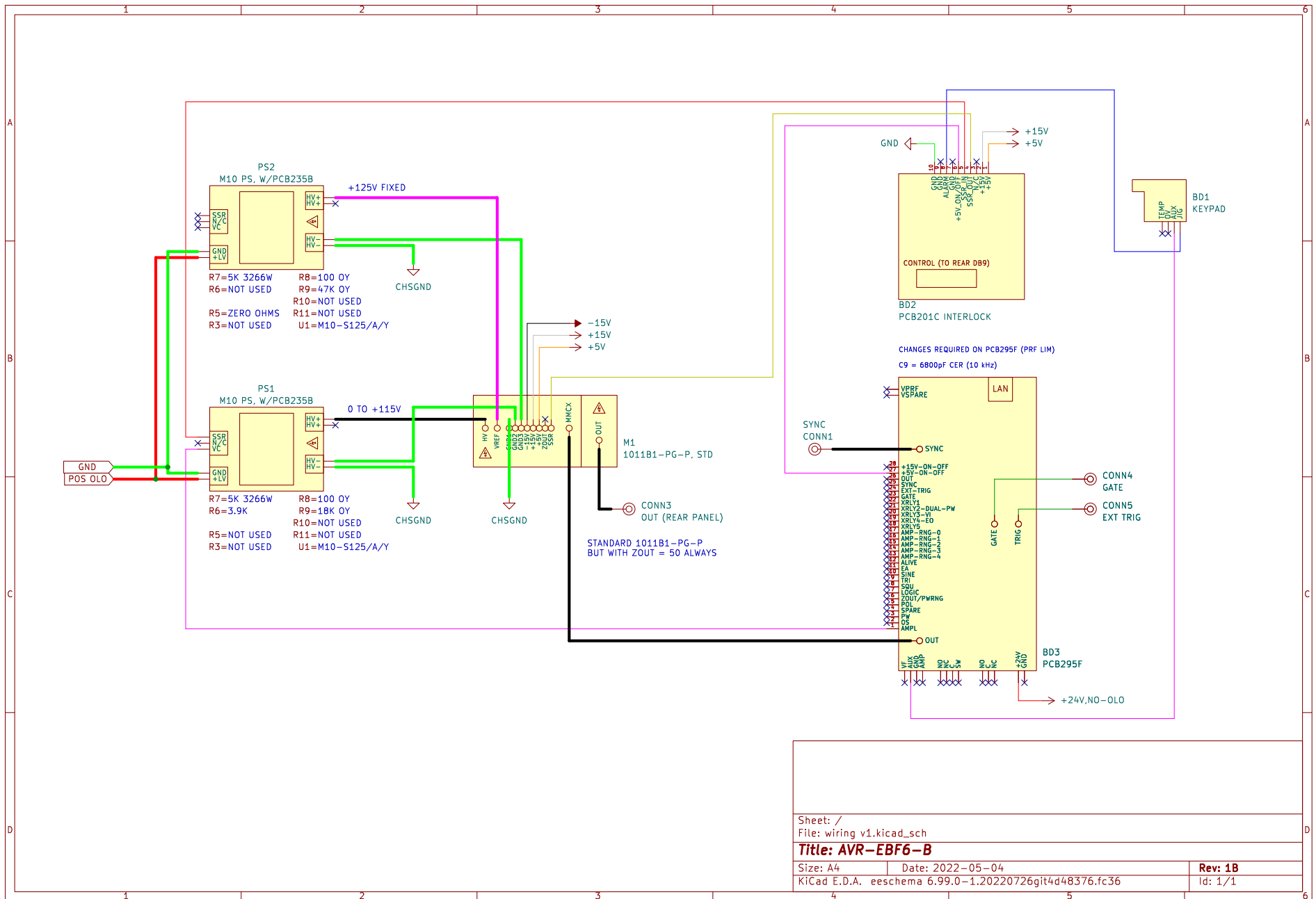

# TEST JIG WIRING (AVX-TFR-MIX)

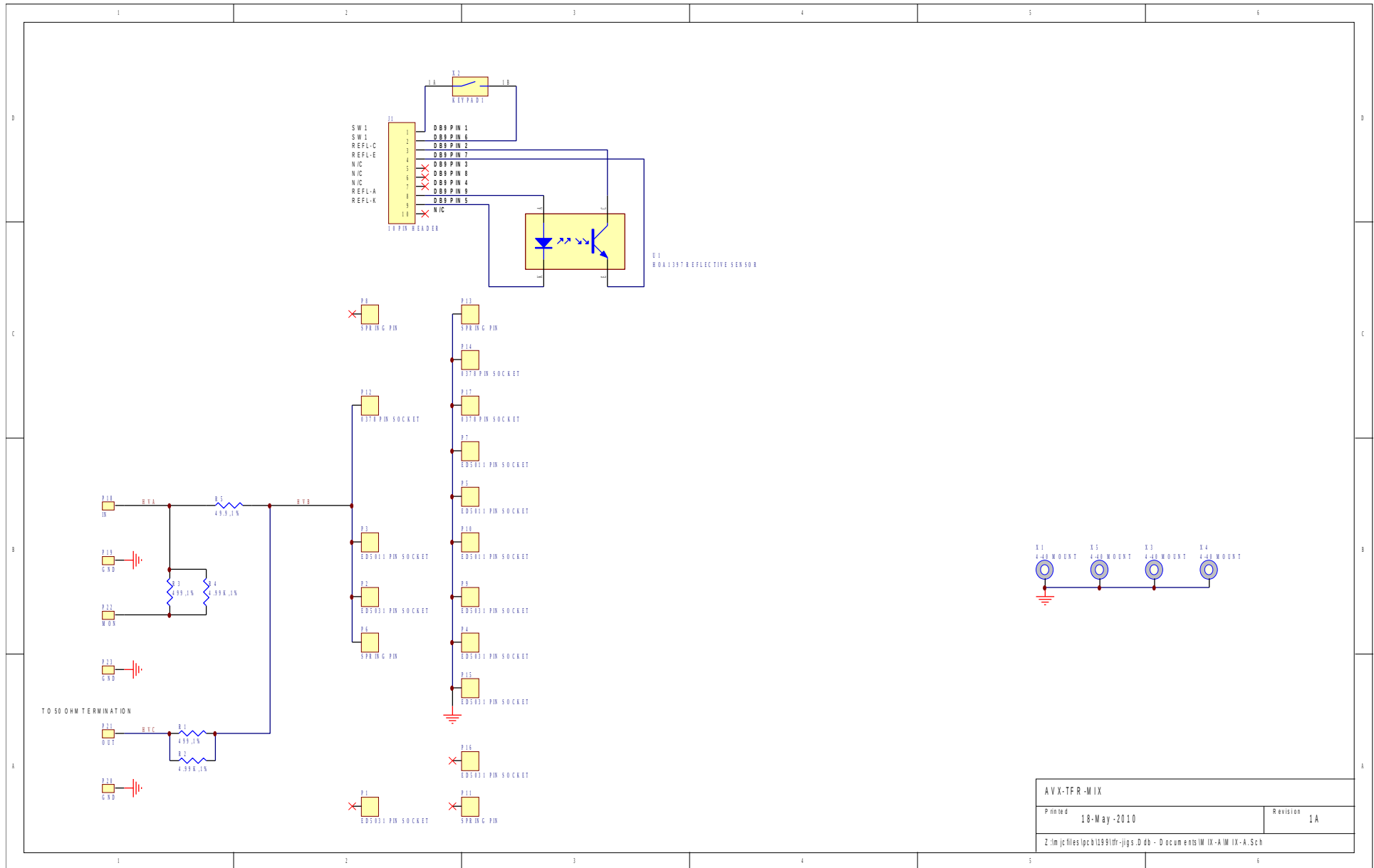

|  |             |
|--|-------------|
| AVX-TFR-MIX  |             |
| Printed 18-May-2010  | Revision 1A |
| Z:\m\jc\files\pcb\1291tfr-jigs.Ddb - Documents\W IX-A\W IX-A.Sch |             |

# TEST JIG WIRING (AVX-TFR-SOD123W)

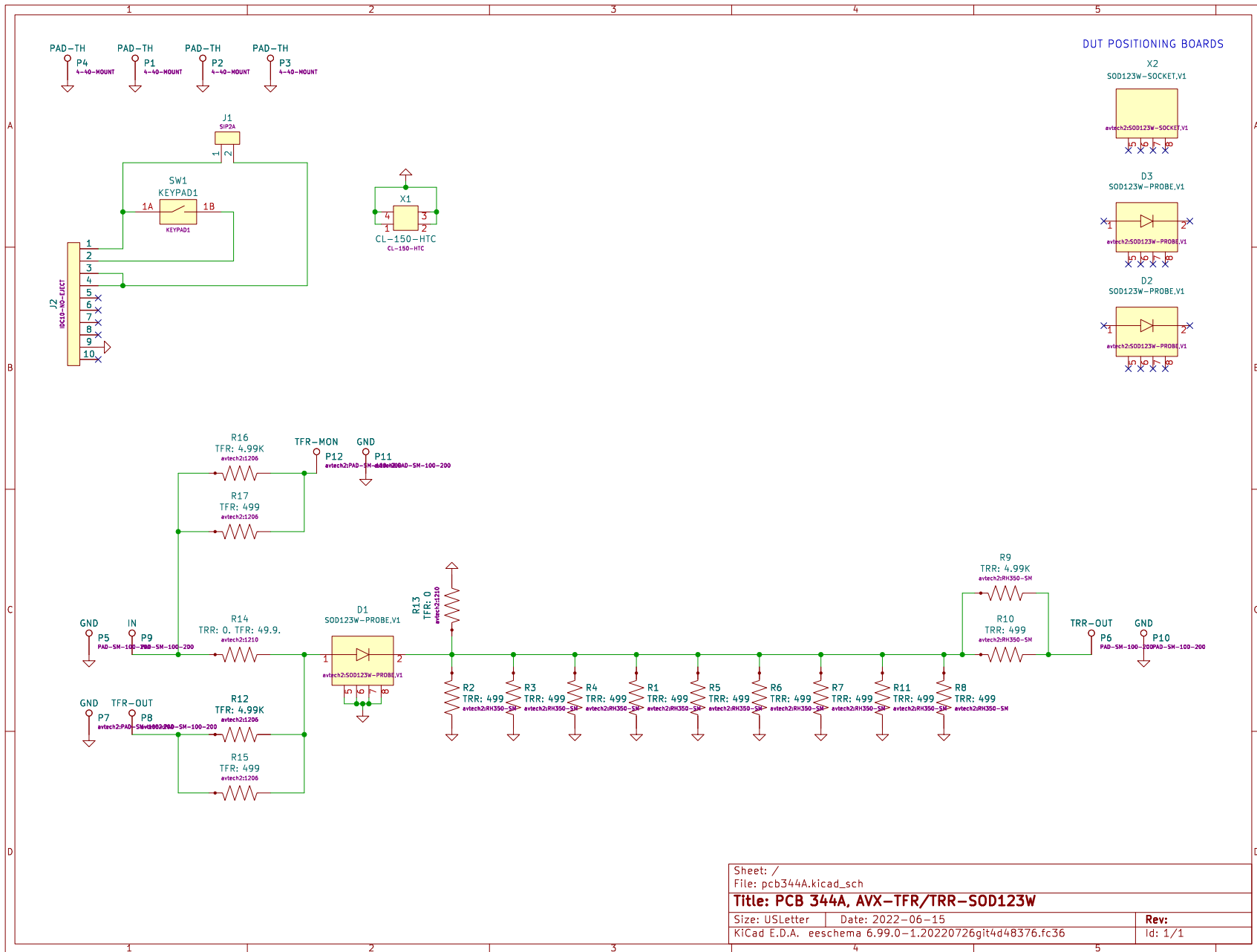

|  |                  |         |
|--|------------------|---------|
| Sheet: /   |                  |         |
| File: pcb344A.kicad_sch                                |                  |         |
| <b>Title: PCB 344A, AVX-TFR/TRR-SOD123W</b>            |                  |         |
| Size: USLetter   | Date: 2022-06-15 | Rev:    |
| KiCad E.D.A. eeschema 6.99.0-1.20220726git4d48376.fc36 |                  | Id: 1/1 |

# TEST JIG WIRING (AVX-TFR-SOD128)

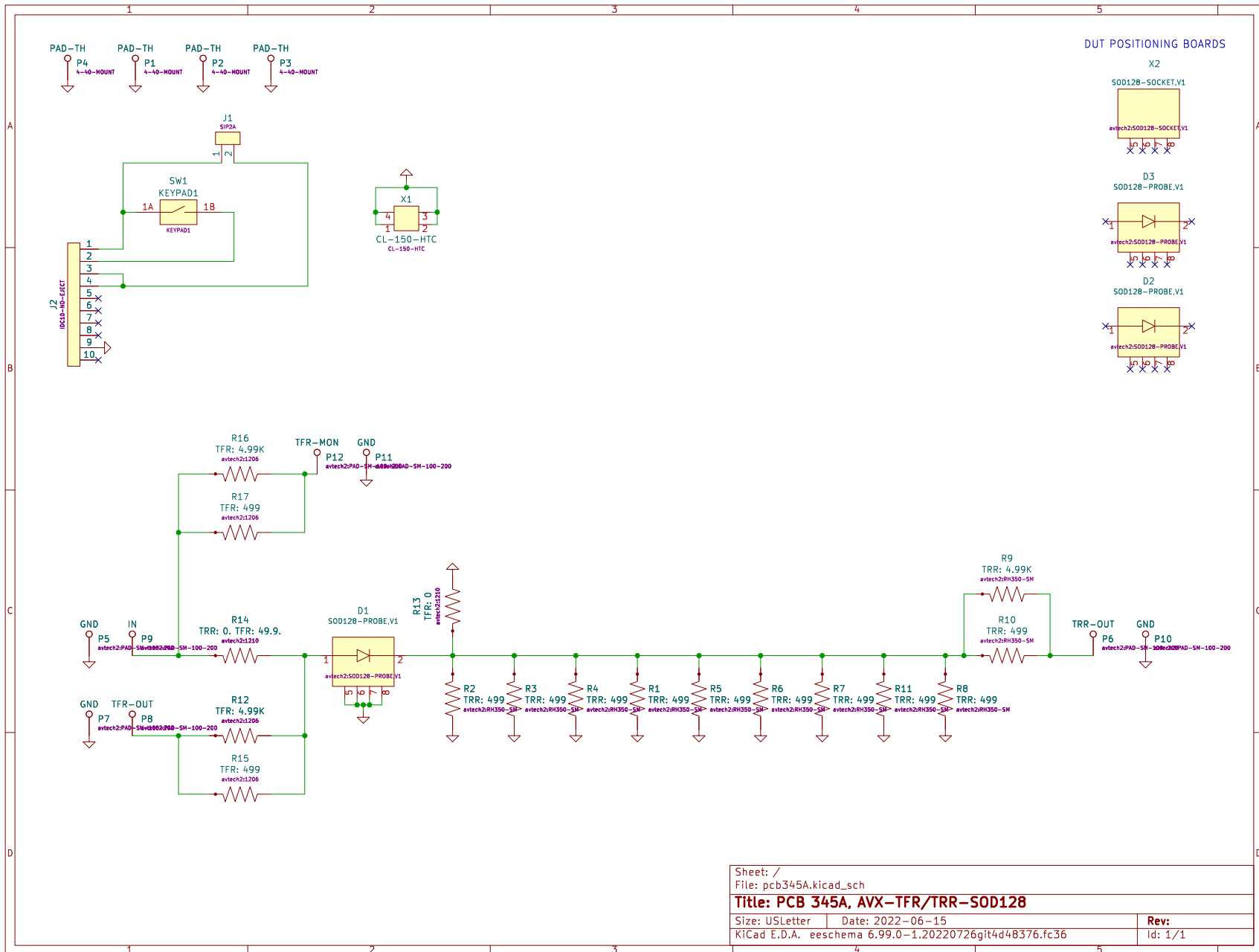

PERFORMANCE CHECK SHEET