



AVTECH ELECTROSYSTEMS LTD.

NANOSECOND WAVEFORM ELECTRONICS
SINCE 1975

P.O. BOX 265
OGDENSBURG, NY
U.S.A. 13669-0265

TEL: 888-670-8729 (USA & Canada) or +1-613-686-6675 (Intl)
FAX: 800-561-1970 (USA & Canada) or +1-613-686-6679 (Intl)

info@avtechpulse.com - <http://www.avtechpulse.com/>

BOX 5120, LCD MERIVALE
OTTAWA, ONTARIO
CANADA K2C 3H5

INSTRUCTIONS

MODEL AVX-S1-P1C

PLUG-IN SOCKET OUTPUT MODULE

SERIAL NUMBER: _____

“P1C” SOCKET VIEW

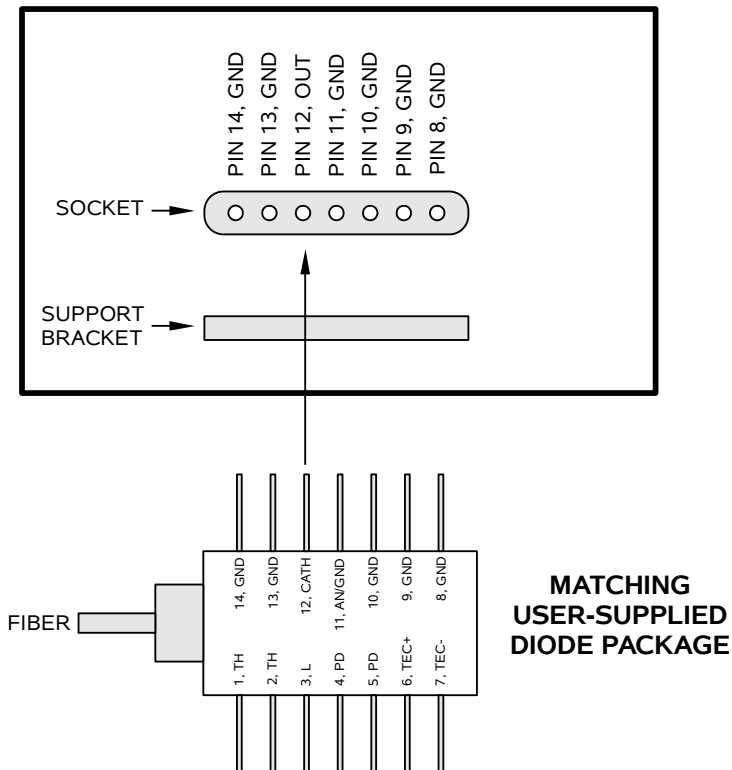

WARRANTY

Avtech Electrosystems Ltd. warrants products of its manufacture to be free from defects in material and workmanship under conditions of normal use. If, within one year after delivery to the original owner, and after prepaid return by the original owner, this Avtech product is found to be defective, Avtech shall at its option repair or replace said defective item. This warranty does not apply to units which have been disassembled, modified or subjected to conditions exceeding the applicable specifications or ratings. This warranty is the extent of the obligation assumed by Avtech with respect to this product and no other warranty or guarantee is either expressed or implied.

TECHNICAL SUPPORT

Phone: 888-670-8729 (USA & Canada) or +1-613-686-6675 (International)
Fax: 800-561-1970 (USA & Canada) or +1-613-686-6679 (International)

E-mail: info@avtechpulse.com
World Wide Web: <http://www.avtechpulse.com>

TABLE OF CONTENTS

WARRANTY.....	2
TECHNICAL SUPPORT.....	2
TABLE OF CONTENTS.....	3
INTRODUCTION.....	4
AVAILABLE OPTIONS.....	5
SPECIFICATIONS.....	6
GENERAL INFORMATION.....	7
INSTALLING THE DEVICE UNDER TEST.....	7
NORMAL TEST ARRANGEMENT.....	8
THERMAL CONTROL (-T1C UNITS).....	9
SIGNAL CONNECTORS ON THE OUTPUT MODULE.....	10
AMPLITUDE CONTROL.....	10
-INV OPTION.....	11
COMPATIBLE PULSE GENERATORS.....	11
PERFORMANCE CHECKSHEET.....	12

Manual Reference: /filesserver2/officefiles/instructword/avx-s/AVX-S1-P1C with -T1C-INV optional,ed5.odt.

Last modified November 12, 2013.

Copyright © 2013 Avtech Electrosystems Ltd, All Rights Reserved.

INTRODUCTION

The AVX-S series of bias insertion units is designed to combine a pulse signal with a DC bias, and supply the resulting signal to a laser diode, which is inserted into a high quality socket included on the mount. The bias insertion module includes the necessary networks to match the laser diode to the pulse source, as well as networks for applying DC bias to the diode.

The AVX-S1-P1C is specifically designed to accommodate butterfly-packaged laser diodes with the pinout illustrated below:

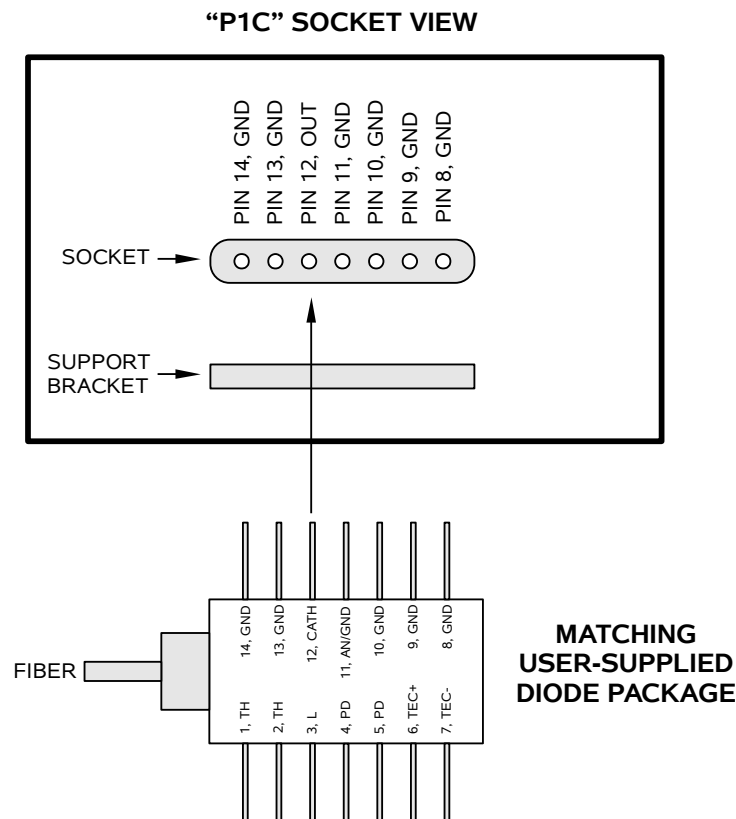

AVAILABLE OPTIONS

A number of options are available for the AVX-S1-P1C, including:

- T1C option: Adds a secondary (low-bandwidth) slide-on socket board for pins 1-7 of a butterfly package. A flexible cable connects the slide-on socket to the output module. A male DB-9 connector is provided on the output module, which provides access to the thermal control pins of the diode. DB-9 pin 2 connects to diode pin 1 (TH). DB-9 pin 3 connects to diode pin 2 (TH). DB-9 pin 4 connects to diode pin 6 (TEC+). DB-9 pin 5 connects to diode pin 7 (TEC-). The remaining DB-9 pins are unconnected. Pins 4 and 5 of the diode are grounded. Pin 3 is unconnected. Access to the photodiode, if present, is not provided. This option requires the -P1C option. This option is designed for compatibility with Thorlabs temperature controllers and certain QPhotonics laser diodes. It may be suitable for others as well.
- INV option: Adds a polarity-inverting transformer to the input of the AVX-S1-P1C.

SPECIFICATIONS

Model:	AVX-S1
Peak diode current:	400 mA
Max. input amplitude:	20 Volts
Pulse width:	0.4 ¹ - 200 ns
Rise time:	0.2 ns ¹
Pulse PRF range:	DC - 25 MHz
Max. bias current:	100 mA
Max. bias voltage:	50 Volts
Input impedance:	50 Ohms
N (transformer ratio ^{2,3}):	+1
$R_S + R_{DIODE}$:	50 Ohms
IN connector:	SMA female (one)
Other connectors:	MV, MI, MD: SMA (female), DC bias: solder terminal
Diode socket:	-P1B option:for specific butterfly package, see footnote ⁵
Dimensions:	H x W x D: 41 mm x 66 mm x 76 mm (1.6" x 2.6" x 3.0")
Material:	Cast aluminum, blue enamel

- 1) Lower pulse widths (to 0.2 ns) and faster rise times (0.1 ns) may be possible for laser diode packages with very low parasitic inductance. The -P0 and -P2 packages generally have very low inductance. The -P1, -P3, and -TO3 packages normally have somewhat higher parasitic inductance.
- 2) The transformer reduces the input voltage by a factor of N (approx) and increases the current by a factor of N (approx). The load resistance ($R_S + R_{DIODE}$) must equal $50\Omega / N^2$ (approx).
- 3) A polarity inverting option is available. Add the suffix -INV to the model number to specify this option. "N" is negative ($\approx -70\%$ of the standard value) when this option is installed.

GENERAL INFORMATION

INSTALLING THE DEVICE UNDER TEST

The AVX-S1-P1C has a “P1C” high-speed socket for pins 8-14 of the diode under test. If the “-T1C” option has been specified, a slide-on socket for pins 1-7 of the diode will also be present.

The “P1C” socket consists of seven high-bandwidth pin sockets. This socket arrangement will accept pins 8-14 of a standard butterfly package with 0.5 mm wide pins. A negative pulse will be applied to the diode cathode (pin 12). Pins 8-11 and 13-14 will be grounded. The laser input impedance (dV/dI at lasing) must be 25 Ohms (+/- 5 Ohms).

The optional “T1C” socket consists of a low-bandwidth slide-on socket board for pins 1-7 of a butterfly package. A flexible cable connects the slide-on socket to the output module. A male DB-9 connector is provided on the output module, which provides P1B access to the thermal control pins of the diode. DB-9 pin 2 connects to diode pin 1 (TH). DB-9 pin 3 connects to diode pin 2 (TH). DB-9 pin 4 connects to diode pin 6 (TEC+). DB-9 pin 5 connects to diode pin 7 (TEC-). The remaining DB-9 pins are unconnected. Pins 4 and 5 of the diode are grounded. Pin 3 is unconnected. Access to the photodiode, if present, is not provided. This option is designed for compatibility with Thorlabs temperature controllers and certain QPhotonics laser diodes. It may be suitable for others as well.

With no diode installed, the output module will look similar to this:

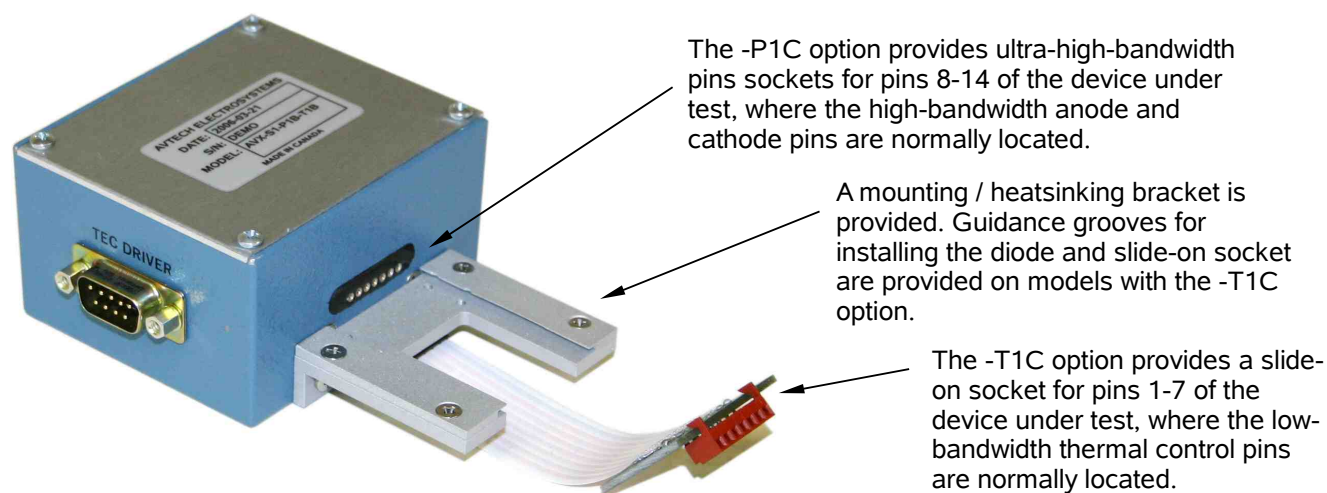

The diode is first installed by sliding pins 8-14 into the “P1C” pin sockets, as shown below:

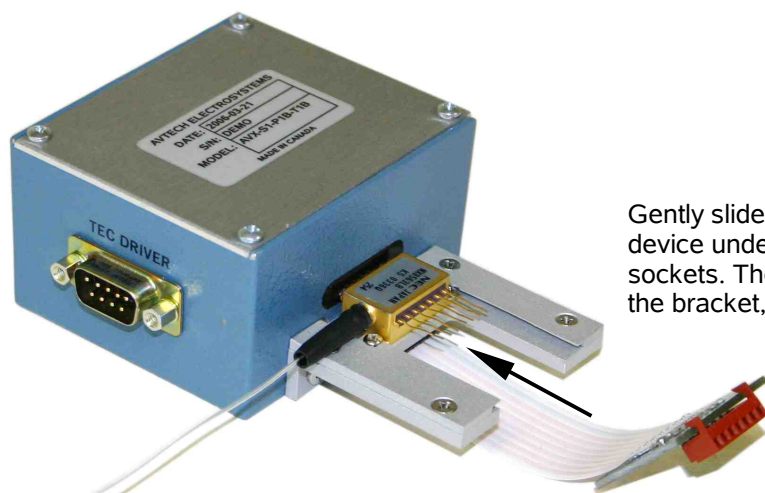

Gently slide the high-bandwidth side of the device under test into the matching pin sockets. The device can be screwed down to the bracket, if desired.

If present, the T1C slide-on socket assembly can then be slid onto pins 1-7, as shown below:

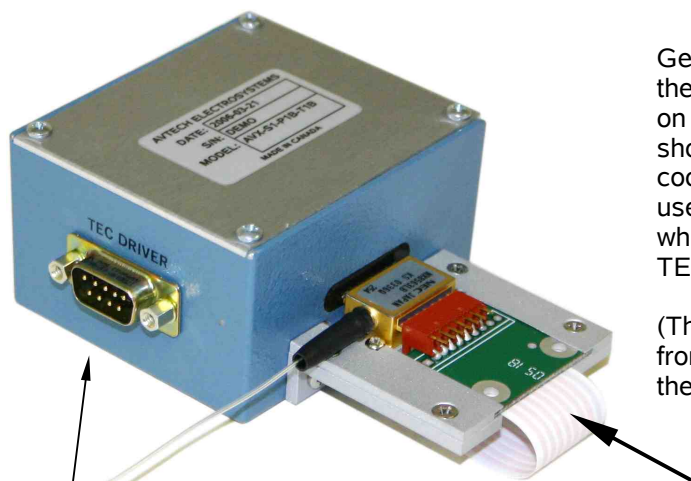

Gently slide the low-bandwidth slide-on socket onto the matching pins of the device under test. The slide-on socket is connected to the output module using a short length of flexible ribbon cable. The thermoelectric cooler and thermistor pins are made accessible to the user through the “TEC DRIVER” DB-9 connector, which will mate to cables from common third-party TEC controllers.

(The SMA connectors which connect to the cabling from the mainframe are on the module side opposite the pin socket. They are not visible in these photos.)

To optional third-party TEC controller.

NORMAL TEST ARRANGEMENT

To fully test the instrument, and for normal operation, the output module must be connected as shown below:

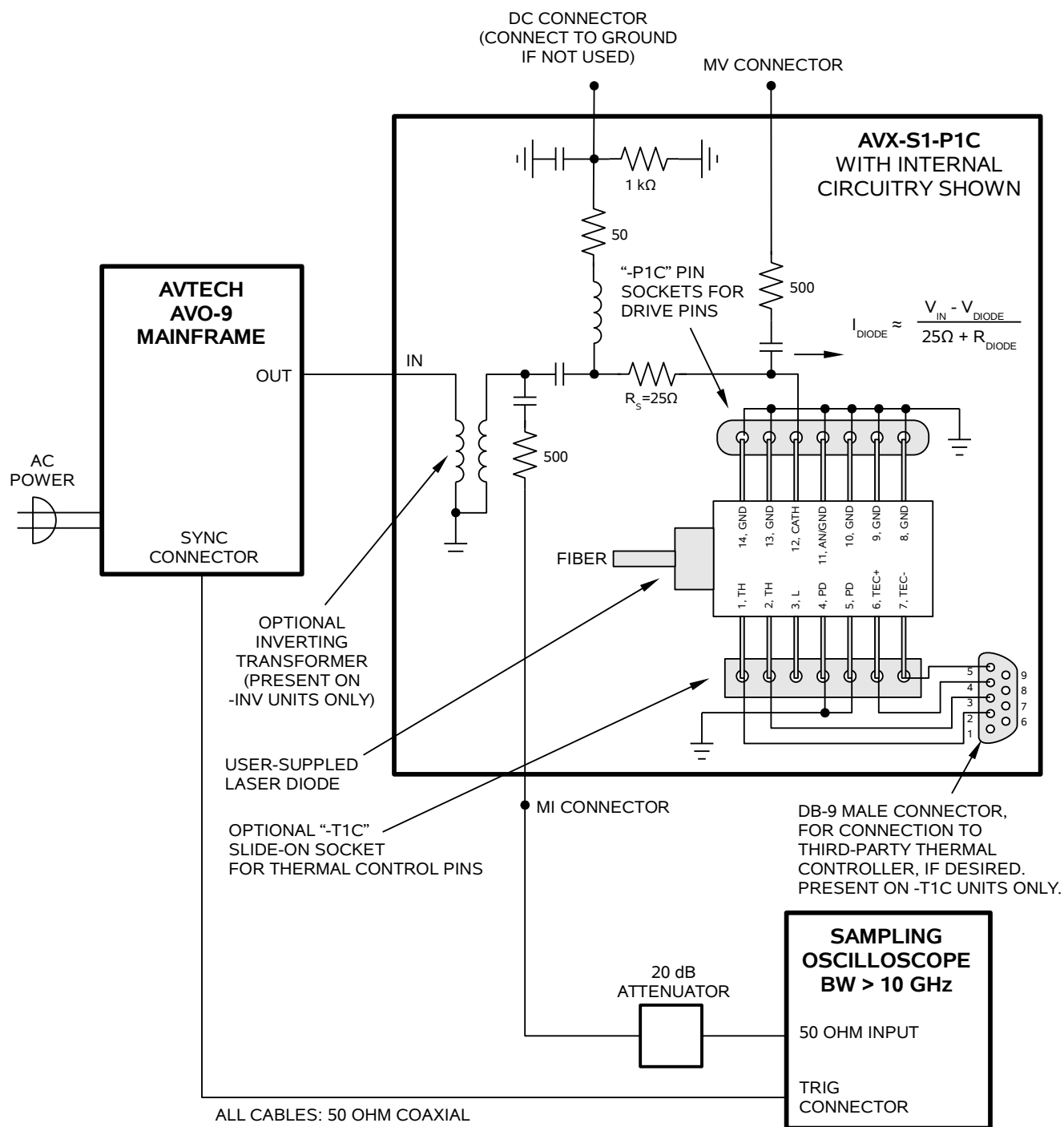

THERMAL CONTROL (-T1C UNITS)

Models with the “-T1C” option include a DB-9 male connector that will mate to third-party temperature controllers. These third-party controllers provide a means of controlling the thermoelectric cooler that is typically present in butterfly-packaged laser diodes, if desired. The need for cooling is dependent on the user's application. Cooling is generally recommended by device manufacturers.

SIGNAL CONNECTORS ON THE OUTPUT MODULE

An oscilloscope may be used to monitor the MI and MV outputs. A forward DC bias may be applied to the laser diode by connecting a DC potential of 0 to -10 Volts to the DC solder terminal. The application of a small forward bias often yields a more ideal diode current waveform (as observed on the MI port).

⚠ Note that the DC port must be shorted to ground if a bias is not applied. Waveform distortions will occur otherwise.

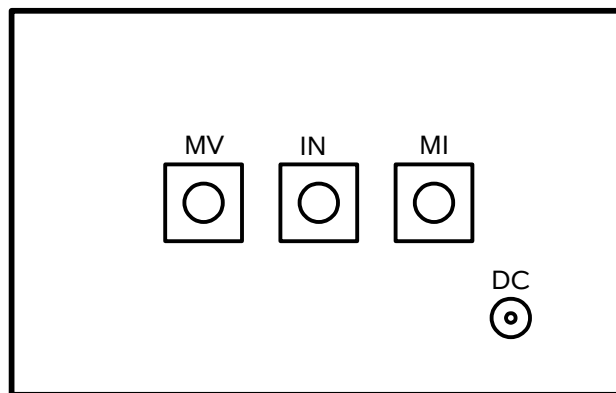

AVX-S1-P1B OUTPUT MODULE, CONNECTOR VIEW

AMPLITUDE CONTROL

When using the AVX-S1-P1C with an Avtech AVO-9 series pulse generator, the pulse current through the diode load is given by:

$$I_{\text{DIODE}} = (V_{\text{SET}} - V_{\text{DIODE}}) / (25\Omega + R_{\text{DIODE}})$$

where V_{SET} is the (normally negative) amplitude setting on the pulser, V_{DIODE} is the forward voltage drop across the diode (up to -3V), and R_{DIODE} is the resistor internal to the laser diode (typically 20Ω to 30Ω). The 25Ω resistance is built into the AVX-S1-P1C output module.

For optimal results, the laser diode resistance should be 25Ω, so that $25\Omega + R_{\text{DIODE}} = 50\Omega$, resulting in a proper transmission line match for the 50Ω coaxial cabling. However, laser diode resistances in the range of 20Ω to 30Ω will provide good results with minimal distortion.

Note that the anode is grounded, so a negative voltage pulse is normally required (to drive the cathode).

-INV OPTION

Models with the -INV option have a polarity inverting transformer on the input. This is useful if the user has a pulse generator that generates positive amplitudes only. (The standard AVX-S1-P1C requires a negative pulse for normal operation.)

The amplitude control equation becomes:

$$I_{\text{DIODE}} \approx (-V_{\text{SET}} - V_{\text{DIODE}}) / (25\Omega + R_{\text{DIODE}})$$

In practice, there may be some loss (as much as ~30%) in the inverting transformer, so the actual current output may be somewhat lower.

COMPATIBLE PULSE GENERATORS

The AVX-S1-P1C is designed for use with high-speed Avtech pulse generators, such as those in the AVP, AVPP, AVMP, AVMM, AVMR, AVN, and other families. The AVX-S1-P1C may also be suitable for use with other pulse generators. Contact Avtech (info@avtechpulse.com) if you need assistance selecting a pulse generator.

Models in the Avtech AVO-9 series include a pulse generator and an AVX-S series output module in a complete “bundle”. See <http://www.avtechpulse.com/laser/> for details.

PERFORMANCE CHECKSHEET