



AVTECH ELECTROSYSTEMS LTD.

NANOSECOND WAVEFORM ELECTRONICS  
SINCE 1975

info@avtechpulse.com  
http://www.avtechpulse.com/

Tel: 888-670-8729 (USA & Canada)  
or +1-613-686-6675 (Worldwide)

BOX 5120, LCD MERIVALE  
OTTAWA, CANADA K2C3H5

## INSTRUCTIONS

MODEL AVX-S5-P1C

PLUG-IN SOCKET OUTPUT MODULE

SERIAL NUMBER: 14221, 14222

### "P1C" SOCKET VIEW

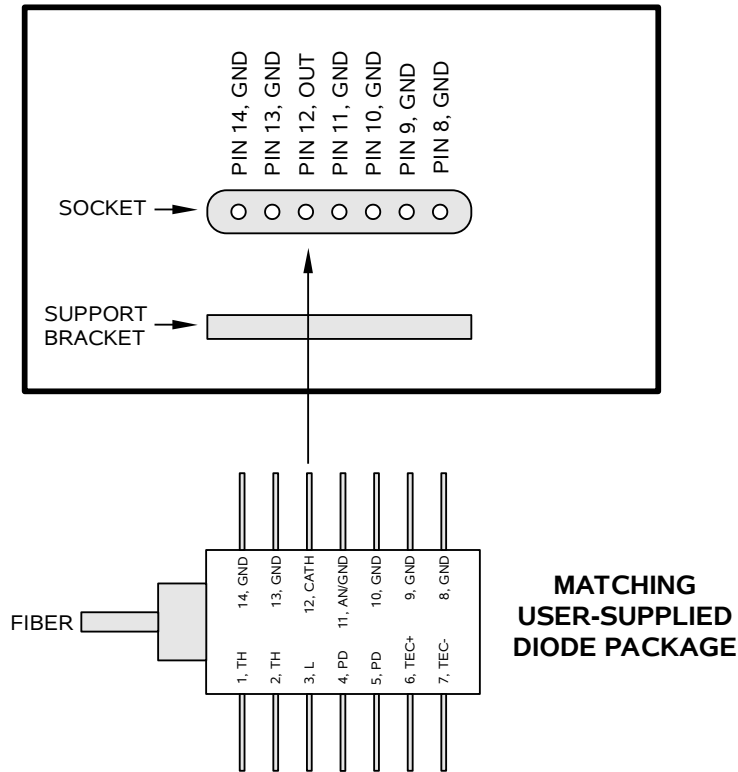

### WARRANTY

Avtech Electrosystems Ltd. warrants products of its manufacture to be free from defects in material and workmanship under conditions of normal use. If, within one year after delivery to the original owner, and after prepaid return by the original owner, this Avtech product is found to be defective, Avtech shall at its option repair or replace said defective item. This warranty does not apply to units which have been disassembled, modified or subjected to conditions exceeding the applicable specifications or ratings. This warranty is the extent of the obligation assumed by Avtech with respect to this product and no other warranty or guarantee is either expressed or implied.

### TECHNICAL SUPPORT

Phone: 888-670-8729 (USA & Canada)  
or +1-613-686-6675 (Worldwide)

E-mail: [info@avtechpulse.com](mailto:info@avtechpulse.com)  
World Wide Web: <http://www.avtechpulse.com>

## TABLE OF CONTENTS

<b>WARRANTY</b> .....	<b>2</b>
<b>TECHNICAL SUPPORT</b> .....	<b>2</b>
<b>TABLE OF CONTENTS</b> .....	<b>3</b>
<b>INTRODUCTION</b> .....	<b>4</b>
<b>AVAILABLE OPTIONS</b> .....	<b>5</b>
<b>SPECIFICATIONS</b> .....	<b>6</b>
<b>GENERAL INFORMATION</b> .....	<b>7</b>
<b>INSTALLING THE DEVICE UNDER TEST</b> .....	<b>7</b>
<b>NORMAL TEST ARRANGEMENT</b> .....	<b>8</b>
<b>THERMAL CONTROL (-T1C UNITS)</b> .....	<b>9</b>
<b>SIGNAL CONNECTORS ON THE OUTPUT MODULE</b> .....	<b>10</b>
<b>AMPLITUDE CONTROL</b> .....	<b>10</b>
<b>PERFORMANCE CHECKSHEET</b> .....	<b>11</b>

Manual Reference: /filesserver2/officefiles/instructword/avx-s/AVX-S5-P1C,ed1.odt.

Last modified March 9, 2022.

Copyright © 2022 Avtech Electrosystems Ltd, All Rights Reserved.

## INTRODUCTION

AVX-S plug-in output modules couple a pulse signal to a laser diode, which is inserted into a high quality socket included on the module. The module includes the necessary networks to match the laser diode to the pulse source.

The AVX-S5-P1C is specifically designed to accommodate butterfly-packaged laser diodes with the pinout illustrated below:

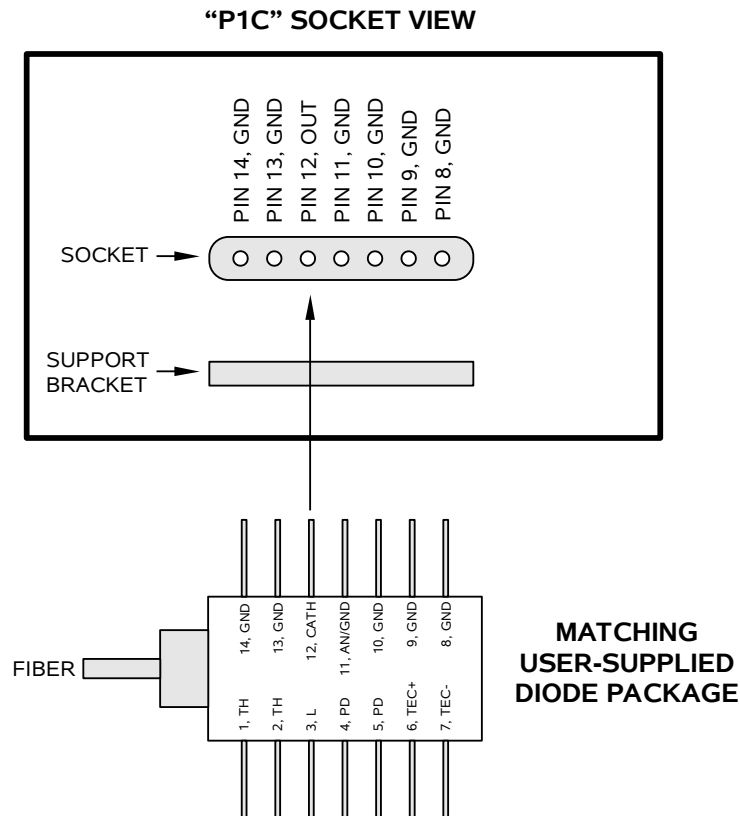

### AVAILABLE OPTIONS

-T1C option: Adds a secondary (low-bandwidth) slide-on socket board for pins 1-7 of a butterfly package. A flexible cable connects the slide-on socket to the output module. A male DB-9 connector is provided on the output module, which provides access to the thermal control pins of the diode. DB-9 pin 2 connects to diode pin 1 (TH). DB-9 pin 3 connects to diode pin 2 (TH). DB-9 pin 4 connects to diode pin 6 (TEC+). DB-9 pin 5 connects to diode pin 7 (TEC-). The remaining DB-9 pins are unconnected. Pins 4 and 5 of the diode are grounded. Pin 3 is unconnected. Access to the photodiode, if present, is not provided. This option requires the -P1C option. This option is designed for compatibility with Thorlabs temperature controllers and certain QPhotonics laser diodes. It may be suitable for others as well.

## SPECIFICATIONS

Model:	AVX-S5
Peak diode current ( $I_{PEAK}$ ):	2 Amps
Max. input amplitude:	100 Volts
Pulse width (PW):	10 ns - 10 ms
Rise time (20%-80%):	1 ns
Pulse repetition freq. (PRF) <sup>1</sup> :	DC – 1 MHz
Pulse input impedance:	50 $\Omega$
$R_s$ <sup>2</sup> :	25 $\Omega$ , 5 W
IN connector:	1 SMA
Included cables <sup>2</sup> :	One 60 cm / 2 ft, SMA male to BNC male
Other connectors:	MV, MI: SMA (female)
Diode socket:	<p>-P1C option: The socket will accept pins 8-14 of a standard butterfly package with 0.5 mm wide pins. A negative pulse will be applied to the diode cathode (pin 12). Pins 8-11 and 13-14 will be grounded. Four mounting holes on a 8.9 x 26 mm grid will be provided. The laser input impedance (dV/dI at lasing) must be 25 <math>\Omega</math> (+/- 5 <math>\Omega</math>).</p> <p>A low-bandwidth slide-on socket can also be provided for pins 1-7 of the diode, with the thermal control pins brought out to a standard DB-9 connector (-T1C option)</p>
Dimensions:	H x W x D: 42 mm x 67 mm x 76 mm (1.6" x 2.6" x 3.0")
Material:	Cast aluminum, blue enamel

- 1) These devices are generally intended for use with Avtech pulse generators (in pulse mode), and are not characterized for CW operation. An estimate of the upper bandwidth limit may be made from the rated rise time. The lower end of the CW passband may be estimated using the maximum rated pulse width.
- 2) Do not exceed the rated power dissipation. For pulse mode operation, the power dissipated in  $R_s$  is given by  $(I_{PULSE}^2 \times R_s \times PW \times PRF)$ .

## GENERAL INFORMATION

### INSTALLING THE DEVICE UNDER TEST

The AVX-S5-P1C has a “P1C” high-speed socket for pins 8-14 of the diode under test. If the “-T1C” option has been specified, a slide-on socket for pins 1-7 of the diode will also be present.

The “P1C” socket consists of seven high-bandwidth pin sockets. This socket arrangement will accept pins 8-14 of a standard butterfly package with 0.5 mm wide pins. A negative pulse will be applied to the diode cathode (pin 12). Pins 8-11 and 13-14 will be grounded. The laser input impedance (dV/dI at lasing) must be 25 Ohms (+/- 5 Ohms).

The optional “T1C” socket consists of a low-bandwidth slide-on socket board for pins 1-7 of a butterfly package. A flexible cable connects the slide-on socket to the output module. A male DB-9 connector is provided on the output module, which provides P1B access to the thermal control pins of the diode. DB-9 pin 2 connects to diode pin 1 (TH). DB-9 pin 3 connects to diode pin 2 (TH). DB-9 pin 4 connects to diode pin 6 (TEC+). DB-9 pin 5 connects to diode pin 7 (TEC-). The remaining DB-9 pins are unconnected. Pins 4 and 5 of the diode are grounded. Pin 3 is unconnected. Access to the photodiode, if present, is not provided. This option is designed for compatibility with Thorlabs temperature controllers and certain QPhotonics laser diodes. It may be suitable for others as well.

With no diode installed, the output module will look similar to this:

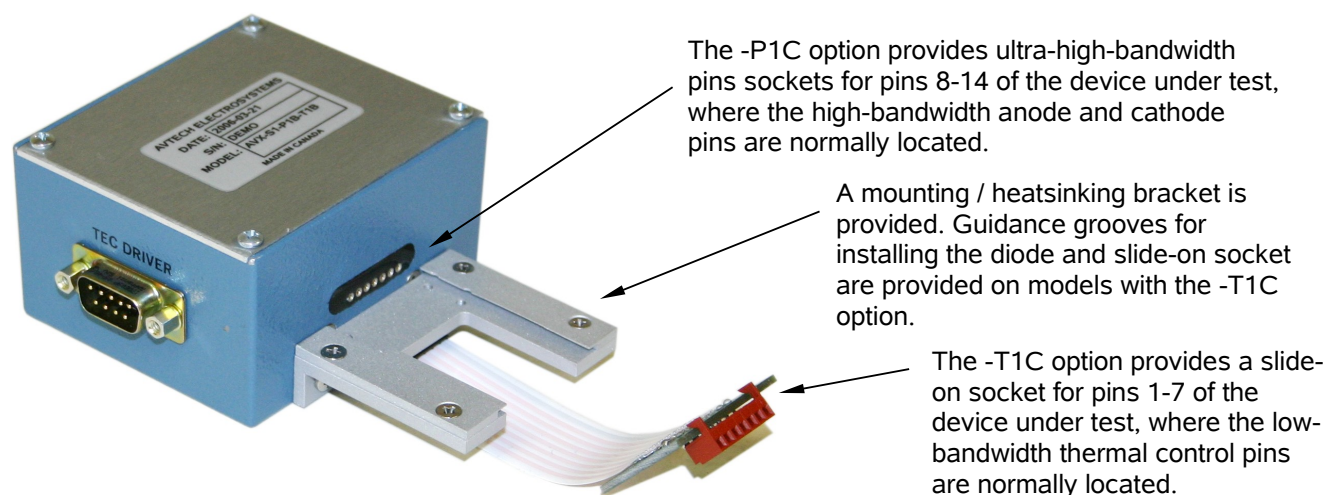

The diode is first installed by sliding pins 8-14 into the “P1C” pin sockets, as shown below:

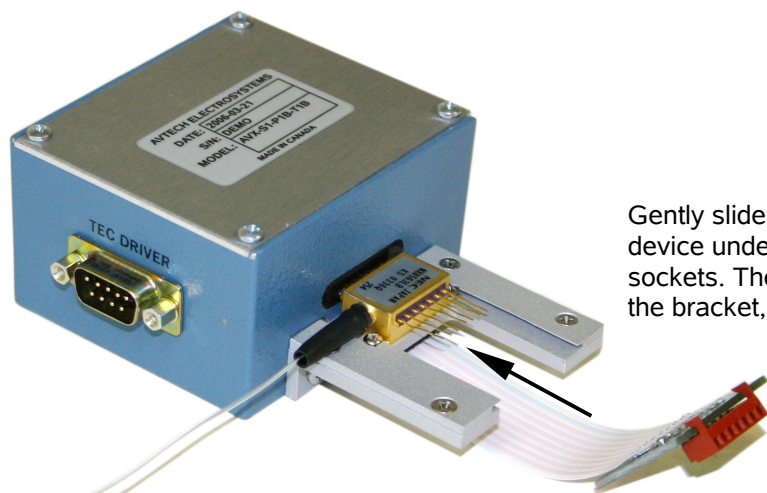

Gently slide the high-bandwidth side of the device under test into the matching pin sockets. The device can be screwed down to the bracket, if desired.

If present, the T1C slide-on socket assembly can then be slid onto pins 1-7, as shown below:

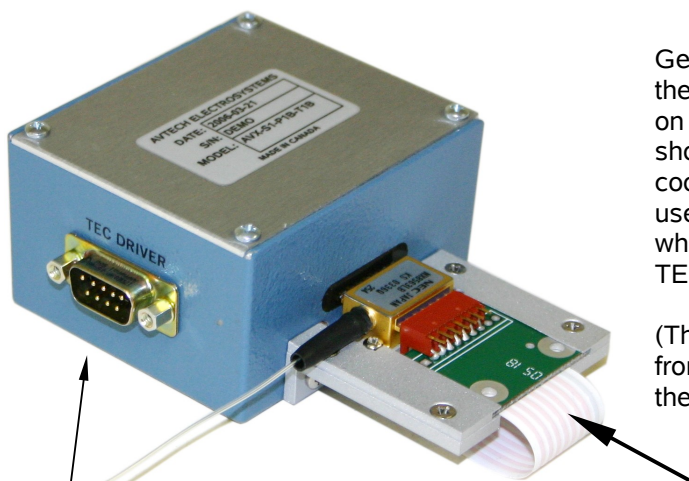

Gently slide the low-bandwidth slide-on socket onto the matching pins of the device under test. The slide-on socket is connected to the output module using a short length of flexible ribbon cable. The thermoelectric cooler and thermistor pins are made accessible to the user through the “TEC DRIVER” DB-9 connector, which will mate to cables from common third-party TEC controllers.

(The SMA connectors which connect to the cabling from the mainframe are on the module side opposite the pin socket. They are not visible in these photos.)

To optional third-party TEC controller.

## NORMAL TEST ARRANGEMENT

To fully test the instrument, and for normal operation, the output module must be connected as shown below:



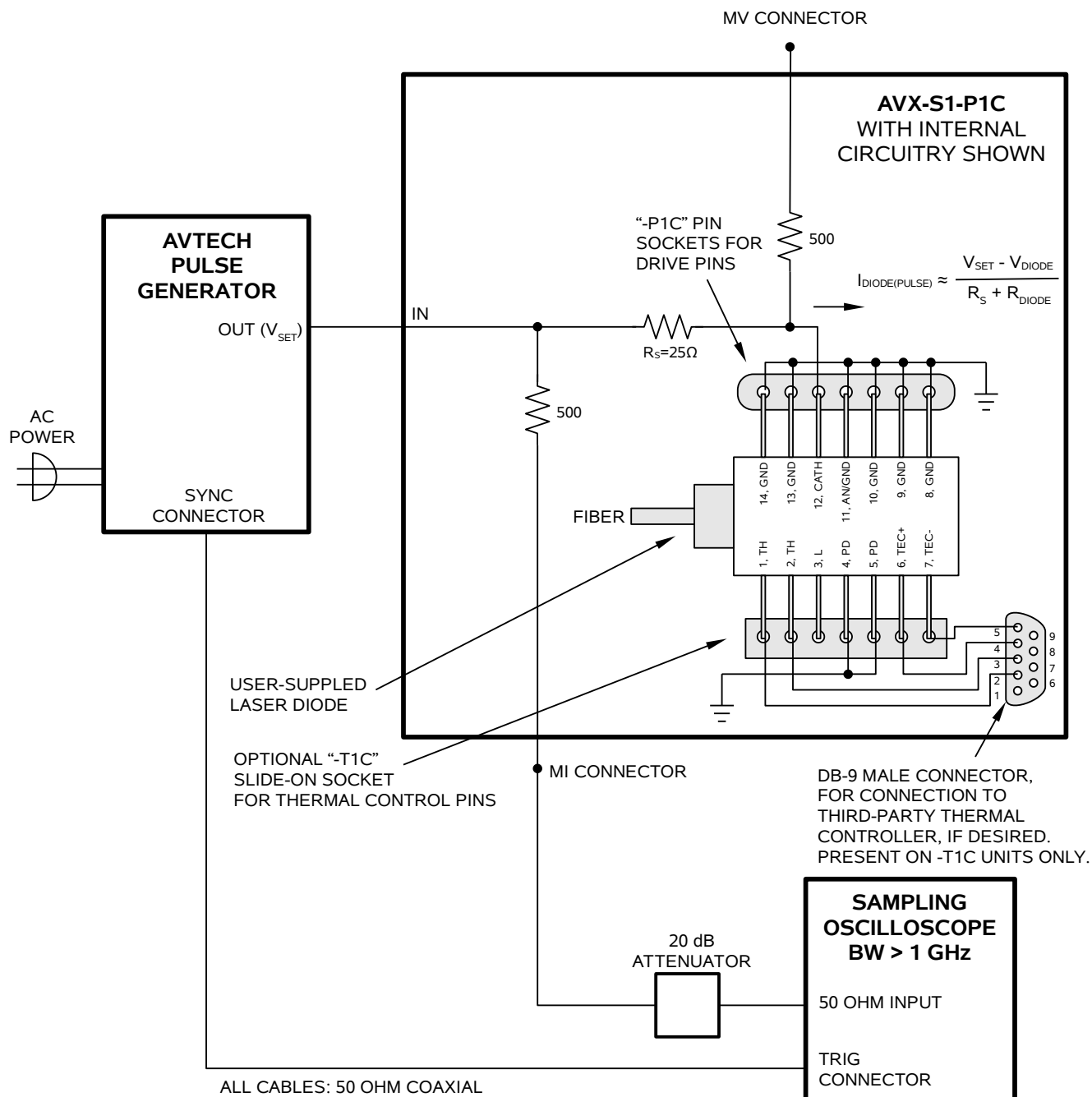

### THERMAL CONTROL (-T1C UNITS)

Models with the “-T1C” option include a DB-9 male connector that will mate to third-party temperature controllers. These third-party controller provide a means of controlling the thermoelectric cooler that is typically present in butterfly-packaged laser diodes, if desired. The need for cooling is dependent on the user's application. Cooling is generally recommended by device manufacturers.

## SIGNAL CONNECTORS ON THE OUTPUT MODULE

An oscilloscope may be used to monitor the MI and MV outputs.

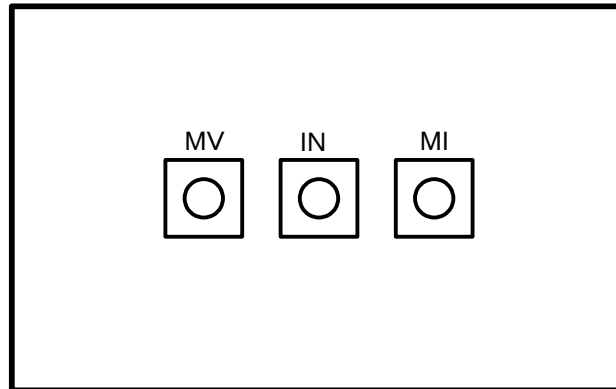

## AMPLITUDE CONTROL

When using the AVX-S5-P1C with an Avtech AVO-9 series pulse generator, the pulse current through the diode load is given by:

$$I_{\text{DIODE}} = (V_{\text{SET}} - V_{\text{DIODE}}) / (25\Omega + R_{\text{DIODE}})$$

where  $V_{\text{SET}}$  is the (normally negative) amplitude setting on the pulser,  $V_{\text{DIODE}}$  is the forward voltage drop across the diode (up to -3V), and  $R_{\text{DIODE}}$  is the resistor internal to the laser diode (typically 20Ω to 30Ω). The 25Ω resistance is built into the AVX-S5-P1C output module.

For optimal results, the laser diode resistance should be 25Ω, so that  $25\Omega + R_{\text{DIODE}} = 50\Omega$ , resulting in a proper transmission line match for the 50Ω coaxial cabling. However, laser diode resistances in the range of 20Ω to 30Ω will provide good results with minimal distortion.

Note that the anode pin is grounded, so a negative voltage pulse is normally required (to drive the cathode).

PERFORMANCE CHECKSHEET